

Input data

Refrigerant	R449A	
Reference temperature	Dew point temperature	
Calculation mode	Refrigeration / Air Cond.	
Operating mode	Subcritical	
Power supply	400/3/50	
Condensing temperature	°C	45
Condensing pressure	bar	18.86
Liquid subcooling	K	2
Liquid temperature	°C	38.72
Evaporating temperature	°C	-5
Evaporating pressure	bar	4.33
Suction gas temperature	°C	20
Evaporator superheating	K	5

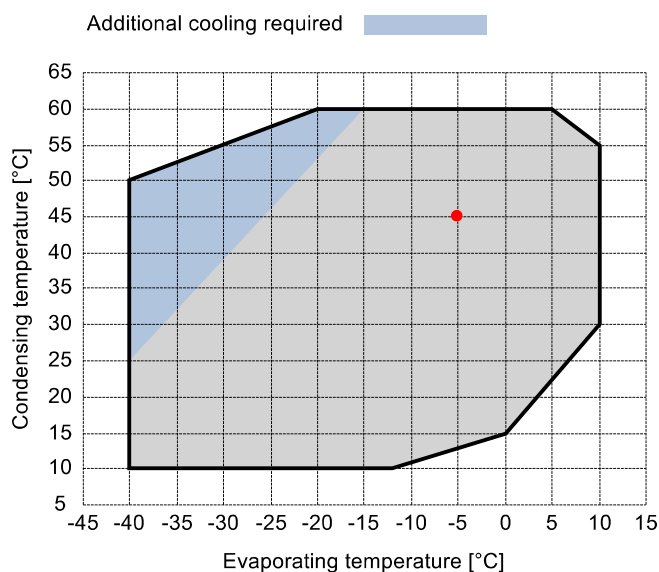

Output data

Compressor :		W60-187Y
Number of compressors :		FSx1
Refrigerating capacity	kW	115.159
Refrigerating capacity [*ref]	kW	112.746
Evaporator capacity	kW	101.996
Power input	W	40479
Condenser capacity, theor.	kW	155.638
Current	A	74.62
COP/EER	W/W	2.52
Mass flow	kg/h	2580
Operating frequency	Hz	50
Connection	-	PWS
Operating mode	-	100%
Discharge temperature	°C	96.2
Ratio (%)	%	100.0%
Note	-	
Oil flow	l/min	-
Heat Exchanged (oil Cooler)	kW	-
Oil Temp. at Oil Cooler Outlet	°C	-
Certified by	-	Frascold

Certified by:

- Frascold tentative data

Legend:

- *ref: At conditions according to EN12900
- Suction gas temperature = 20 °C
- Liquid subcooling = 0 K

P&I Diagram:

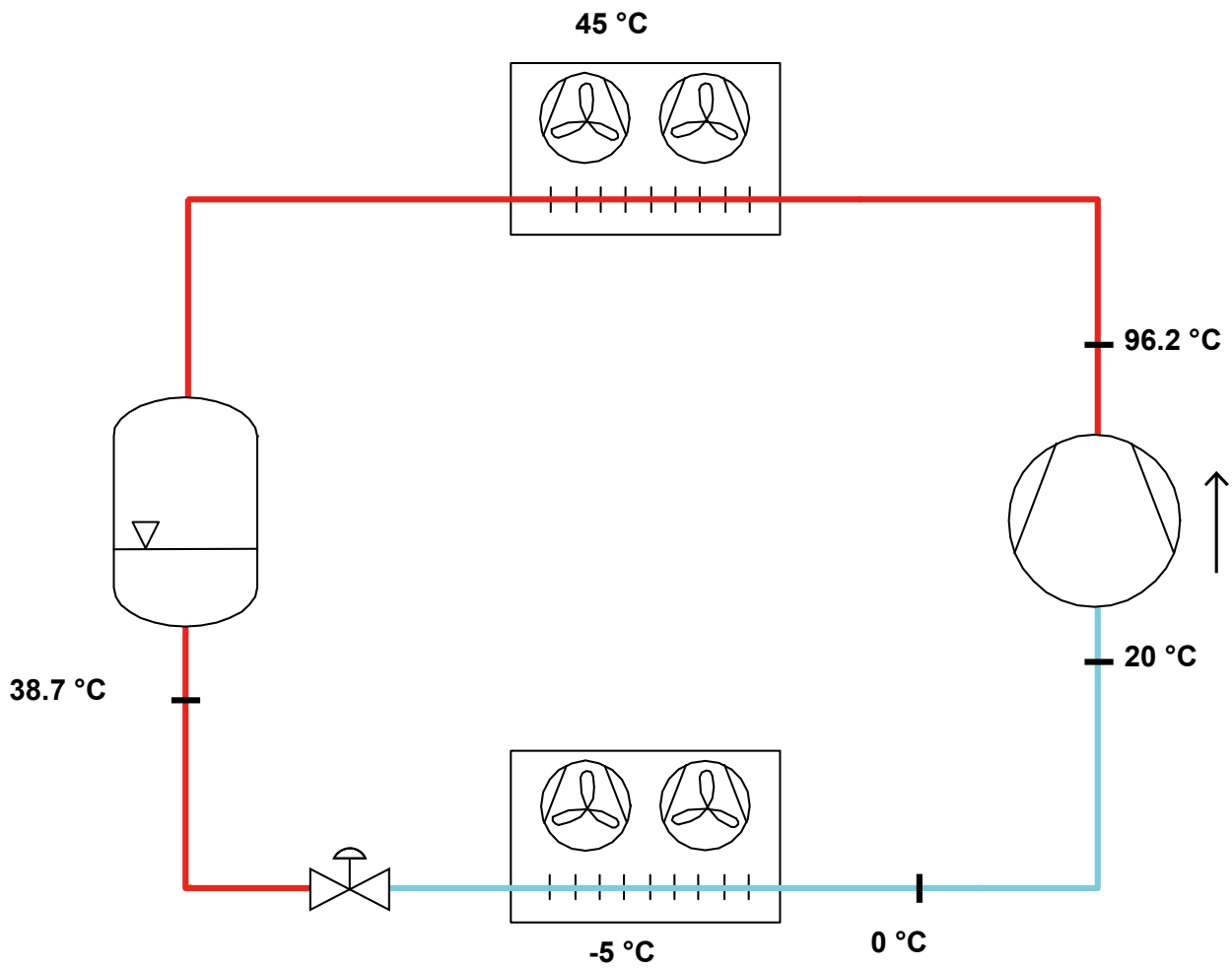

All data subject to change without notice

Model: W60-187Y

Refrigerant: R449A

Power supply: 400/3/50 PWS

Technical data:

Displacement	186.1 m³/h
Nominal compressor speed	1450 rpm
Motor voltage	400 V
Nominal operating frequency	50 Hz
Maximum allowed operating current (MRA)	103.5 A
Locked rotor current (LRA)	326 A
Locked rotor current (LRA), DOL	455 A
Number of pistons	8
Net weight	315 kg
Lubricant	FRASCOLD POE68
Oil charge	7.7 l
Maximum static pressure LP	20.5 bar
Maximum operating pressure HP	30 bar

Sound level:

Sound power level 5/50°C R404A @50Hz	86.5 dB(A)
Sound pressure (*) - Distance: 1 m	78.5 dB(A)
Sound power level -10/45°C R404A @50Hz	88.5 dB(A)
Sound pressure (*) - Distance: 1 m	80.5 dB(A)

*half sphere model

Motor connections:

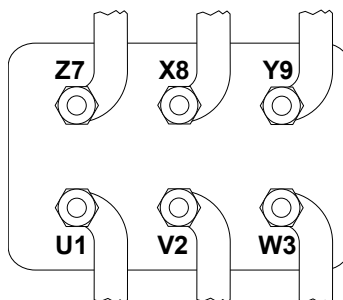

All data subject to change without notice

Model: W60-187Y

Refrigerant: R449A

Power supply: 400/3/50 PWS

Dimensions:

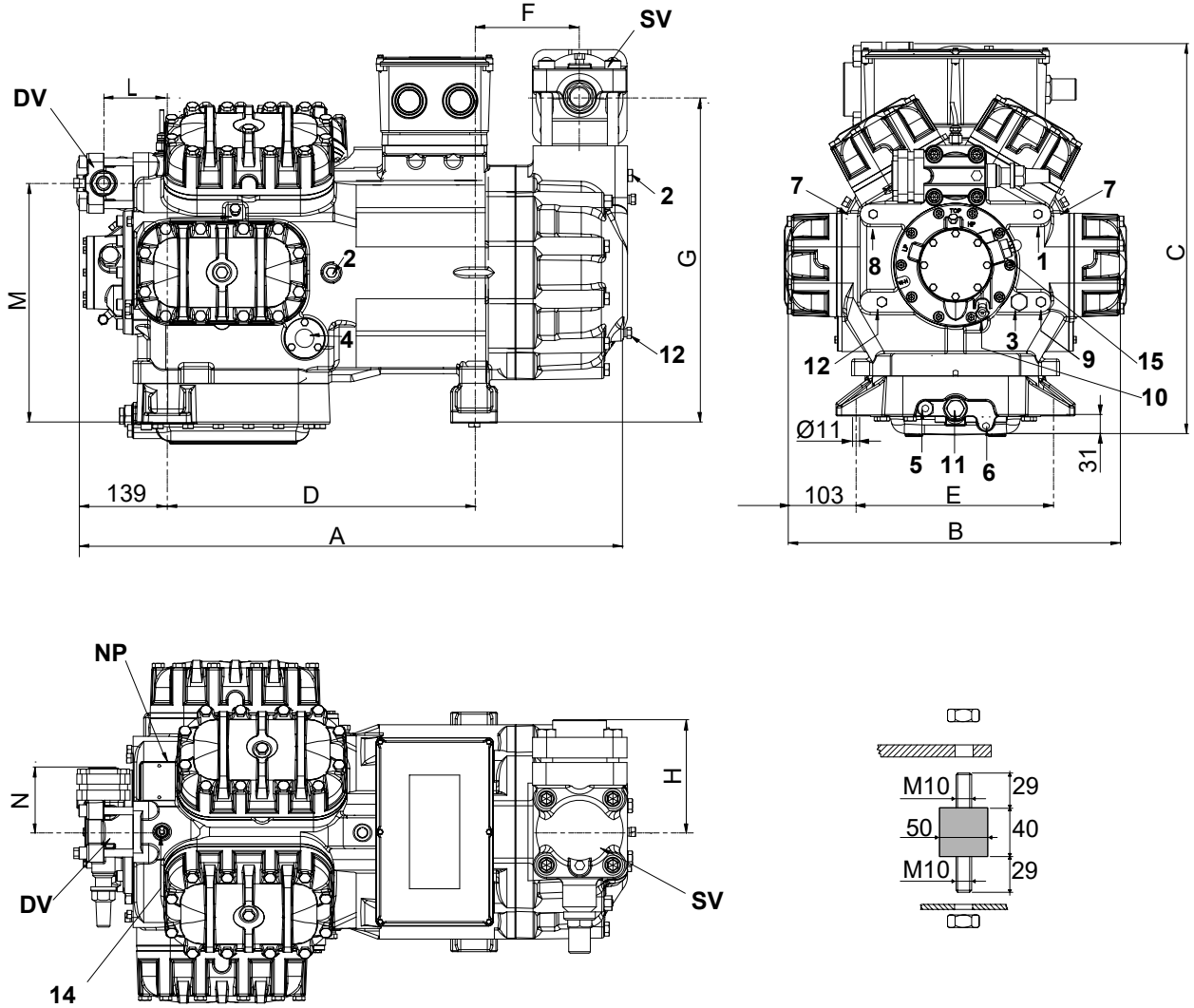

Legend:

SV: Suction Valve	3 1/8" in - 80 mm	2: Low pressure connection	1/4" NPT
DV: Discharge valve	1 5/8" in - 42 mm	3: Oil charge plug	3/8" GAS
A: Length	838 mm	4: Oil level sight glass	-
B: Width	511 mm	5: Crankcase heater seat	-
C: Height	588 mm	6: Oil drain plug	1/4" GAS
D: Base mounting	458 mm	7: Liquid injection plug	1/4" NPT
E: Base mounting	305 mm	8: Liquid injection sensor plug	1/8" NPT
F: Suction Valve	158 mm	9: Oil pressure switch connection (LP)	1/4" NPT
G: Suction Valve	486 mm	10: Oil pressure switch connection (HP)	1/4" SAE
H: Suction Valve	160 mm	11: Oil filter	3/8" GAS
L: Discharge valve	95 mm	12: Oil return plug	1/4" NPT
M: Discharge valve	358 mm	14: Max discharge temperature sensor connection	1/8" NPT
N: Discharge valve	95 mm	15: Electronic oil pressure switch connection	-
1: High pressure connection	1/8" NPT	NP: Nameplate	-

All data subject to change without notice

Model: W60-187Y

Refrigerant: R449A

Power supply: 400/3/50 PWS

Polynomial coefficients according to EN12900 for W60-187Y:

*S = T_{evap} ; D = T_{cond}

Reference conditions

Refrigerant	R449A
Ambient temperature	35 °C
Suction gas temperature	20 °C
Liquid subcooling	0 K
Frequency	50 Hz

	Refrigerating capacity [W]	Power input [W]
C1	2.332280E+005	8.364490E+003
C2	8.893120E+003	-6.629740E+002
C3	-2.027700E+003	1.172510E+003
C4	1.217660E+002	-1.859250E+001
C5	-8.041840E+001	3.294470E+001
C6	-2.491580E+000	-1.149920E+001
C7	5.490500E-001	-1.285680E-001
C8	-9.874310E-001	2.146610E-001
C9	5.576240E-003	-1.373330E-001
C10	4.094060E-003	6.092530E-002

$$Y = C1 + C2*S + C3*D + C4*S^2 + C5*S*D + C6*D^2 + C7*S^3 + C8*D*S^2 + C9*S*D^2 + C10*D^3$$