



# HTK95AA

## PRODUCT SPECIFICATION

### OPERATION:

Application:	L.B.P.	Max. Ambient Temp:	43°C
Refrigerant:	R600a	(1) Max. Steady Discharge Temp:	120°C
Operation:	Capillary	(1,2) Max. Peak Discharge Temp:	135°C
Cooling:	Static	Max. Steady Condensing Temp:	60°C
		(2) Max. Peak Condensing Temp:	70°C
		Max. Winding Temp:	130°C
		Max. Impurities:	30 mg
		Max.Total Compressor Water Content:	100 mg

### COMPRESSOR:

Displacement:	9.62 cc	Oil Type:	Mineral
Bore:	25.40 mm	(4) Viscosity:	10 cSt
Stroke:	19.00 mm	Suction Muffler:	Semi-direct

(3) Net Wt:	9.0 kg
Case Size:	h = 165.5 mm
Oil Charge:	180 cc

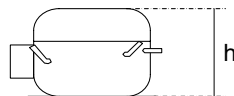

### ELECTRICAL:

Power Supply:	220 - 240V	Motor Type:	RSCR
Voltage Limits:	187 - 264V	Locked Rotor Current:	9.17 / 4.33 A**
Frequency:	50 Hz		
Phase:	1 ph		

Main Winding Resistance at 25°C:	20.9 Ω
Start Winding Resistance at 25°C:	15.9 Ω

\*\* Maximum current / Measured after 4 seconds

- (1) Measured 5cm. from the shell with insulated thermocouples
- (2) For transient conditions during 'Pull Down'
- (3) Net weight is with oil but without electrics
- (4) Measured at 40°C

For rated performance,

the suction line must be connected to the stub marked 'AS' on the attached drawing.

A run capacitor must be used with RSCR and CSR compressors.



# HTK95AA

## PRODUCT SPECIFICATION

### ELECTRICAL COMPONENTS:

ECC Starting Device: K 100-xx  
(1) ZEM Starting Device: PTC- 7100D5 / 8100  
ZEM PTC Resistance: 14 Ω  
'Combo' PTC Resistance: 14 Ω  
Run Capacitor: 4.0 μF

-xx Protector short code

### PROTECTORS:

PROTECTORS	BDG ¾	Combo	Electrica ¾	Texas ¾	Texas 4TM
Type	<b>AE 18 FU x</b>	<b>C2-222 NFBYY xx</b>	<b>T 0366 / kk</b>	<b>MRA 38057 xxxx</b>	<b>4TM 222 NFBYY xx</b>
Open °C	115 - 125 °C	115 - 125 °C	115 - 125 °C	115 - 125 °C	115 - 125 °C
Close °C	71 - 53 °C	70 - 52 °C	70 - 55 °C	70 - 52 °C	70 - 52 °C
U.T.C	1.90 A 70 °C	1.62 A 70 °C	1.31 A 90 °C	1.75 A 70 °C	1.62 A 70 °C
Time Check Current	6.35 A	6.7 A (5-15s)	6.80 A	6.35 A	6.7 A (5-15s)
Max. Current	15.0 A	15.0 A (2s max.)	13.0 A	12.8 A	15.0 A (2s max.)
Code (if any)	F5	27	CA	V4	

Alt. protectors: AF 18 FU x  
D5

*PTC-71.. / 81.. and Combo are for Terminal Cover version only.*

*(1) BDG protector AF type is for use with PTC-71.. only, and PTC-71.. is only fitted with BDG protector.*



# HTK95AA

## PRODUCT SPECIFICATION

### PERFORMANCE: (Graphs are at ASHRAE conditions)

220V 50Hz

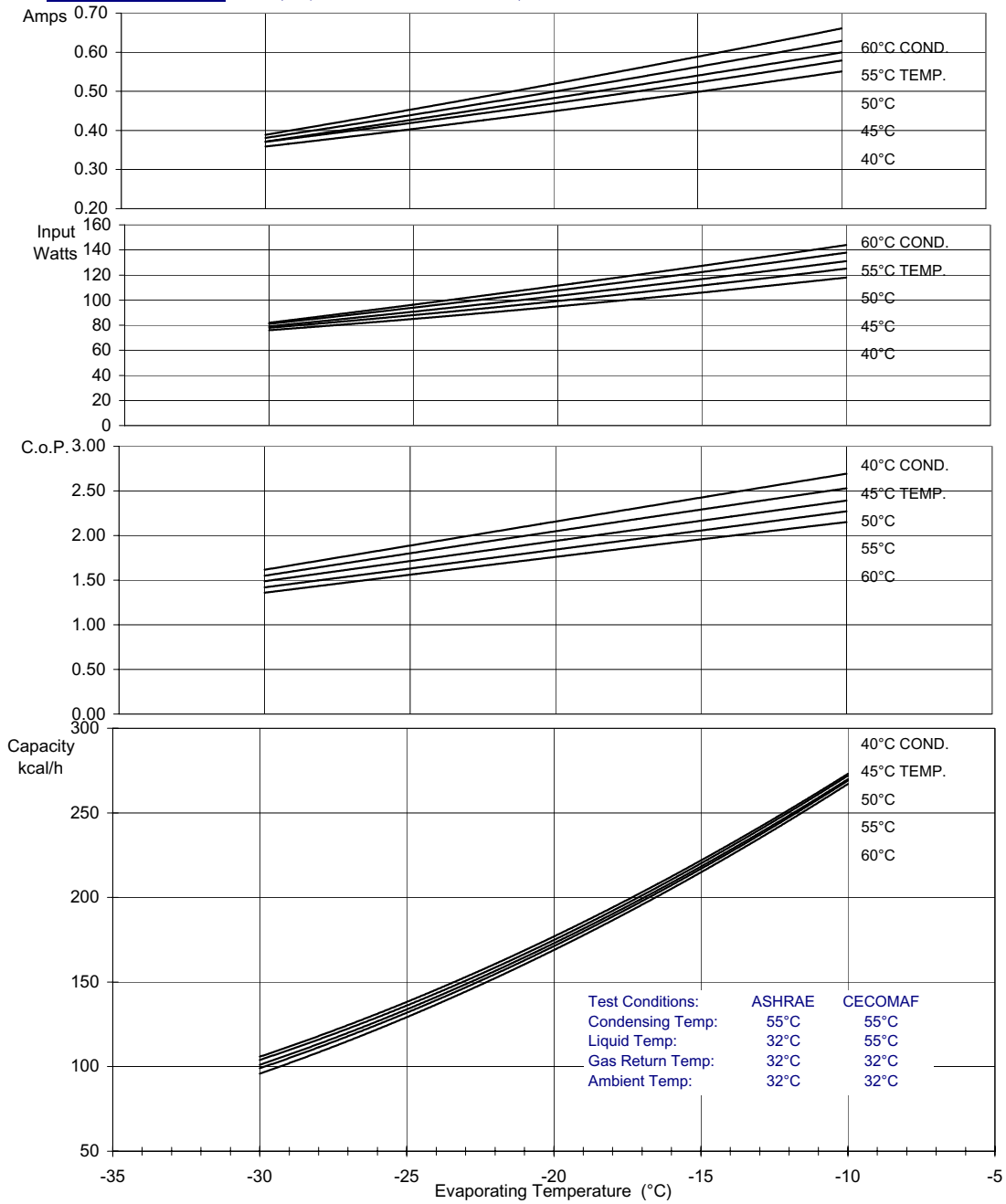

Test Conditions:	ASHRAE	CECOMAF
Condensing Temp:	55°C	55°C
Liquid Temp:	32°C	55°C
Gas Return Temp:	32°C	32°C
Ambient Temp:	32°C	32°C

	Evaporating Temperature °C	-30	-25	-23.3	-20	-15	-10	
<b>ASHRAE:</b>	Capacity	Kcal/h	99	132	144	171	217	269
	C.o.P.	W / W	1.42	1.63	1.70	1.84	2.06	2.27
<b>CECOMAF:</b>	Capacity	W	95	126		164	207	257
	C.o.P.	W / W	1.17	1.34		1.52	1.70	1.86
	Input Power	W	81	94	98	108	122	138
	Current	A	0.38	0.44	0.46	0.50	0.56	0.63

### Circuit Diagram for ECC Terminal Board Standard Version

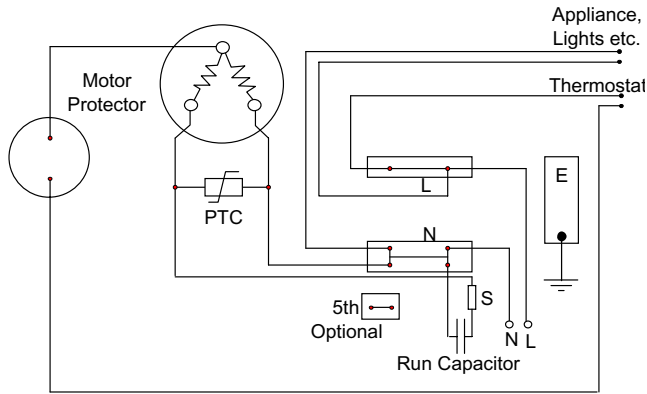

### Circuit Diagram for ECC Terminal Board Frontal Version

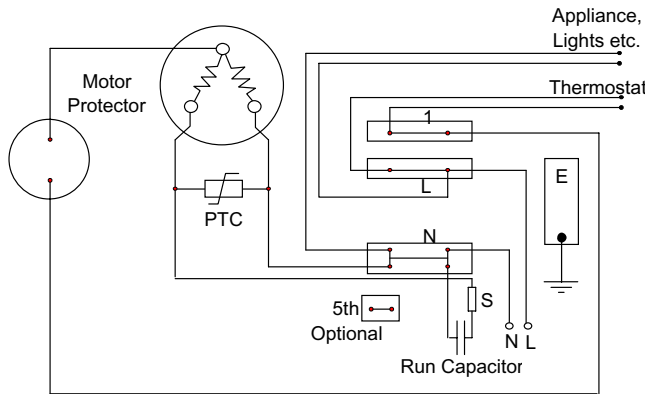

### Circuit Diagram for ECC Terminal Board Rast 5 Version

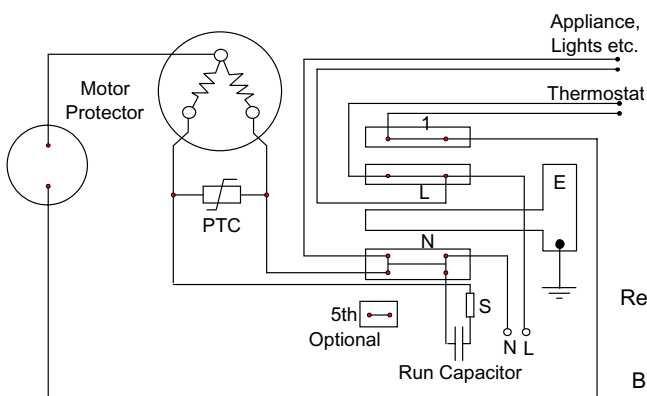

### Mounting Accessories

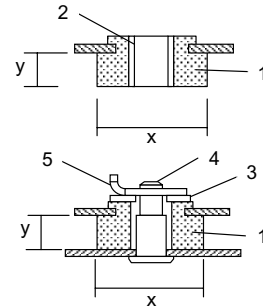

x = 26mm or 28.5mm  
y = 9mm or 10.3mm  
Other sizes available

1. Rubber grommet
2. Sleeve
3. Washer
4. Steel pin
5. Clip

### Recommended Transport Positions when fitted into appliances

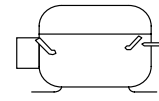

Upright

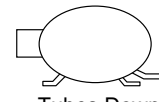

Tubes Down

### Compressor Label

