

# Technical Data Sheet

Compressor model **B25GL**  
 Voltage **220-240V 50Hz ~1**  
 Refrigerant **R134a**

## APPLICATION

## COMPRESSOR

## MOTOR

Application	High Back Pressure	Displacement	2,60 cm <sup>3</sup>	Nominal Power	1/14 hp
Refrigerant	R134a	Diameter	17,20 mm	Voltage/Frequency	220-240V 50Hz
Evaporating Temp.	-15,0 °C to 10,0 °C	Stroke	11,20 mm	Voltage range	187-255 V
Expansion	Capillar/Valve	Net Weight	5,35 Kg	Type	CSIR
Comp. Cooling	Static	Oil type	POE 32	Phase number	1 PH
Max. ambient temp.	43,0 °C	Oil charge	120 cm <sup>3</sup>	Locked Rotor Amps (LRA)	5,60 A
Compatible refriger.	R1234yf			Main W. resist. at 25°C	28,80 Ω
				Start W. resist. at 25°C	10,40 Ω

## NOMINAL PERFORMANCE

	ASHRAE	CECOMAF
Cooling Capacity	196 kCal/h	186 W
COP	2,16 W/W	1,81 W/W
EER	1,85 kCal/Wh	1,56 kCal/Wh
Input Power	106 W	103 W
Current	0,71 A	0,70 A

## APPROVALS



## TEST CYCLE CONDITIONS

	ASHRAE HBP (D)	CECOMAF HBP (C)
Evaporating temp. (T <sub>e</sub> )	7,2 °C	5,0 °C
Condensing temp. (T <sub>c</sub> )	55,0 °C	55,0 °C
Liquid temp. (T <sub>liq.</sub> )	46,0 °C	55,0 °C
Ambient temp. (T <sub>amb.</sub> )	35,0 °C	32,0 °C
Suction temp. (T <sub>suction</sub> )	35,0 °C	32,0 °C
Voltage/Frequency	220 V 50 Hz	220 V 50 Hz

## ELECTRICAL COMPONENTS

Starting capacitor	61 µF 330 V			
Relay	Option 1			
Reference	QL2-2.40 B3 (014)			
Pick-Up	2.4 A			
Drop-Out	2 A			
Protector	Option 1			
Reference	DRB16N61A1 (087)			
Current	3,50 A			
Time check	7-16 seg			
Disc temp. (Open/Close)	120,00 / 61,00 °C			

## ASHRAE

Tc °C	Te °C	Cooling Capacity kCal/h	Consumption W	Current A	COP W/W	EER kCal/Wh
40	-15	89	68	0,60	1,53	1,31
40	-10	109	72	0,61	1,76	1,51
40	-5	137	77	0,63	2,08	1,79
40	0	174	81	0,64	2,49	2,14
40	5	219	86	0,65	2,97	2,55
40	7,2	241	88	0,66	3,20	2,75
40	10	272	90	0,67	3,51	3,01

45	-15	85	70	0,61	1,42	1,22
45	-10	102	75	0,62	1,59	1,36
45	-5	128	80	0,64	1,85	1,59
45	0	162	86	0,65	2,20	1,89
45	5	205	91	0,67	2,61	2,24
45	7,2	226	94	0,68	2,81	2,41
45	10	255	97	0,68	3,07	2,64

50	-15	80	71	0,61	1,31	1,13
50	-10	96	78	0,63	1,43	1,23
50	-5	119	84	0,65	1,65	1,42
50	0	151	90	0,67	1,94	1,67
50	5	191	97	0,68	2,29	1,97
50	7,2	211	100	0,69	2,46	2,12
50	10	239	103	0,70	2,69	2,31

55	-15	76	73	0,62	1,21	1,04
55	-10	89	80	0,64	1,28	1,10
55	-5	110	88	0,66	1,46	1,25
55	0	139	95	0,68	1,70	1,46
55	5	176	102	0,70	2,01	1,72
55	7,2	196	106	0,71	2,16	1,85
55	10	222	110	0,72	2,36	2,03

60	-15	72	75	0,62	1,11	0,96
60	-10	82	83	0,65	1,15	0,99
60	-5	101	91	0,67	1,28	1,10
60	0	127	100	0,69	1,49	1,28
60	5	162	108	0,71	1,75	1,51
60	7,2	180	111	0,72	1,88	1,62
60	10	205	116	0,73	2,06	1,77

65	-15	68	77	0,63	1,02	0,88
65	-10	75	86	0,65	1,02	0,88
65	-5	91	95	0,68	1,12	0,96
65	0	116	104	0,70	1,29	1,11
65	5	148	113	0,73	1,52	1,31
65	7,2	165	117	0,73	1,64	1,41
65	10	189	123	0,75	1,79	1,54

## CECOMAF

Tc °C	Te °C	Cooling Capacity W	Consumption W	Current A	COP W/W	EER kCal/Wh
40	-15	96	68	0,60	1,41	1,21
40	-10	118	73	0,62	1,62	1,40
40	-5	148	77	0,63	1,92	1,66
40	0	188	82	0,64	2,30	1,98
40	5	236	86	0,66	2,73	2,36
40	7,2	260	88	0,66	2,94	2,54
40	10	292	91	0,67	3,22	2,78

45	-15	91	70	0,61	1,30	1,12
45	-10	110	75	0,62	1,46	1,26
45	-5	138	81	0,64	1,70	1,47
45	0	174	86	0,66	2,02	1,74
45	5	219	92	0,67	2,39	2,06
45	7,2	242	94	0,68	2,57	2,22
45	10	273	97	0,69	2,81	2,42

50	-15	86	72	0,61	1,19	1,03
50	-10	102	78	0,63	1,30	1,13
50	-5	127	85	0,65	1,50	1,30
50	0	161	91	0,67	1,76	1,52
50	5	203	97	0,69	2,08	1,80
50	7,2	224	100	0,69	2,24	1,93
50	10	254	104	0,70	2,44	2,11

55	-15	81	74	0,62	1,09	0,95
55	-10	94	81	0,64	1,16	1,00
55	-5	116	88	0,66	1,32	1,14
55	0	147	96	0,68	1,54	1,33
55	5	186	103	0,70	1,81	1,56
55	7,2	206	106	0,71	1,94	1,68
55	10	235	110	0,72	2,13	1,84

60	-15	75	75	0,62	1,00	0,86
60	-10	86	84	0,65	1,03	0,89
60	-5	105	92	0,67	1,15	0,99
60	0	133	100	0,69	1,33	1,15
60	5	170	108	0,71	1,57	1,35
60	7,2	189	112	0,72	1,68	1,45
60	10	215	117	0,73	1,84	1,59

65	-15	70	77	0,63	0,91	0,79
65	-10	78	86	0,66	0,90	0,78
65	-5	95	96	0,68	0,99	0,85
65	0	120	105	0,71	1,14	0,99
65	5	153	114	0,73	1,35	1,16
65	7,2	171	118	0,74	1,45	1,25
65	10	196	123	0,75	1,59	1,37

## EN12900

X	Cooling Capacity (W)	Consumption (W)	Current (A)	Mass Flow (kg/h)
1	297,5373615436	45,9431888905	0,5502709429	4,9844298473289
2	13,2714067212	-0,6077221685	-0,0010269644	0,25370013903328
3	-2,8047135290	0,9475169873	0,0025056960	-0,022133137105438
4	0,1702902925	0,0011741204	-0,0000198409	0,0048161565833536
5	-0,1162755241	0,0389303160	0,0000915021	-0,0011854582718961

Equation	$x_1 + x_2Te + x_3Tc + x_4Te^2 + x_5TeTc$
----------	---

# Technical Data Sheet

## COMPRESSOR DIMENSIONS

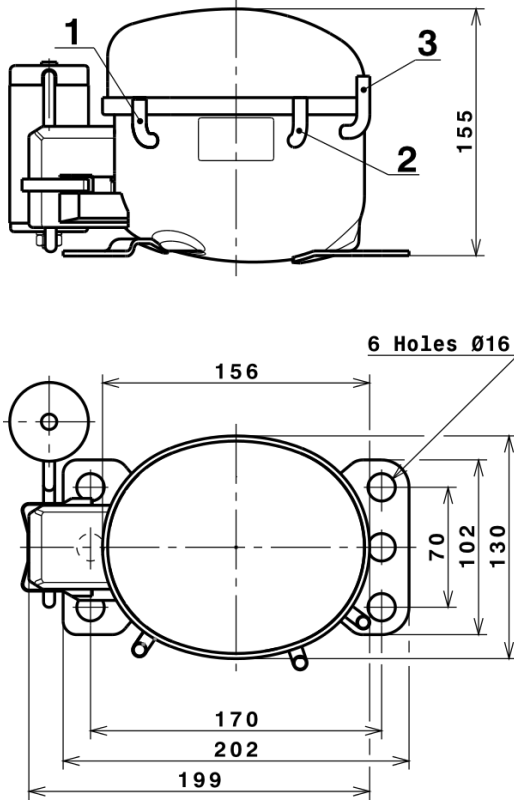

## DESIGNATION INTERNAL DIAM.

DESIGNATION	INTERNAL DIAM.
1 Suction	6,1 mm
2 Service	6,1 mm
3 Discharge	5,1 mm

## WIRING DIAGRAMS AND ELECTRICAL ASSEMBLY

### CSIR CONNECTION (B, Small L ranges)

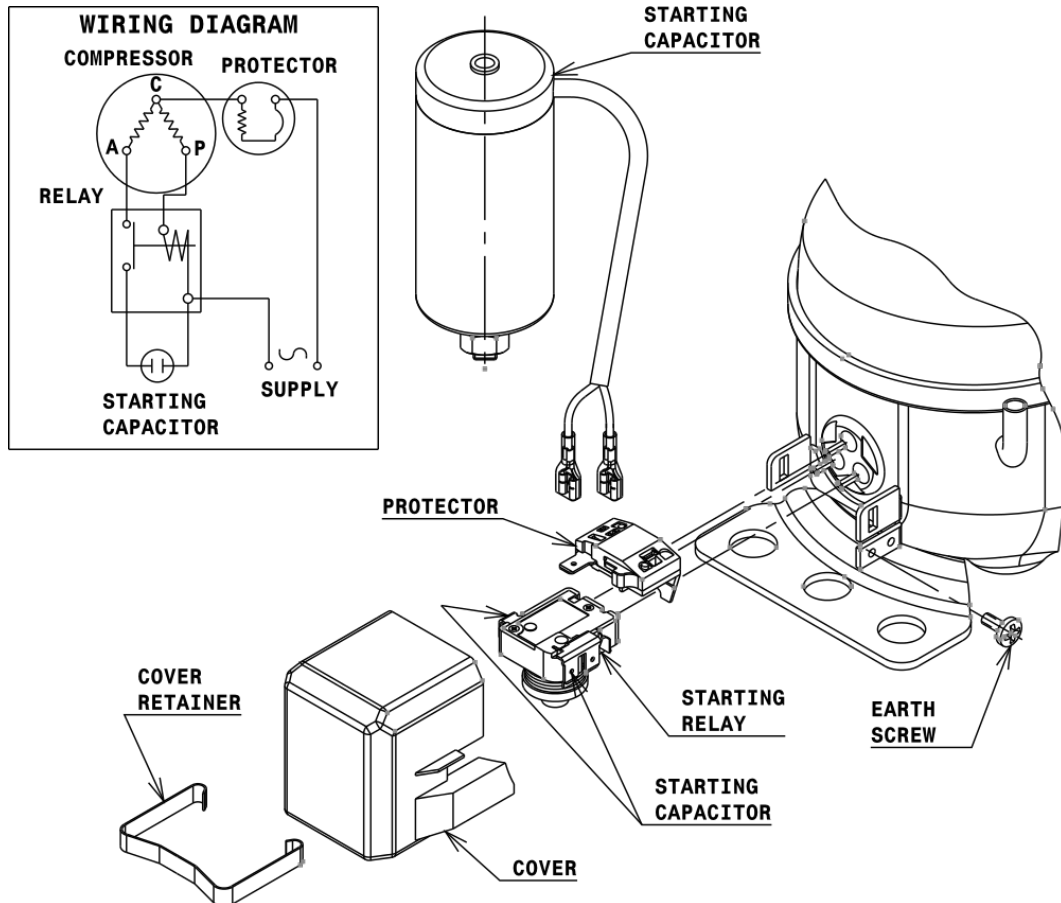

# Technical Data Sheet

## FIXINGS

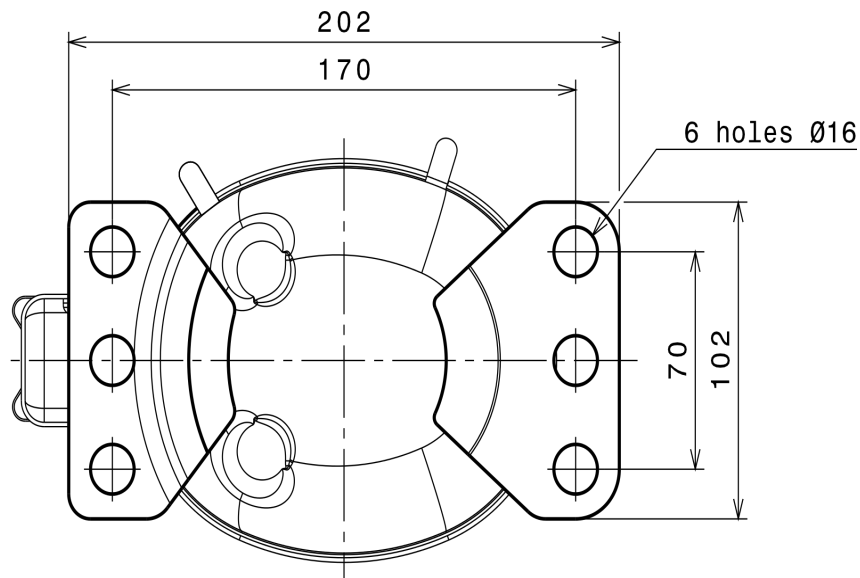

## SILENT BLOCKS (MOUNTING ACCESSORIES)

### STANDARD

Ø16 holes (170x70 net)

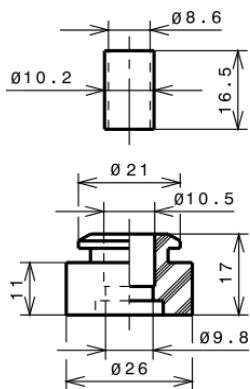

### SOA

SOA R134a HBP

