

Condensing Unit Technical Data Sheet

Compressor model **CGE70TG_N**
 Voltage **220-240/230V 50/60Hz ~1**
 Refrigerant **R134a**

APPLICATION		COMPRESSOR	MOTOR
Application	High Back Pressure	Displacement 6,70 cm ³	Nominal Power 1/5 hp
Refrigerant	R134a	Diameter 21,99 mm	Voltage/Frequency 230V 60Hz
Evaporating Temp.	-15,0 °C to 10,0 °C	Stroke 17,50 mm	Voltage range 196-253 V
Expansion	Capillar/Valve	Oil type ISO VG 22 ESTER	Type CSIR
Comp. Cooling	Fan cooled	Oil charge 220 cm ³	Phase number 1 PH
Max. ambient temp.	43,0 °C		Locked Rotor Amps (LRA) 14,00 A
			Max. Cont. Current (MCC) 0,00 A
			Main W. resist. at 25°C 10,50 Ω
			Start W. resist. at 25°C 23,30 Ω

NOMINAL PERFORMANCE	ASHRAE
Cooling Capacity	839 W
COP	2,25 W/W
EER	1,93 kCal/Wh
Input Power	373 W
Current	1,90 A

TEST CYCLE CONDITIONS	HBP
Evaporating temp. (T _e)	7,2 °C
Condensing temp. (T _c)	55,0 °C
Liquid temp. (T _{liq.})	46,0 °C
Ambient temp. (T _{amb.})	35,0 °C
Suction temp. (T _{suction})	35,0 °C
Voltage/Frequency	230 V 60 Hz

CONDENSER AND FAN DATA	
Condenser type	CU-AL
Condenser model	8T 3R
Fan blade (Ø mm / °)	200 / 28
Fan motor	5W 200V 50/60Hz

WIRING DIAGRAM

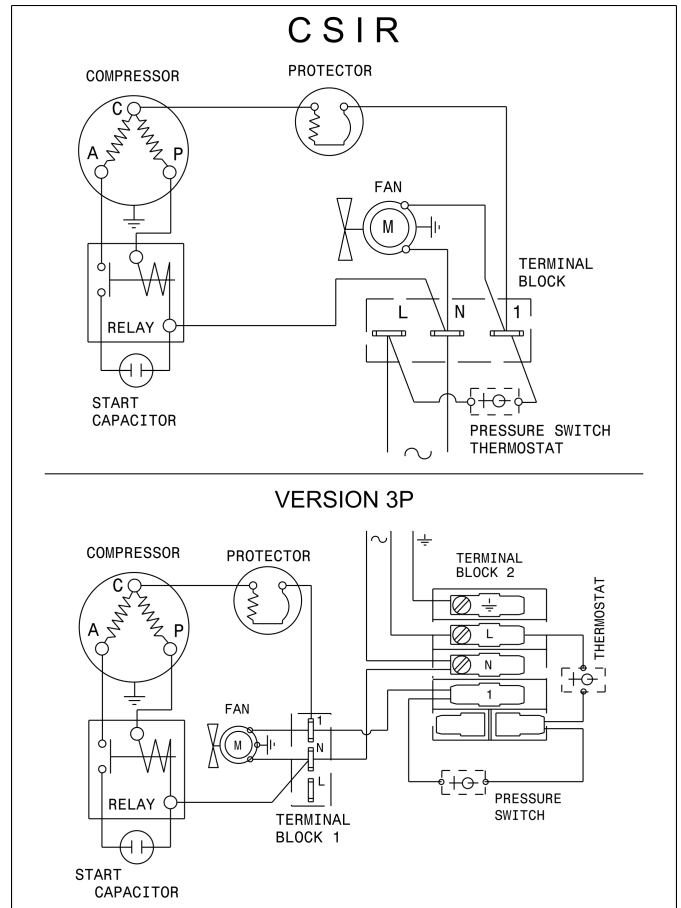

REFRIGERATION CAPACITY (W) Evaporating Temperature (Â°C)									
Model	Motor	-25	-15	-5	5	7.2			10
						W	Winp	A	
CGE70TG_N	CSIR	-	313	509	772	839	373	1.9	928

ASHRAE HBP: Condensing temperature: 55°C, Liquid temperature: 46°C, Suction temperature: 35°C, Ambient temperature: 35°C

Condensing Unit Technical Data Sheet

VERSIONS

VERSION 1	VERSION 2	VERSION 3	VERSION 3P	VERSION 4
Tube	Service valve	Service valve and receiver	Service valve, receiver, pressure switch	Schrader valve on the service port
Suction tube internal diam.: 6,2 mm Discharge tube internal diam.: 4,9 mm Net Weight: 13,5 Kg	Suction valve: 3/8" Discharge valve: 1/4" Net Weight: 14,0 Kg	Receiver vol.: 0,9 l Suction valve: 3/8" □□□: 1/4" Net Weight: 16,8 Kg	Receiver vol.: 0,9 l Suction valve: 3/8" Discharge valve: 1/4" Net Weight: 17,9 Kg	Suction tube internal diam.: 6,2 mm Discharge tube internal diam.: 4,9 mm Net Weight: 14,5 Kg

DIMENSIONS (Version 3 drawing)

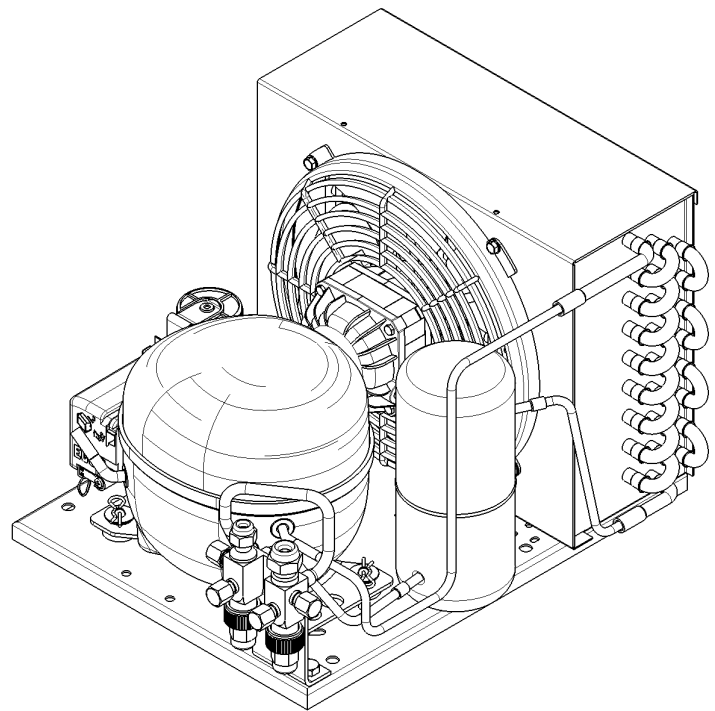
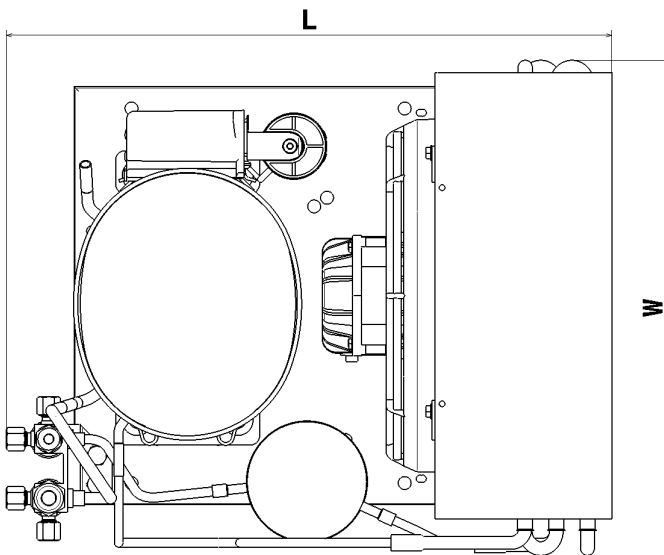
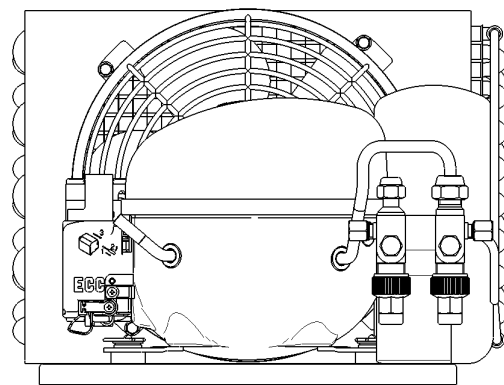
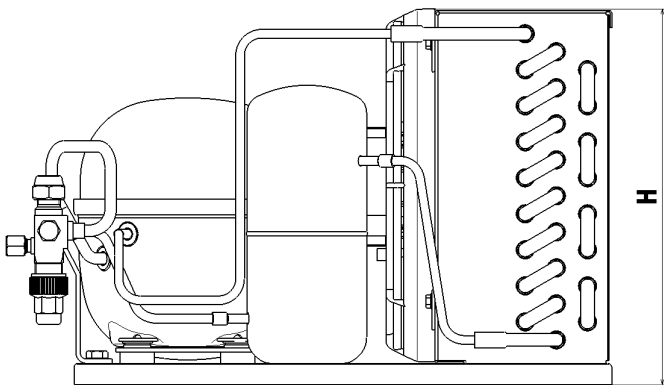

VERSION 1-4 (WxLxH) (mm)	VERSION 2 (WxLxH) (mm)	VERSION 3 (WxLxH) (mm)	VERSION 3P (WxLxH) (mm)
320x390x230	325x425x230	325x425x230	345x430x240