

Technical Data Sheet

Compressor model **HPY14AAa**
 Voltage **220-240V 50Hz ~1**
 Refrigerant **R600a**

APPLICATION

Application Low Back Pressure
 Refrigerant R600a
 Evaporating Temp. -35,0 °C to -10,0 °C
 Expansion Capillar
 Comp. Cooling Static
 Max. ambient temp. 43,0 °C

COMPRESSOR

Displacement 14,32 cm³
 Diameter 29,37 mm
 Stroke 21,13 mm
 Net Weight 11,41 Kg
 Oil type ISO VG 10 MINER
 Oil charge 300 cm³

MOTOR

Nominal Power 1/5 hp
 Voltage/Frequency 220-240V 50Hz
 Voltage range 187-264 V
 Type RSIR
 Phase number 1 PH
 Locked Rotor Amps (LRA) 11,50 A
 Max. Cont. Current (MCC) 1,30 A
 Main W. resist. at 25°C 12,69 Ω
 Start W. resist. at 25°C 17,08 Ω

NOMINAL PERFORMANCE

	ASHRAE	CECOMAF
Cooling Capacity	190 kCal/h	166 W
COP	1,43 W/W	1,13 W/W
EER	1,23 kCal/Wh	0,98 kCal/Wh
Input Power	154 W	146 W
Current	0,98 A	0,95 A

APPROVALS

TEST CYCLE CONDITIONS

	ASHRAE LBP (B)	CECOMAF LBP (A)
Evaporating temp. (T _e)	-23,3 °C	-25,0 °C
Condensing temp. (T _c)	55,0 °C	55,0 °C
Liquid temp. (T _{liq.})	32,0 °C	55,0 °C
Ambient temp. (T _{amb.})	32,0 °C	32,0 °C
Suction temp. (T _{suction})	32,0 °C	32,0 °C
Voltage/Frequency	220 V 50 Hz	220 V 50 Hz

ELECTRICAL COMPONENTS

Relay				
Reference				
Voltage				
Resistance				
Protector	Option 1	Option 2	Option 3	Option 4
Reference	MSP348LZ	4TM276NFBYY	T0502	AE15BU
Current	7,40 A	9,00 A	9,00 A	8,00 A
Time check	7,5-14 seg	5-15 seg	7,5-14 seg	7,5-14 seg
Disc temp. (Open/Close)	120,00 / 61,00 °C	120,00 / 61,00 °C	130,00 / 62,00 °C	120,00 / 62,00 °C

This product is approved for R290 and R600a regarding explosion safety according to standard EN 60335-1 and EN 60335-2-34

ASHRAE

Tc °C	Te °C	Cooling Capacity kCal/h	Consumption W	Current A	COP W/W	EER kCal/Wh
40	-35	117	105	0,81	1,30	1,11
40	-30	155	123	0,87	1,47	1,26
40	-25	202	141	0,93	1,66	1,43
40	-23,3	220	148	0,96	1,73	1,49
40	-20	259	161	1,01	1,87	1,60
40	-15	325	183	1,09	2,07	1,78
40	-10	401	205	1,18	2,28	1,96

45	-35	110	104	0,80	1,23	1,05
45	-30	146	123	0,87	1,38	1,19
45	-25	192	143	0,94	1,57	1,35
45	-23,3	210	150	0,97	1,63	1,40
45	-20	248	164	1,02	1,76	1,51
45	-15	313	186	1,11	1,95	1,68
45	-10	387	210	1,21	2,15	1,84

50	-35	103	104	0,80	1,16	0,99
50	-30	138	124	0,87	1,30	1,12
50	-25	183	145	0,94	1,47	1,26
50	-23,3	200	152	0,97	1,53	1,32
50	-20	237	167	1,03	1,65	1,42
50	-15	301	190	1,12	1,84	1,58
50	-10	374	215	1,23	2,02	1,74

55	-35	96	103	0,80	1,08	0,93
55	-30	130	124	0,87	1,22	1,05
55	-25	173	146	0,95	1,38	1,18
55	-23,3	190	154	0,98	1,43	1,23
55	-20	226	170	1,04	1,55	1,33
55	-15	288	194	1,14	1,73	1,48
55	-10	360	220	1,25	1,90	1,64

60	-35	89	102	0,80	1,01	0,87
60	-30	121	124	0,87	1,14	0,98
60	-25	163	148	0,96	1,29	1,11
60	-23,3	180	156	0,99	1,34	1,15
60	-20	215	172	1,05	1,45	1,25
60	-15	276	198	1,16	1,62	1,39
60	-10	346	225	1,27	1,79	1,54

CECOMAF

Tc °C	Te °C	Cooling Capacity W	Consumption W	Current A	COP W/W	EER kCal/Wh
40	-35	128	105	0,81	1,22	1,05
40	-30	172	123	0,87	1,40	1,21
40	-25	225	141	0,93	1,59	1,37
40	-23,3	245	148	0,96	1,65	1,43
40	-20	287	161	1,01	1,78	1,54
40	-15	358	183	1,09	1,96	1,69
40	-10	438	205	1,18	2,14	1,85

45	-35	116	104	0,80	1,11	0,96
45	-30	156	123	0,87	1,27	1,10
45	-25	205	143	0,94	1,44	1,24
45	-23,3	224	150	0,97	1,49	1,29
45	-20	263	164	1,02	1,61	1,39
45	-15	331	186	1,11	1,77	1,53
45	-10	407	210	1,21	1,94	1,67

50	-35	104	104	0,80	1,00	0,87
50	-30	140	124	0,87	1,14	0,98
50	-25	186	145	0,94	1,28	1,11
50	-23,3	203	152	0,97	1,34	1,15
50	-20	240	167	1,03	1,44	1,24
50	-15	303	190	1,12	1,59	1,38
50	-10	376	215	1,23	1,75	1,51

55	-35	92	103	0,80	0,89	0,77
55	-30	124	124	0,87	1,00	0,87
55	-25	166	146	0,95	1,13	0,98
55	-23,3	182	154	0,98	1,18	1,02
55	-20	216	170	1,04	1,28	1,10
55	-15	276	194	1,14	1,42	1,23
55	-10	345	220	1,25	1,57	1,35

60	-35	80	102	0,80	0,78	0,68
60	-30	109	124	0,87	0,87	0,75
60	-25	146	148	0,96	0,99	0,85
60	-23,3	161	156	0,99	1,03	0,89
60	-20	193	172	1,05	1,12	0,97
60	-15	249	198	1,16	1,25	1,08
60	-10	313	225	1,27	1,39	1,20

EN12900

X	Cooling Capacity (W)	Consumption (W)	Current (A)	Mass Flow (kg/h)
1	926,9783771252	199,9073423730	1,1750583191	9,3658825032184
2	26,3273362499	3,3705553782	0,0170148771	0,29268552376478
3	-7,8998139197	1,4859370163	0,0064526042	-0,04292234166559
4	0,1755608898	0,0250810961	0,0002060832	0,0025508742082015
5	-0,1573214759	0,0463452785	0,0001972565	-0,00070688208109825

Equation	$x_1 + x_2Te + x_3Tc + x_4Te^2 + x_5TeTc$
----------	---

Technical Data Sheet

COMPRESSOR DIMENSIONS

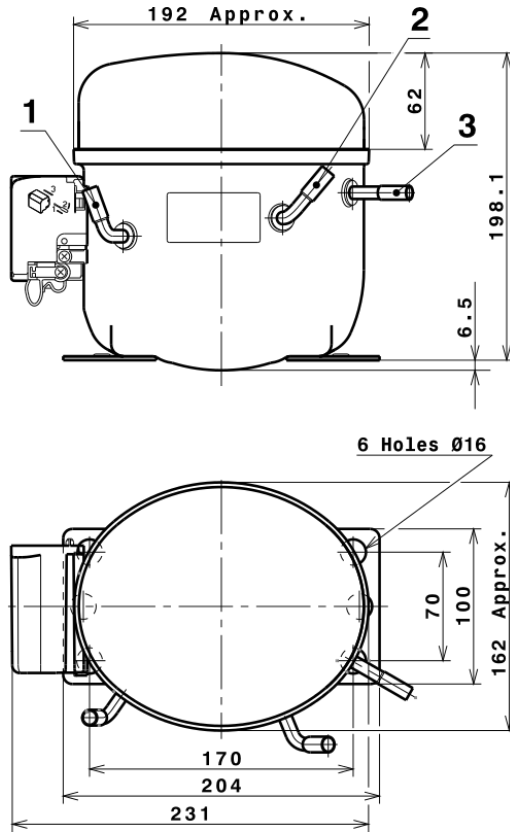

DESIGNATION INTERNAL DIAM.

DESIGNATION	INTERNAL DIAM.
1	Suction 8,1 mm
2	Service 8,1 mm
3	Discharge 6,5 mm

WIRING DIAGRAMS AND ELECTRICAL ASSEMBLY

RSIR CONNECTION (PTC) (L, P ranges)



Technical Data Sheet

FIXINGS



SILENT BLOCKS (MOUNTING ACCESSORIES)

STANDARD

Ø16 holes (170x70 net)

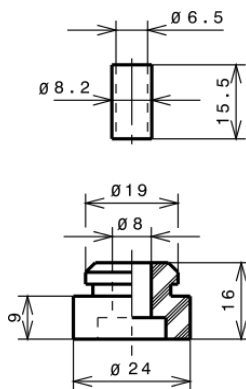

SNAP-ON

Ø16 holes (170x70 net)

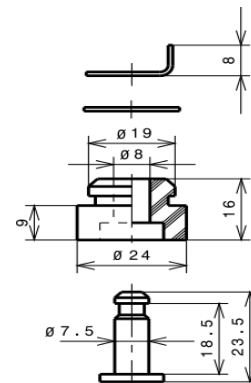

SOA

SOA R600a LBP

