

Technical Data Sheet

Compressor model **MPT12RG**
 Voltage **200-220/220-230V 50/60Hz ~1**
 Refrigerant **R404A**

APPLICATION		COMPRESSOR		MOTOR	
Application	High Back Pressure	Displacement	12,10 cm ³	Nominal Power	3/8 hp
Refrigerant	R404A	Diameter	27,00 mm	Voltage/Frequency	220-230V 60Hz
Evaporating Temp.	-15,0 °C to 10,0 °C	Stroke	21,13 mm	Voltage range	198-253 V
Expansion	Capillar/Valve	Net Weight	12,89 Kg	Type	CSR
Comp. Cooling	Fan cooled	Oil type	ISO VG 32 ESTER	Phase number	1 PH
Max. ambient temp.	43,0 °C	Oil charge	400 cm ³	Locked Rotor Amps (LRA)	22,50 A
				Max. Cont. Current (MCC)	6,60 A
				Main W. resist. at 25°C	2,87 Ω
				Start W. resist. at 25°C	7,59 Ω

NOMINAL PERFORMANCE

	ASHRAE	CECOMAF
Cooling Capacity	1.874 kCal/h	1.725 W
COP	2,22 W/W	1,79 W/W
EER	1,91 kCal/Wh	1,55 kCal/Wh
Input Power	983 W	964 W
Current	4,38 A	4,29 A

APPROVALS



TEST CYCLE CONDITIONS

	ASHRAE HBP (D)	CECOMAF HBP (C)
Evaporating temp. (T _e)	7,2 °C	5,0 °C
Condensing temp. (T _c)	55,0 °C	55,0 °C
Liquid temp. (T _{liq.})	46,0 °C	55,0 °C
Ambient temp. (T _{amb.})	35,0 °C	32,0 °C
Suction temp. (T _{suction})	35,0 °C	32,0 °C
Voltage/Frequency	230 V 60 Hz	230 V 60 Hz

ELECTRICAL COMPONENTS

Starting capacitor	72- 88 µF 330 V		
Run capacitor	20 µF 420 V		
Relay	Option 1	Option 2	
Reference	2014 158. + NTC15Ω	QLZ-9.05A + NTC15Ω	
Pick-Up	9,05 A	9,05 A	
Drop-Out	7,70 A	7,70 A	
Protector	Option 1		
Reference	T0253		
Current	15,00 A		
Time check	7,5-14 seg		
Disc temp. (Open/Close)	105,00 / 52,00 °C		

ASHRAE

Tc °C	Te °C	Cooling Capacity kCal/h	Consumption W	Current A	COP W/W	EER kCal/Wh
40	-15	1.011	676	3,15	1,74	1,50
40	-10	1.247	720	3,31	2,02	1,73
40	-5	1.519	764	3,47	2,31	1,99
40	0	1.827	807	3,63	2,63	2,26
40	5	2.171	849	3,80	2,97	2,56
40	7,2	2.333	868	3,88	3,13	2,69
40	10	2.550	891	3,97	3,33	2,86

45	-15	939	688	3,19	1,59	1,36
45	-10	1.157	738	3,37	1,82	1,57
45	-5	1.411	788	3,56	2,08	1,79
45	0	1.700	837	3,75	2,36	2,03
45	5	2.026	885	3,95	2,66	2,29
45	7,2	2.180	906	4,04	2,80	2,41
45	10	2.386	932	4,15	2,98	2,56

50	-15	867	701	3,24	1,44	1,24
50	-10	1.067	757	3,44	1,64	1,41
50	-5	1.302	812	3,65	1,87	1,60
50	0	1.574	867	3,87	2,11	1,82
50	5	1.881	921	4,10	2,38	2,04
50	7,2	2.027	945	4,21	2,50	2,15
50	10	2.223	974	4,34	2,65	2,28

55	-15	795	713	3,28	1,30	1,12
55	-10	977	775	3,51	1,47	1,26
55	-5	1.194	836	3,75	1,66	1,43
55	0	1.447	897	4,00	1,88	1,61
55	5	1.736	957	4,26	2,11	1,81
55	7,2	1.874	983	4,38	2,22	1,91
55	10	2.060	1.016	4,53	2,36	2,03

60	-15	723	726	3,32	1,16	1,00
60	-10	886	793	3,58	1,30	1,12
60	-5	1.086	861	3,85	1,47	1,26
60	0	1.320	927	4,13	1,66	1,42
60	5	1.591	993	4,43	1,86	1,60
60	7,2	1.721	1.022	4,56	1,96	1,68
60	10	1.897	1.058	4,73	2,09	1,79

CECOMAF

Tc °C	Te °C	Cooling Capacity W	Consumption W	Current A	COP W/W	EER kCal/Wh
40	-15	1.059	680	3,16	1,56	1,35
40	-10	1.311	724	3,32	1,81	1,56
40	-5	1.596	769	3,48	2,08	1,79
40	0	1.916	812	3,65	2,36	2,04
40	5	2.271	855	3,83	2,65	2,29
40	7,2	2.438	874	3,90	2,79	2,41
40	10	2.660	898	4,00	2,96	2,56

45	-15	971	692	3,21	1,40	1,21
45	-10	1.199	743	3,39	1,61	1,39
45	-5	1.461	793	3,58	1,84	1,59
45	0	1.758	843	3,77	2,09	1,80
45	5	2.089	892	3,98	2,34	2,02
45	7,2	2.245	913	4,07	2,46	2,12
45	10	2.454	940	4,19	2,61	2,26

50	-15	883	705	3,25	1,25	1,08
50	-10	1.087	761	3,46	1,43	1,23
50	-5	1.326	817	3,67	1,62	1,40
50	0	1.599	873	3,90	1,83	1,58
50	5	1.907	928	4,13	2,06	1,78
50	7,2	2.053	952	4,24	2,16	1,86
50	10	2.248	982	4,38	2,29	1,98

55	-15	795	717	3,30	1,11	0,96
55	-10	976	780	3,53	1,25	1,08
55	-5	1.191	842	3,77	1,41	1,22
55	0	1.441	903	4,03	1,60	1,38
55	5	1.725	964	4,29	1,79	1,55
55	7,2	1.860	991	4,41	1,88	1,62
55	10	2.043	1.024	4,57	1,99	1,72

60	-15	707	730	3,34	0,97	0,84
60	-10	864	798	3,60	1,08	0,94
60	-5	1.056	866	3,87	1,22	1,05
60	0	1.282	934	4,16	1,37	1,19
60	5	1.543	1.000	4,46	1,54	1,33
60	7,2	1.668	1.029	4,60	1,62	1,40
60	10	1.837	1.066	4,77	1,72	1,49

EN12900

X	Cooling Capacity (W)	Consumption (W)	Current (A)	Mass Flow (kg/h)
1	3.191,3546140891	586,5151743306	2,6125940918	60,190705497245
2	105,8074870153	-0,4750533642	-0,0110480064	2,2340444128285
3	-33,1729365828	6,2592998941	0,0278790688	-0,18562615017871
4	0,6495197743	0,0010308009	0,0003213702	0,032805265145259
5	-1,0044588431	0,2452991401	0,0012385120	-0,0031200339649164

Equation	$x_1 + x_2Te + x_3Tc + x_4Te^2 + x_5TeTc$
----------	---

Technical Data Sheet

COMPRESSOR DIMENSIONS

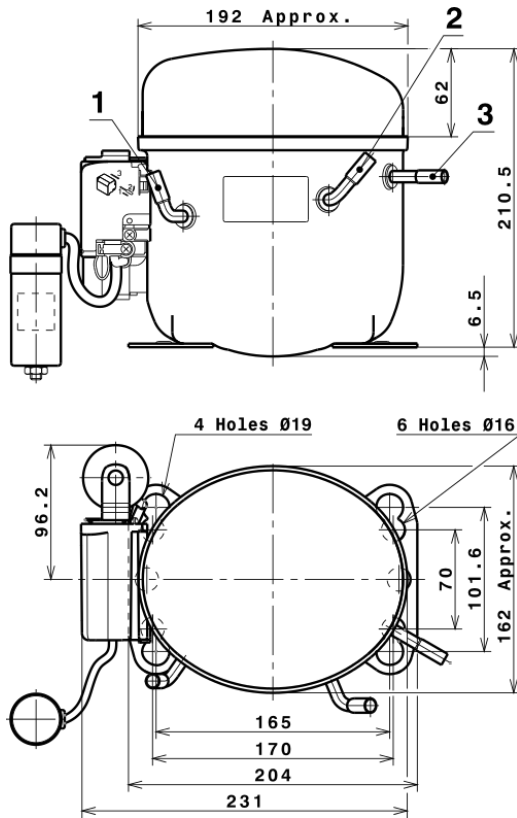

DESIGNATION INTERNAL DIAM.

DESIGNATION	INTERNAL DIAM.
1 Suction	8,1 mm
2 Service	8,1 mm
3 Discharge	6,5 mm

WIRING DIAGRAMS AND ELECTRICAL ASSEMBLY

CSR CONNECTION (CURRENT RELAY + NTC) (L, P ranges)

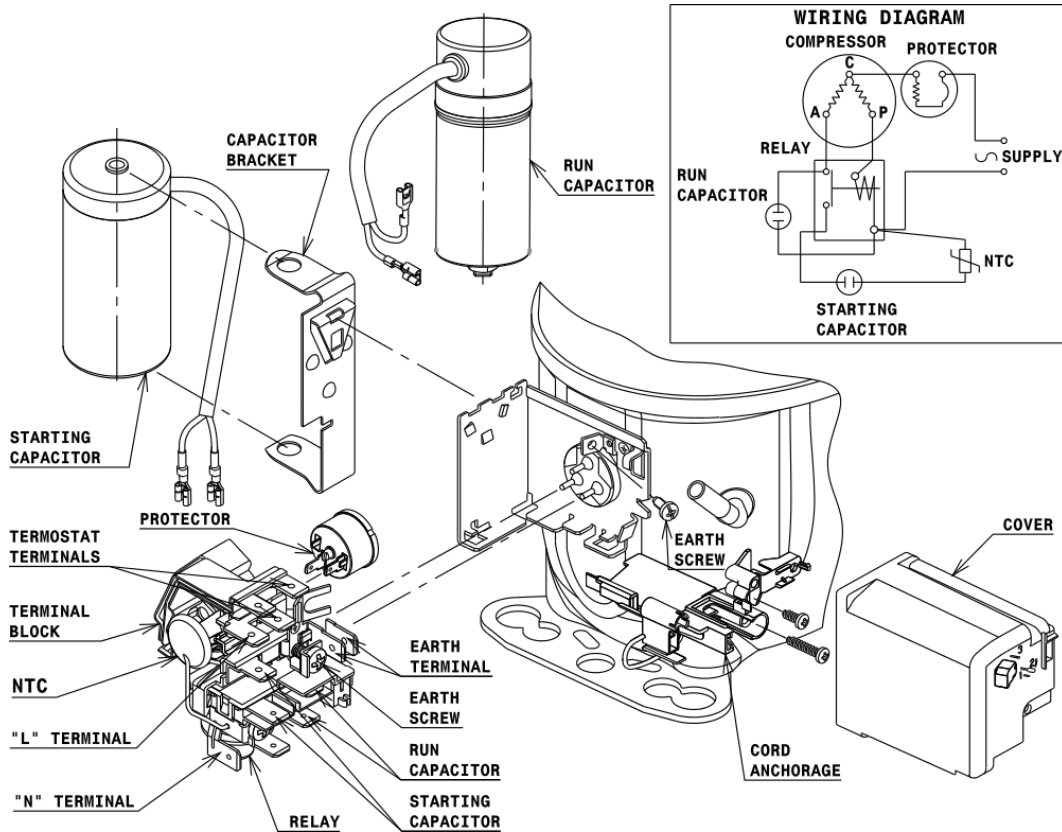

Technical Data Sheet

FIXINGS



SILENT BLOCKS (MOUNTING ACCESSORIES)

STANDARD

Ø16 holes (170x70 net)



AMERICAN FEET

Ø19 holes (165x101.6 net)



SNAP-ON

Ø16 holes (170x70 net)



SOA

SOA R404A HBP

