

Technical Data Sheet

Compressor model **NPT16LA**
 Voltage **220-240V 50Hz ~1**
 Refrigerant **R290**

APPLICATION

Application	Low Back Pressure
Refrigerant	R290
Evaporating Temp.	-40,0 °C to -10,0 °C
Expansion	Capillar/Valve
Comp. Cooling	Fan cooled
Max. ambient temp.	43,0 °C

COMPRESSOR

Displacement	16,15 cm ³
Diameter	31,19 mm
Stroke	21,13 mm
Net Weight	12,17 Kg
Oil type	ISO VG 32 ESTER
Oil charge	400 cm ³

MOTOR

Nominal Power	1/2 hp
Voltage/Frequency	220-240V 50Hz
Voltage range	187-255 V
Type	CSR
Phase number	1 PH
Locked Rotor Amps (LRA)	19,00 A
Max. Cont. Current (MCC)	3,50 A
Main W. resist. at 25°C	5,30 Ω
Start W. resist. at 25°C	8,70 Ω

NOMINAL PERFORMANCE

	ASHRAE	CECOMAF
Cooling Capacity	650 kCal/h	564 W
COP	1,50 W/W	1,16 W/W
EER	1,29 kCal/Wh	1,00 kCal/Wh
Input Power	504 W	486 W
Current	2,48 A	2,40 A

APPROVALS



TEST CYCLE CONDITIONS

	ASHRAE LBP (B)	CECOMAF LBP (A)
Evaporating temp. (T _e)	-23,3 °C	-25,0 °C
Condensing temp. (T _c)	55,0 °C	55,0 °C
Liquid temp. (T _{liq.})	32,0 °C	55,0 °C
Ambient temp. (T _{amb.})	32,0 °C	32,0 °C
Suction temp. (T _{suction})	32,0 °C	32,0 °C
Voltage/Frequency	220 V 50 Hz	220 V 50 Hz

ELECTRICAL COMPONENTS

	Option 1	Option 2	Option 3
Starting capacitor	72- 88 µF 330 V		
Run capacitor	12 µF 420 V		
Relay	Option 1	Option 2	
Reference	2014 158. + NTC15İ©	QLZ-9.05A + NTC15İ©	
Pick-Up	9,05 A	9,05 A	
Drop-Out	7,70 A	7,70 A	
Protector	Option 1	Option 2	Option 3
Reference	MRA38139	T0269	B113-105
Current	10,30 A	9,60 A	11,50 A
Time check	7,5-14 seg	7,5-14 seg	7,5-16 seg
Disc temp. (Open/Close)	105,00 / 52,00 °C	105,00 / 52,00 °C	110,00 / 52,00 °C

This product is approved for R290 and R600a regarding explosion safety according to standard EN 60335-1 and EN 60335-2-34

ASHRAE

Tc °C	Te °C	Cooling Capacity kCal/h	Consumption W	Current A	COP W/W	EER kCal/Wh
40	-40	309	335	1,78	1,07	0,92
40	-35	409	371	1,92	1,28	1,10
40	-30	532	410	2,08	1,51	1,30
40	-25	678	451	2,25	1,75	1,50
40	-23,3	732	466	2,32	1,83	1,57
40	-20	846	496	2,45	1,98	1,70
40	-15	1.036	544	2,66	2,21	1,90
40	-10	1.249	595	2,89	2,44	2,10

45	-40	296	337	1,78	1,02	0,88
45	-35	392	376	1,94	1,21	1,04
45	-30	511	418	2,11	1,42	1,22
45	-25	652	463	2,30	1,64	1,41
45	-23,3	705	479	2,37	1,71	1,47
45	-20	815	511	2,51	1,86	1,60
45	-15	1.001	562	2,74	2,07	1,78
45	-10	1.210	616	2,98	2,28	1,96

50	-40	283	339	1,79	0,97	0,83
50	-35	375	381	1,96	1,14	0,98
50	-30	489	426	2,15	1,33	1,15
50	-25	626	474	2,35	1,53	1,32
50	-23,3	677	491	2,43	1,60	1,38
50	-20	785	526	2,57	1,74	1,49
50	-15	967	580	2,82	1,94	1,67
50	-10	1.171	637	3,08	2,14	1,84

55	-40	270	341	1,80	0,92	0,79
55	-35	357	386	1,98	1,08	0,93
55	-30	467	435	2,18	1,25	1,08
55	-25	600	486	2,40	1,44	1,23
55	-23,3	650	504	2,48	1,50	1,29
55	-20	755	540	2,64	1,62	1,40
55	-15	932	598	2,90	1,81	1,56
55	-10	1.132	658	3,18	2,00	1,72

60	-40	257	343	1,81	0,87	0,75
60	-35	340	391	2,00	1,01	0,87
60	-30	446	443	2,22	1,17	1,01
60	-25	574	497	2,45	1,34	1,15
60	-23,3	623	517	2,54	1,40	1,21
60	-20	724	555	2,71	1,52	1,31
60	-15	897	615	2,98	1,70	1,46
60	-10	1.093	679	3,28	1,87	1,61

CECOMAF

Tc °C	Te °C	Cooling Capacity W	Consumption W	Current A	COP W/W	EER kCal/Wh
40	-40	335	335	1,78	1,00	0,86
40	-35	453	371	1,92	1,22	1,06
40	-30	592	410	2,08	1,44	1,25
40	-25	751	451	2,25	1,66	1,44
40	-23,3	810	466	2,32	1,74	1,50
40	-20	931	496	2,45	1,88	1,62
40	-15	1.133	544	2,66	2,08	1,80
40	-10	1.355	595	2,89	2,28	1,97

45	-40	308	337	1,78	0,91	0,79
45	-35	414	376	1,94	1,10	0,95
45	-30	541	418	2,11	1,29	1,12
45	-25	689	463	2,30	1,49	1,29
45	-23,3	744	479	2,37	1,55	1,34
45	-20	857	511	2,51	1,68	1,45
45	-15	1.047	562	2,74	1,86	1,61
45	-10	1.257	616	2,98	2,04	1,76

50	-40	281	339	1,79	0,83	0,72
50	-35	375	381	1,96	0,99	0,85
50	-30	491	426	2,15	1,15	0,99
50	-25	626	474	2,35	1,32	1,14
50	-23,3	677	491	2,43	1,38	1,19
50	-20	783	526	2,57	1,49	1,29
50	-15	961	580	2,82	1,66	1,43
50	-10	1.159	637	3,08	1,82	1,57

55	-40	254	341	1,80	0,75	0,64
55	-35	337	386	1,98	0,87	0,75
55	-30	440	435	2,18	1,01	0,87
55	-25	564	486	2,40	1,16	1,00
55	-23,3	611	504	2,48	1,21	1,05
55	-20	709	540	2,64	1,31	1,13
55	-15	875	598	2,90	1,46	1,27
55	-10	1.062	658	3,18	1,61	1,39

60	-40	227	343	1,81	0,66	0,57
60	-35	298	391	2,00	0,76	0,66
60	-30	390	443	2,22	0,88	0,76
60	-25	502	497	2,45	1,01	0,87
60	-23,3	545	517	2,54	1,05	0,91
60	-20	635	555	2,71	1,14	0,99
60	-15	789	615	2,98	1,28	1,11
60	-10	964	679	3,28	1,42	1,23

EN12900

X	Cooling Capacity (W)	Consumption (W)	Current (A)	Mass Flow (kg/h)
1	2.817,7532335806	500,3890773586	2,4435923696	26,774042369909
2	73,0618990468	6,9240369649	0,0344536380	0,78192623960782
3	-24,7648673880	5,6021909015	0,0265104772	-0,11989659818782
4	0,4066111421	0,0640533327	0,0004214332	0,0059686103264604
5	-0,4831791943	0,1298380662	0,0006219744	-0,0022021832757302

Equation	$x_1 + x_2Te + x_3Tc + x_4Te^2 + x_5TeTc$
----------	---

Technical Data Sheet

COMPRESSOR DIMENSIONS

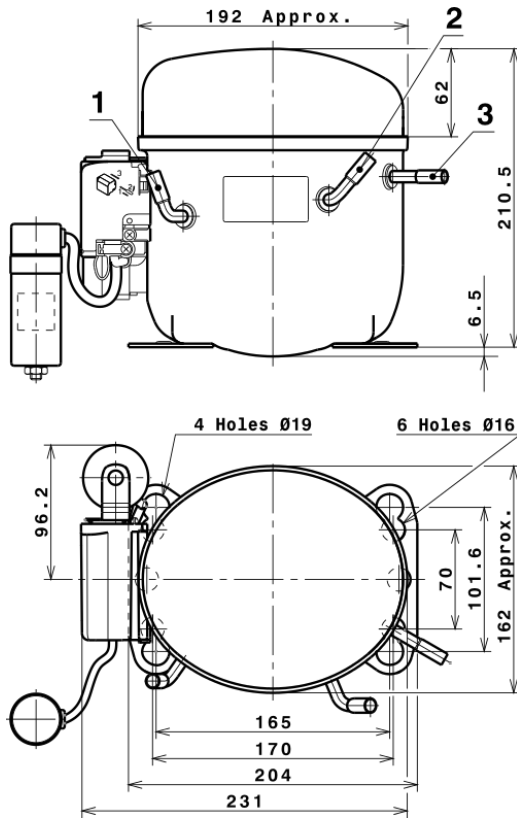

DESIGNATION INTERNAL DIAM.

DESIGNATION	INTERNAL DIAM.
1	Suction 8,1 mm
2	Service 8,1 mm
3	Discharge 6,5 mm

WIRING DIAGRAMS AND ELECTRICAL ASSEMBLY

CSR CONNECTION (CURRENT RELAY + NTC) (L, P ranges)

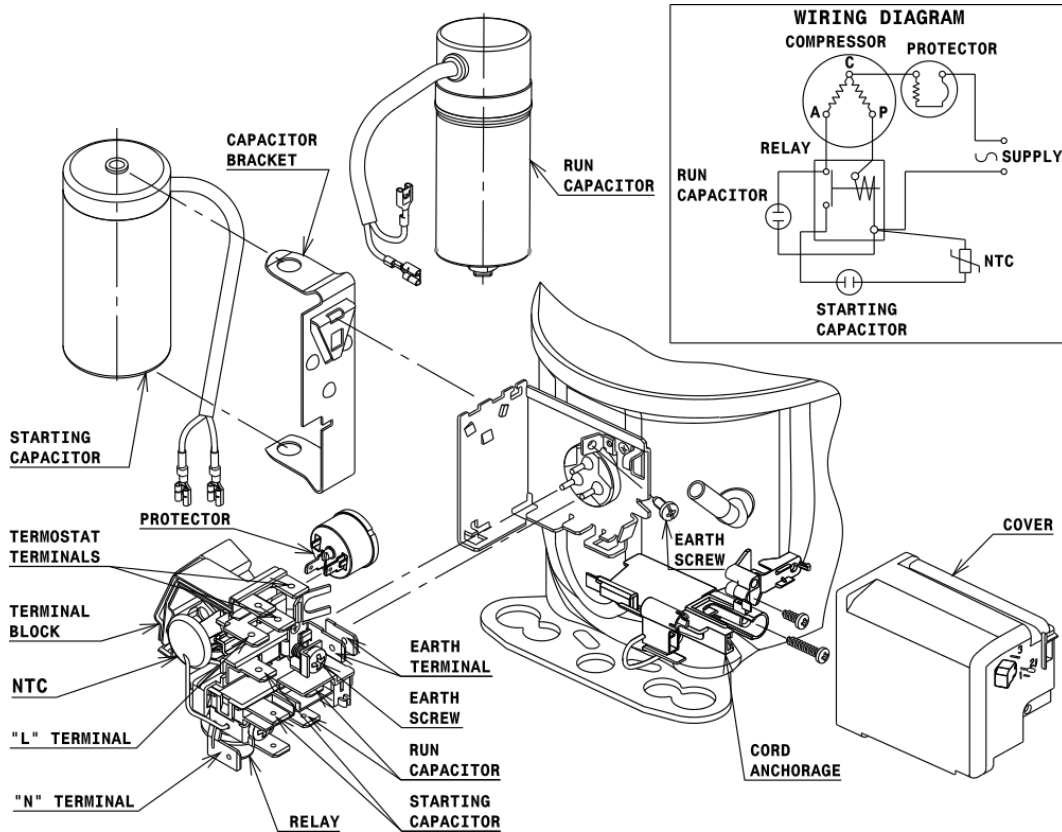

Technical Data Sheet

FIXINGS



SILENT BLOCKS (MOUNTING ACCESSORIES)

STANDARD

Ø16 holes (170x70 net)

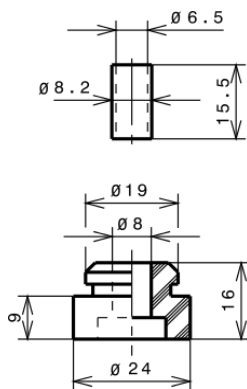

AMERICAN FEET

Ø19 holes (165x101.6 net)

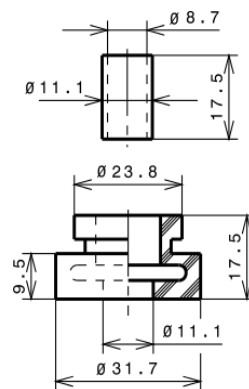

SNAP-ON

Ø16 holes (170x70 net)

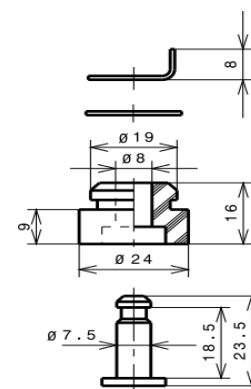

SOA

SOA R290 LBP

