

CCW

LABEL

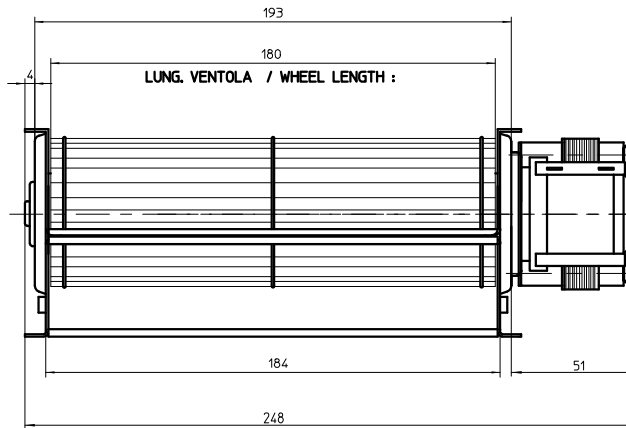

ATTACCO FASTON 6,3X0,8 (2 X)
FASTON CONNECTOR 6,3X0,8 (2 X)

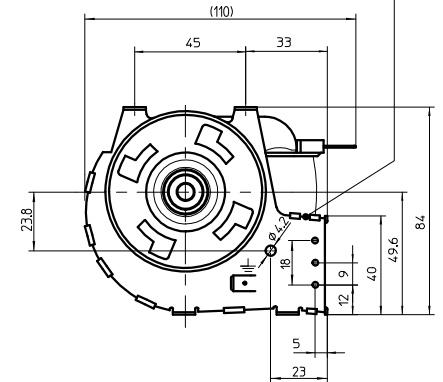

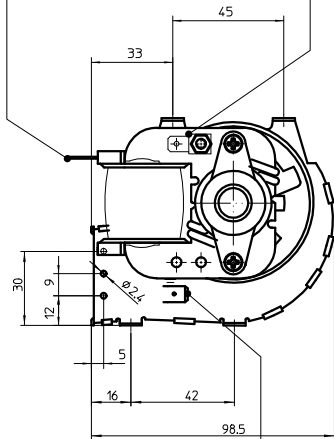
FASTON MASSA A TERRA 6,3X0,8
GROUND CONNECTOR 6,3X0,8



FASTON MASSA A TERRA 6,3X0,8
GROUND CONNECTOR 6,3X0,8

MOTORE OMOLOGATO  REG D720

MOTOR APPROVED  REG D720

Per approvazione/For approval		Dati tecnici a/Technical data at (-)		OPERATING POSITION : HORIZONTAL POS. DI FUNZIONAMENTO : ORIZZONTALE			DATA E REVISIONE/REVISION REF. AND DATE		
Firma/Signature:	T. FUNZIONAMENTO/WORKING TEMPERATURE [°C]:	70		DESCRIZIONE/DESCRIPTION	CROSS-FLOW BLOWER	DESIGN	R.R	DATE	05/07/19
	CLASSE DI ISOLAMENTO/INSULATION CLASS:	H			VENTILATORE TANGENZIALE	CHECKED	-	DATE	-
Data/Date:	PROTEZIONE TERMICA/THERMAL PROTECTOR [°C]:	160		TIPO/TYPE	TGA 60/1-180/15	 TOLERANCES IN ACCORDANCE WITH ISO 2768-m			
	TENSIONE-FREQUENZA/VOLTAGE-FREQUENCY [V/Hz]:	230/50		FERGAS south europe CODE	112763				
	AMPERAGGIO/CURRENT [mA]:	186							
	POTENZA ASSORBITA/INPUT POWER [w]:	22							
	VELOCITA'/SPEED [RPM]:	1720							
	PORTATA/AIRFLOW [m3/h]:	124							
PRESSIONE STATICA/STATIC PRESSURE [Pa]:	44								
						Dwg. no. 112763 A			

QUESTO DISEGNO APPARTIENE A FERGAS S.E. NON PUO' ESSERE RIPRODOTTO O CEDUTO A TERZI SENZA AUTORIZZAZIONE - BY LAW THE CURRENT DRAWING BELONGS TO FERGAS S.E. IT CAN'T BE REPRODUCED OR PASSED TO A THIRD PART WITHOUT AUTHORIZATION