







XWEB300D/500D/500B PRO (V.2.0)

CONTENTS

1. PRODUCT DISPOSAL (WEEE)	5
2. FOR WHOM THIS MANUAL IS INTENDED	5
3. PACKAGE CONTENTS	6
4. TECHNICAL FEATURES	7
5. INSTALLATION	8
5.1 INSTALL XWEB300D / 500D.....	9
5.1.1 LED	10
5.2 Installing XWEB500B	11
5.2.1 LED	12
5.3 CONNECT THE DEVICES	12
5.3.1 XC400/600/800/900 and XH200/300/400 SERIES CONFIGURATION	14
5.3.2 CONFIGURATION OF MODELS XJA/XJP/XJM	14
6. REMOTE CONNECTIVITY	14
6.1 DESKTOP SOFTWARE REQUIREMENTS (PC).....	14
6.2 MOBILE SOFTWARE REQUIREMENTS (SMARTPHONE/TABLET)	15
6.3 CROSS-CABLE CONNECTIVITY.....	16
6.4 INTRANET CONNECTIVITY (LAN CONNECTION) AND VPN	17
6.5 INTERNET CONNECTIVITY ON PUBLIC IP	18
6.6 WIFI CONNECTIVITY	19
7. EMERGENCY PROCEDURE	20
8. OPERATIVITY	22
9. SYSTEM DATA	22
10. TRADEMARKS	22
11. NOTES	23

CAUTION: IN ORDER TO PREVENT THE DEVELOPMENT OF FLAME OR ELECTRIC SHOCK, AVOID CONTACT OF THIS EQUIPMENT WITH RAIN OR WATER

	<p>CAUTION RISK OF ELECTRIC SHOCK DO NOT OPEN</p>		<p>CAUTION: TO REDUCE THE RISK OF ELECTRIC SHOCK, DO NOT REMOVE THE COVER. THERE ARE NO COMPONENTS INSIDE THAT REQUIRE SERVICING BY THE USER. ALWAYS HAVE QUALIFIED PERSONNEL CARRY OUT SERVICING.</p>
			<p>THE SYMBOL CONSISTING OF A LIGHTNING BOLT WITHIN AN EQUILATERAL TRIANGLE IS INTENDED TO ALERT THE USER TO THE PRESENCE OF POTENTIALLY DANGEROUS UNINSULATED ELECTRICAL VOLTAGE</p>
			<p>THE EXCLAMATION MARK WITHIN AN EQUILATERAL TRIANGLE IS INTENDED TO ALERT THE USER TO THE NEED TO PAY PARTICULAR ATTENTION TO THE CONTENTS OF THIS MANUAL</p>





CAUTION	<p>This device must be installed exclusively by qualified staff with suitable technical training and experience, who are aware of the dangers that they are exposed to. The operations described herein are set forth exclusively for the service staff. The user is not authorised to open the device</p>
	

CAUTION	<p>Only use modems and USB devices officially supported by this monitoring unit. Copeland Controls S.r.l. cannot be held liable for any malfunction or damage resulting from the use of unsupported devices.</p>
	

CAUTION	<p>Copeland Controls S.r.l. reserves the right to make changes to this manual without prior notice. The latest available version can be downloaded from the website.</p>
	

ATTENTION	<p>Immediately upon power supply failure no new data are recorded; all recorded data are retained in the non-volatile memory. The memory is electronic and no data is retained or transferred to other media such as paper. When the memory is full the oldest data is lost in order to store the most recent data. The product provides memory consumption indications on the user interface. The device does not have its own power supply. The recording interval is configurable between a minimum of 30 seconds and a maximum of 1 day. The duration of recordings depends on the interval and the number of points configured for each device in configuration. One year of data logging is guaranteed for 2 analogue resources at 15-minute intervals, per configured device. The selection of other resources may affect storage performance.</p>
	

CAUTION	<p>This is a class A product. In a residential environment it may cause radio interference. In such an eventuality, the user may have to take appropriate countermeasures.</p>
	

<p>CAUTION</p> 	<p>Copeland Controls S.r.l. reserves the right to vary the composition of its products, without informing the customer, guaranteeing in any case identical and unchanged function</p>
<p>CAUTION</p> 	<p>The product is not suitable for environments subject to mechanical vibrations and does not withstand impact. It must be installed in a dry and clean environment.</p>
<p>CAUTION</p> 	<p>The customer assumes full responsibility and risk for the configuration of the product to achieve the results of the installation and/or the final equipment/system. Upon the customer's request and following a specific agreement, Copeland Controls S.r.l. may be present during the start-up of the final machine/application, as a consultant, however, under no circumstances can the company be held responsible for the correct operation of the final equipment/system.</p>
<p>CAUTION</p> 	<p>Since Copeland Controls S.r.l. products form part of a very high level of technology, a qualification/configuration/programming/commissioning stage is required to use them as best as possible. Otherwise, these products may malfunction and Copeland Controls S.r.l. cannot be held responsible. The product must not be used in any way that differs from that stipulated in the documentation</p>

1. PRODUCT DISPOSAL (WEEE)

With reference to DIRECTIVE 2012/19/EU OF THE EUROPEAN PARLIAMENT AND OF THE COUNCIL of 4 July 2012 on Waste Electrical and Electronic Equipment (WEEE), and the relevant national implementing regulations, we would like to inform users of EEE in private households that:

- there is an obligation not to dispose of WEEE as unsorted municipal waste and to collect such WEEE separately;
- The public or private collection systems provided for by local laws must be used for disposal. It is also possible, at the end of its life, to return the equipment to the distributor if a new one is purchased.
- This equipment may contain hazardous substances; improper use or disposal could have negative effects on human health and the environment.
-  The symbol on the product or on the packaging indicates that the product should be treated as separate waste.
- In the event of improper disposal, sanctions may be applied as stipulated by current local waste disposal laws.

2. FOR WHOM THIS MANUAL IS INTENDED

This manual is intended for professional users such as the XWEB installer. Possibly also the administrator of the network that it will be connected to.

An integral part of this manual are the mechanical drawings of the product required for interventions and possible network configurations.

3. PACKAGE CONTENTS

Before opening the package, ensure that it is intact and shows no signs of impact or tampering. Before proceeding to any operation, it is recommended to check that the XWEB box contains:

- 1 XWEB unit
- 1 Quick Installation Guide
- 1 Ethernet cross cable
- 1 Power supply cable (XWEB500 only)
- Female plug-in connectors
 - XWEB300**
 - 2x2 ways (1 green and 1 black)
 - 2x3 ways
 - XWEB500D**
 - 2x2 ways (2 green and 1 black)
 - 1x3 ways
 - 1x7 ways
 - XWEB500B**
 - 2x7 ways
 - 1x3 ways
- 1 2-way jumper



If any of the following components are damaged, do not hesitate to contact your dealer.

You may also receive a modem or a wifi-dongle, which will not be included in the package itself, as an option. When using a connection through the modem, always make sure that the type of modem you are about to install is a Copeland Controls-approved model as they will not be held responsible for the poor operation of devices that are not expressly approved.

4. TECHNICAL FEATURES

	XWEB300D / 500D	XWEB500B
Dimensions	175 x 110 x 41 mm	230 x 210 x 87 mm
Mounting	DIN rail	Wall and panel mounting
Degree of protection	Indoor use, Open Type (NEMA - UL 50e) IP20 (EN60529)	Indoor use, Open Type
Power supply	100-240VAC ±10%	230V
Power supply frequency	50/60 Hz	
Overvoltage category	II	
Rated power	15VA Max	20VA Max
Rated impulse voltage	2500V	
Protection fuse	15A	
Type of action	1.B	
Pollution degree	2	
Temperature operating conditions	-20T60°C	0-60°C, R.H. 20-85% (non-condensing)
Shipping and storage temperature	-40T85°C	
Useful instrument connection data	The serial line cable can be 2-wire plus shielding, with a minimum gauge of 0.5 sq mm (ex. BELDEN 8772).	
Internal battery and RTC accuracy	Rechargeable, non-removable lithium battery. 50ppm for temperature variation up to 60°C, 5ppm for ageing. The maximum clock drift in a year is therefore 33 min per year	
Digital Inputs	Opto-isolated with +12Vdc common (isolated), connectable via 2-way terminal block. Only on XWEB500D	1 dry digital input (free contact)
Digital outputs	AUX1-2-3 dry contacts for 24/120/240Vac max 5A resistive loads. AUX1 ('System Alarm') port in changeover; connectable via 3-way terminal block; always present. AUX2 ('Alarm 1') and AUX3 ('Alarm 2') ports connectable via 2-way terminal block; only available for XWEB500D. Pwr Ext Modem' Output 12Vdc max 250mA connectable via 2-way terminal block; always present	4 digital outputs (1x changeover, 3x normally open). Dry contact outputs. Maximum current (for each relay): 5A Power Ext Modem dry contacts: 12Vdc
RS485 ports	RS485 port 1: opto-isolated (always present) RS485 port 2: opto-isolated (only for XWEB500D)	RS485 port 1: opto-isolated RS485 port 2: opto-isolated
USB ports	1 standard HOST port Type A connector Maximum deliverable current 500 mA	2 standard HOST ports Type A connector Maximum deliverable current 250 mA per port
Purpose of control	Operational controller	
Construction of control	Stand-alone device	
Approvals	CE, UL. The system consisting of this control and monitoring unit and Copeland Controls temperature gauges conforming to EN13485 complies with EC Regulation No. 37/2005 and in particular with EN12830. Temperature recorders for the transport, storage and distribution of chilled, frozen, deep-frozen products (UNI EN 12830, S, A, 1, measuring range corresponding to the class of connected devices)	EC. The system consisting of this control and monitoring unit and Copeland Controls temperature gauges conforming to EN13485 complies with EC Regulation No. 37/2005 and in particular with EN12830. Temperature recorders for the transport, storage and distribution of chilled, frozen, deep-frozen products (UNI EN 12830, S, A, 1, measuring range corresponding to the class of connected devices)

CAUTION:



For all models, the relay connection terminal block can be used to directly drive 230V loads, but the voltages between the different terminals cannot be mixed.

5. INSTALLATION

For installation, the XWEB system must not be opened in any way (XWEB300D/500D). If the box is opened, the warranty lapses. It can be installed in various ways based on the model and type of user interface access that you wish to provide for the final user. The particularities of these types of connectivity are described in this manual.

WARNING: in order to protect both yourself and XWEB, the unit should only be switched on when all electrical devices have already been connected. In order to avoid accidental switch-on, only plug in the power supply cable after all other external units have been connected.



- Use XWEB only with a mains supply and with equipment that complies with all applicable standards. A short-circuit in the mains or in any device connected to XWEB may damage XWEB itself;
- Connection errors (and connections other than those prescribed) can endanger the safety of the operator and cause faults in the system and the instruments connected to it;
- Do not connect XWEB to devices that exceed the maximum load indicated
- Insert one or more easily accessible disconnection devices outside the device to separate the device from the power supply;
- Do not use the device in environments with flammable gases.
- Do not modify the device in any way.

5.1 INSTALL XWEB300D / 500D

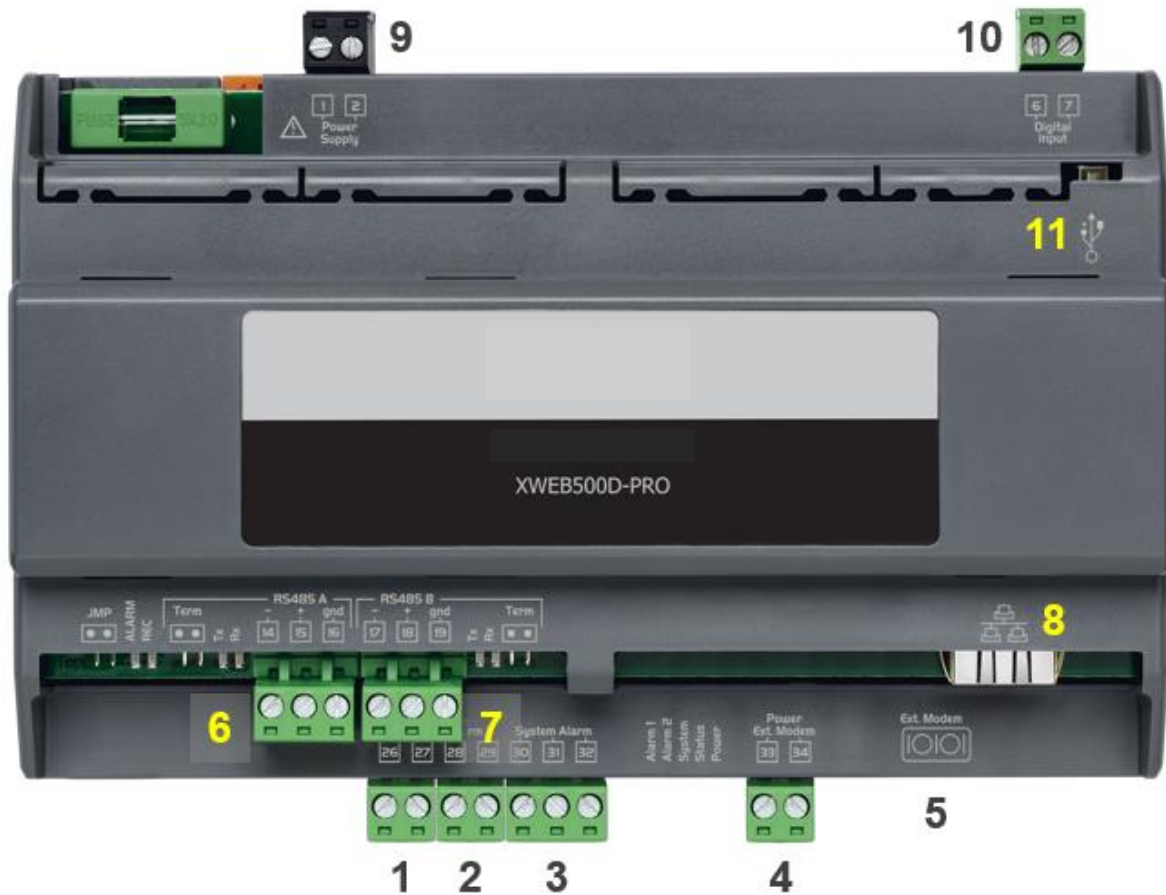

TERMINAL BLOCK

Terminals	Description	Terminals	Description
26 27	(1) Alarm relay 1 (**)	1 2	(9) XWEB power supply
28 29	(2) Alarm relay 2 (**)	33 34	(4) External GSM modem power supply (*) 33 [-]; 34 [+]
30 31 32	(3) System alarm relay 30-31 Normally Open 30-32 Normally Closed		(11) USB for external peripherals
6 7	(10) Digital input (**)		(5) COM for external modem
14 15 16	(6) RS485 A		(8) RJ45 LAN network connector
17 18 19	(7) RS485B (**)		

(*)= 12Vdc - 250mA. The list of supported modems is available online

(**)= only for XWEB500

5.1.1 LED

Led	Colour	Description
Alarm	Red	Alarm on RS485 line
Rec	Blue	System in data recording
Power	Green	System on
Status	Green	Sending message/event queue
System	Red	System alarm
Alarm1	Red	Status of relay output 1 (*)
Alarm2	Red	Status of relay output 2 (*)

(*)= Only for XWEB500D

CAUTION: the status of the System LED is linked to that of the corresponding relay 'System alarm (3)'

CAUTION: for XWEB300D the 'system relay' as AUX assumes the following logic:

- at rest (XWEB off) contacts 30-32 are closed
- in the event of an alarm it closes on 30-31
- when switching on for a few seconds it closes on 30-31. Then if there are no alarms it goes back to rest and closes on 30-32.

CAUTION: for XWEB500D the system alarm relay works safely with the following logic:

XWEB500B	Contact 30-31	Contact 30-32
Off	Open	Closed
On, enabled, no alarms	Closed	Open
On, enabled, in system alarm	Open	Closed
On, disabled	Closed	Open

If there is a system alarm at switch-on, contact 30-31 will close for a few seconds during the start-up phase and then reopen.

CAUTION XWEB500D: preferably use the external modem power supply from the XWEB itself to ensure the correct sending of SMS messages. Use the cable supplied in the modem kit on terminals 33 [-]; 34 [+].

CAUTION: During the initial power-up phase, the ALARM, REC, SYSTE and POWER LEDs light up steady for about 45 seconds.

5.2 INSTALLING XWEB500B



Terminals	Description	Terminals	Description
1 2	(1) Alarm relay 1	RS485 + gnd	(9) RS485 B
3 4	(2) Alarm relay 2		(11) XWEB power supply
5 6 7	(3) System alarm relay 5-6 Normally open 5-7 Normally closed		(8) 2 x USB for external peripherals
8 9	(4) Modem reset relay		(10) COM for external modem
10 11	(5) Digital input		(7) RJ45 LAN network connector
12 13 14	(6) RS485 A		

5.2.1 LED

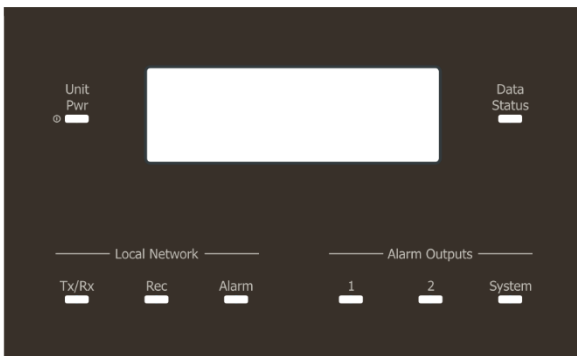

Led	Colour	Description
Unit Power	Green	System on
TX/RX	Red	Serial communication CAUTION ONLY SERIAL A (6)
Rec	Blue	System in data recording
Alarm	Red	Alarm on RS485 line
Alarm Output 1	Red	Status of relay output 1
Alarm Output 2	Red	Status of relay output 2
System	Red	System alarm
Data Status	Green	Sending message/event queue

CAUTION: the status of the System LED is linked to that of the corresponding 'System alarm' relay

CAUTION: for XWEB500B the system alarm relay works safely with the following logic:

XWEB500B	Contact 5-7	Contact 5-6
Off	Open	Closed
On, enabled, no alarms	Closed	Open
On, enabled, in system alarm	Open	Closed
On, disabled	Closed	Open

If there is a system alarm at switch-on, contact 5-7 will close for a few seconds during the start-up phase and then reopen.

CAUTION: supply the external modem via terminals 8-9 of XWEB to ensure that SMS messages are sent correctly. The 'reset modem' relay is energised for reset, in idle status every two minutes and before each service activation.

CAUTION: During the initial power-up phase, the STATUS, REC and ALARM LEDs BLINK at regular intervals. This flashing is NORMAL and highlights the regular progress of the ignition phase, which can last up to 5 minutes.

5.3 CONNECT THE DEVICES

XWEB has at least one RS485 serial port, that the controller device line can be connected to. If there is more than one serial line, more than one device line can be served.

Most Copeland Controls controllers are equipped with an RS485 serial output and can be connected without the need for any additional module or connection cable. To ascertain this possibility, check the controller's features in its manual.

Some Copeland Controls devices, however, may not be so in direct form, but can be obtained via the small Copeland Controls XJRS485 or Copeland Controls XJ485 external converter. The controller output is converted from 'TTL' (five-wire) to '485' (two-wire). If you need to use the TTL/485 converter, pay attention in the:

- Keep the TTL cable away from any source of electromagnetic interference
- Connect each XJ485 module to the instrument with the TTL cable supplied with the module
- Mark the polarity of the 485 output to be observed when connecting the instruments to the network

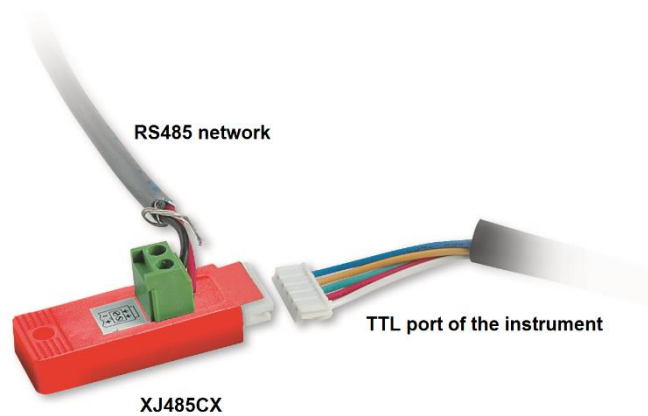

Below is a list of operational tips to achieve the best result in terms of instrument network reliability, RS485 serial connection:

- The serial line cable can be 2-wire plus shielding, with a minimum gauge of 0.5 sq mm (ex. BELDEN 8772). This cable is recommended for its technical characteristics and for maintaining the quality of the electrical signal;
 - The serial line cable must reach all locations on the instrument: check the plant layout and the various distances the cable must travel;
 - The serial line cable can reach a maximum length of 1 km
 - Respect the polarities indicated on the instrument with those of the wires of the cable leading to the serial
 - Keep the serial cable away from power cables and any possible source of electromagnetic interference
 - Connect the shield of the serial cable to the earth of the electrical system at one point.
 - Do not connect the 'Gnd' terminals.
 - Draw a map of the installation you are setting up: this will be useful both in the event of problems and in the event of future modifications; the serial line must reach all the locations where the instruments are to be controlled.
- Do not branch out into the line:



Correct connection

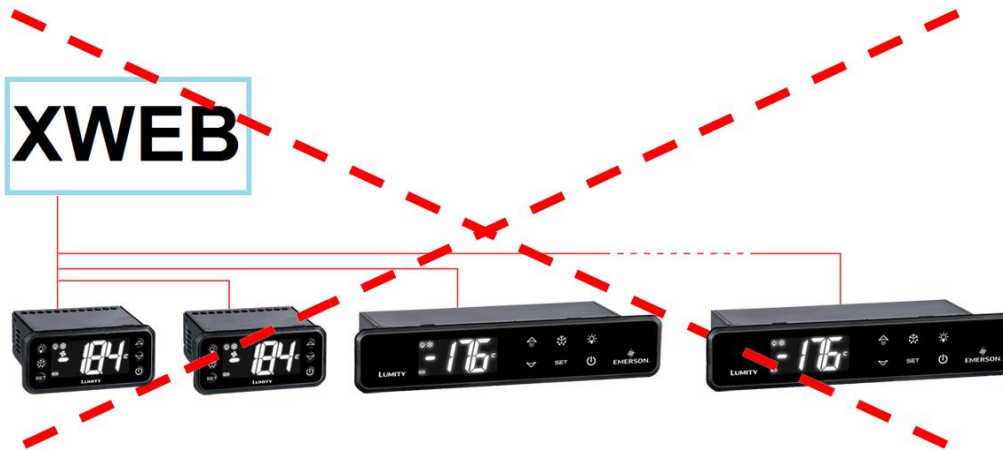

Incorrect connection

On the same line, each controller must be programmed with its own **unique serial address**, via the **Adr** parameter. Refer to the installation manual of the instrument itself for the access and modification procedure. In order to obtain a simple description of the categories that they belong to, subdivide the address programming in a progressive manner. Some special cases are listed on the following pages.

Terminating resistors of 120Ω are useful in lines longer than 50 metres with widely spaced devices. Placing XWEB at one end of the RS485 line, the 120Ω termination resistor should be inserted between the + and - of the RS485 terminal of the last instrument, at the opposite end of the line. In this case, activate XWEB's end-of-line resistor by inserting the jumper on the TERM of the relevant serial (XWEB300D/500D), i.e., set the TERM microswitch of serial 1 or 2 to the ON position. DO NOT insert the jumper/microswitch if the XWEB is in the middle of the RS485 line.

5.3.1 XC400/600/800/900 AND XH200/300/400 SERIES CONFIGURATION

These instruments have two serial addresses and must be configured identically. Refer to the installation manual of the instrument itself for the access and modification procedure.

5.3.2 CONFIGURATION OF MODELS XJA/XJP/XJM

The XJA/XJP/XJM series of instruments can be configured with one or more modbus addresses. Refer to their installation manual for configuration procedures.

6. REMOTE CONNECTIVITY



The user can access the web user interface from a properly connected and configured PC or equivalent device. The use of a PC or at least a high-resolution graphics terminal is recommended for the first configuration.

The terminal used must comply with and support the minimum features for the installation and use of the following software.

6.1 DESKTOP SOFTWARE REQUIREMENTS (PC)

Browser	Support	Minimum Version
Microsoft Edge	SUPPORTED	16+
Mozilla Firefox	SUPPORTED	54+
Google Chrome	SUPPORTED	58+
Apple Safari	SUPPORTED	10.1+

Opera	SUPPORTED	44+
Microsoft Internet Explorer	NOT SUPPORTED	

6.2 MOBILE SOFTWARE REQUIREMENTS (SMARTPHONE/TABLET)

Browser	Support	Minimum Version
Apple iOS Safari	SUPPORTED	10.3+
Android Google Chrome	SUPPORTED	58+
Android Mozilla Firefox	SUPPORTED	54+

All newer computers are capable of meeting these requirements. However, it is advisable to seek the advice of an IT expert when evaluating computers to be purchased and/or already in your possession.

In the following sections, general information on possible network configurations will be given. From the outset, we recommend that you engage the services of IT experts and/or your network administrator to evaluate the configurations best suited to your needs.

Softwares such as antivirus, firewalls, toolbars may prevent the correct display of XWEB pages. We advise you to check the configuration of these softwares and add the IP address of XWEB to their list of safe sites, if any. **For firewalls, ensure that ports 443 (https) and 22 (ssh) are mapped to XWEB so that it can be reached from the outside.**

6.3 CROSS-CABLE CONNECTIVITY

Local access from the PC is the fastest way to manage the setup. A PC can be connected to XWEB via the network interface supplied with the 'RJ45 Ethernet connector'. The connection between the two is to be made by means of a crossed network cable (aka 'cross cable'). Such a cable is available in any computer shop. After the physical connection, launch the browser of your PC and enter <https://192.168.0.150> (default address of XWEB 300/500) in the address bar. The display of the start page (login) will complete the connection procedure. Enter your user name and password to start using your XWEB.

Caution: a prerequisite for a successful connection is IP class compatibility between the address of XWEB and that of your PC's network interface. For example, with the XWEB network interface configured to 192.168.0.200, your PC's network interface can be configured to 192.168.0.15

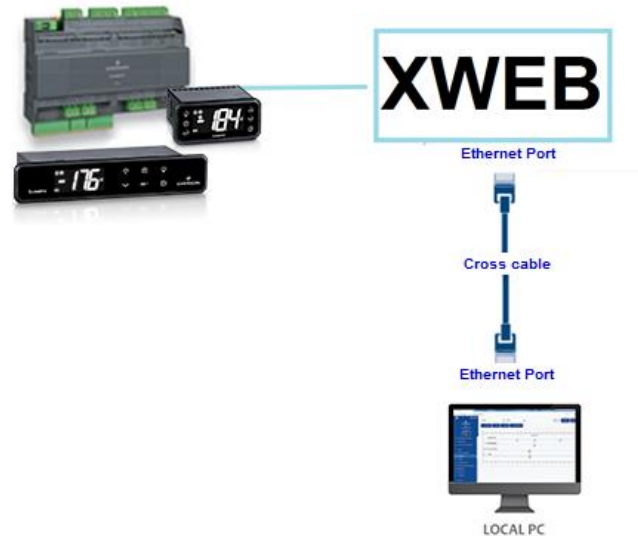

Administration privileges are normally required to configure the network interface of your PC. Refer to the documentation of your PC's operating system. The following figure shows the steps to be taken to configure the network interface of a PC running WINDOWS.

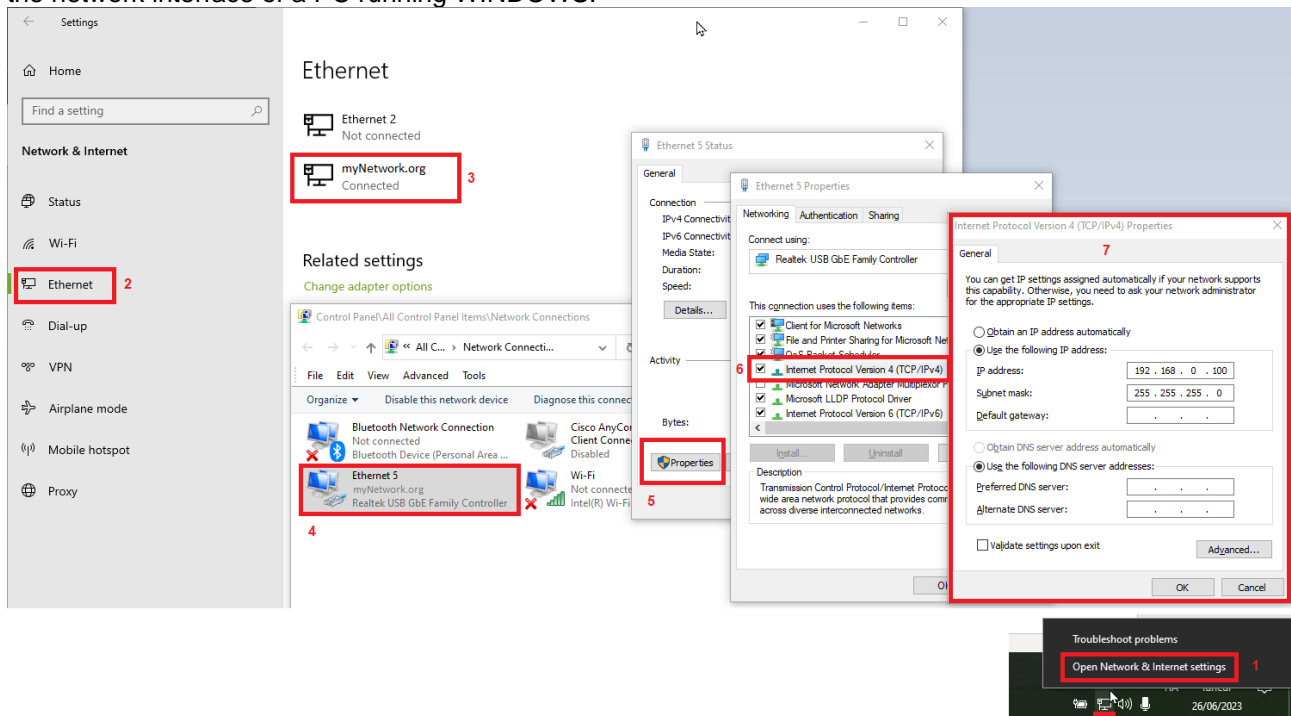

6.4 INTRANET CONNECTIVITY (LAN CONNECTION) AND VPN

This type of connection will allow you to access XWEB from any PC connected to the local network. This type of connection must also be used to configure XWEB for connection from the Internet via VPN (Virtual Private Network). The latter type of connection, once established, brings your PC -- connected to the Internet -- into the XWEB local network.

Caution: the connection to your company's local network is supposed to be managed by qualified personnel and/or the network administrator. They must be able to assign a valid IP address to XWEB and be able to provide -- for your PC -- any software and credentials if you wish to use a VPN network for access.

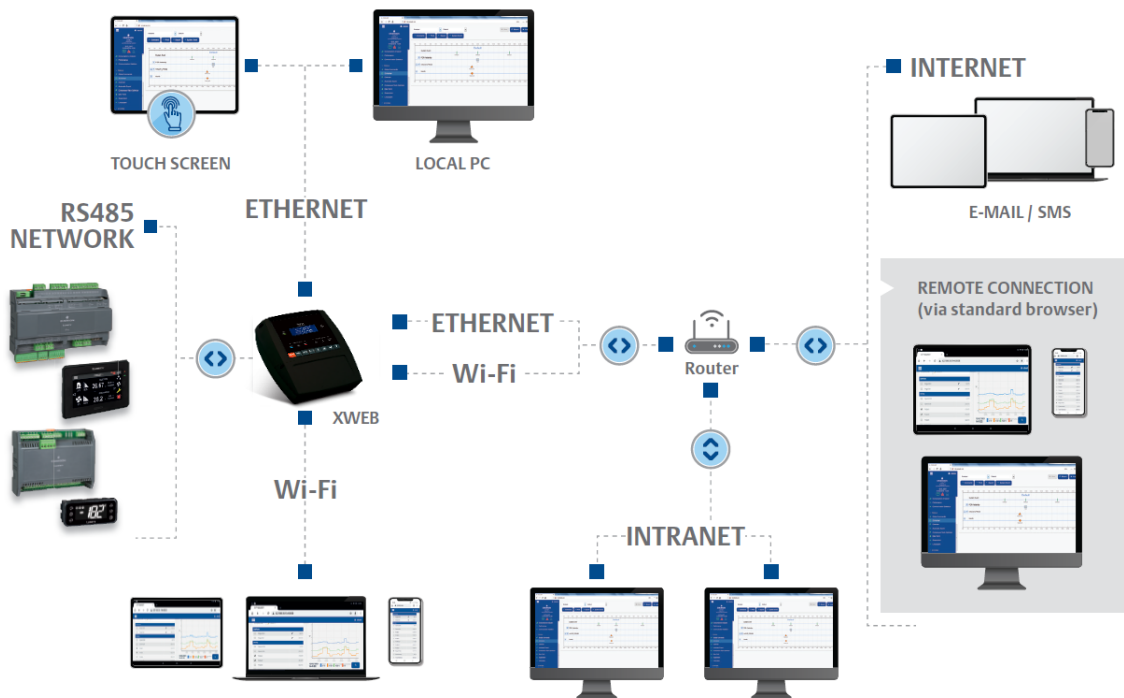

Before connecting XWEB to the network, check that the IP address you wish to use for XWEB is actually free and therefore usable. You could execute a PING command to that address and if PING receives at least one reply, the address should be changed as it is already in use.

Example:

```

C:\Windows\system32\cmd.exe

C:\>ping 10.100.82.201 <-- command to verify the IP address

Pinging 10.100.82.201 with 32 bytes of data:
Reply from 10.100.82.201: bytes=32 time=34ms TTL=62
Reply from 10.100.82.201: bytes=32 time<1ms TTL=62
Reply from 10.100.82.201: bytes=32 time<1ms TTL=62
Reply from 10.100.82.201: bytes=32 time<1ms TTL=62
Ping statistics for 10.100.82.201:
    Packets: Sent = 4, Received = 4, Lost = 0 (0% loss),
    Approximate round trip times in milli-seconds:
        Minimum = 0ms, Maximum = 34ms, Average = 8ms

C:\>_
    
```

with a reply the IP address is already used, you need to set up your new xweb with another IP address !

Before connecting the XWEB to the Ethernet network, configure its IP and other network parameters via a PC connected directly with a crossover Ethernet cable or via the LCD display (XWEB500B). Once the network parameters have been set, XWEB can be connected to the local network with a standard RJ45 cable. Connect

to XWEB from your PC by opening your browser and entering the IP address of XWEB in the address bar. The default address is: <https://192.168.0.150> . Store the address in the list of favourites.

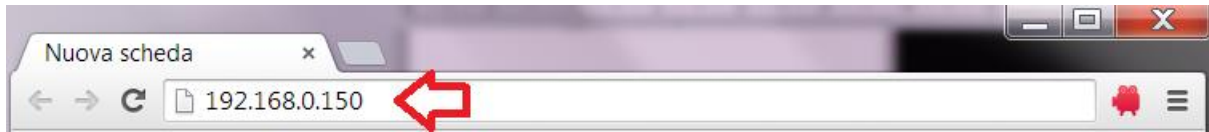

6.5 INTERNET CONNECTIVITY ON PUBLIC IP

This type of connection will allow you to access XWEB directly from any PC connected to the Internet without having to install - on your PC - any additional software.



Caution: the connection to the Internet is supposed to be managed by qualified personnel and/or the network administrator.



In order to connect your XWEB to the Internet, you need a **'public, static IP address'**, which **must be expressly requested from your ISP** (Internet Service Provider). Indicate to your ISP that you want to install a webserver: this will help them recognise your needs and provide you with a suitable connection. It is highly recommended to be provided with all the details of the supply contract for the handling of any future connection problems.

The internet connection is possible with a router. Its configuration, as well as that of XWEB, depends on the data provided by your ISP. Depending on the type of contract, the provider may provide the Router or the customer may purchase it separately.

Provide your ISP and/or network administrator with the XWEB ports (LAN side)

- 443 (used for HTTPS access)
- 22 (used for SSH access)

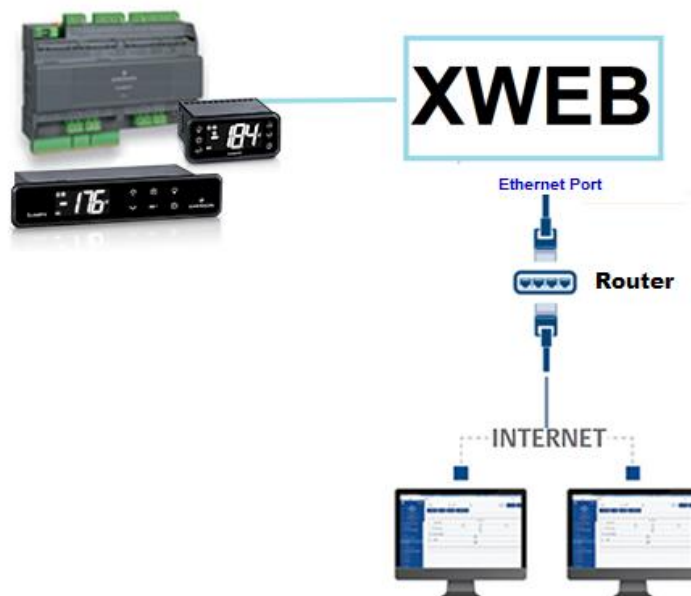

6.6 WIFI CONNECTIVITY

This type of connection will allow you to access XWEB directly from a device equipped with a wifi connection, or to have XWEB access an already configured wifi network. Prerequisite to these types of connectivity is the installation of the WIFI dongle in the XWEB USB port.

CAUTION: only use dongles officially supported by this monitoring unit.

Connecting a mobile device to the XWEB accesspoint

XWEB is normally supplied pre-configured in this mode so that the user can search for an SSID 'XWEB-PRO' network with their PC/smartphone/tablet. The default password is 'dixellxwebpro'.

Fixed IP address 172.21.0.1

USB Wi-Fi Adapter	
Mode	<input type="text" value="Access Point"/>
SSID	<input type="text" value="XWEB-PRO"/>
Password	<input type="text" value="dixellxwebpro"/>

Connecting XWEB to an existing wifi network

XWEB can be connected via wifi to a Wifi-AccessPoint already present on the site. In this case, it is necessary to temporarily access the xweb interface with another type of connection (typically with a cross-cable) in order to change the configuration parameters to the connection.

USB Wi-Fi Adapter	
Mode	<input type="text" value="Wi-Fi"/>
SSID	<input type="text" value="myNetSSID"/>
Password	<input type="text" value="....."/>
IP Address (leave empty to auto assign)	<input type="text"/>

Changes to the configuration can be made by the user after accessing the user interface from the menu System→Settings→Network.



CAUTION: no access to port 22 service is provided via wifi

7. EMERGENCY PROCEDURE

This procedure allows XWEB to be restored to its factory settings; it is useful in cases where the IP address and/or web service port and/or access credentials (username/password) have been lost and/or there are generic errors. The procedure is applicable with XWEB software versions 5.0 and higher.

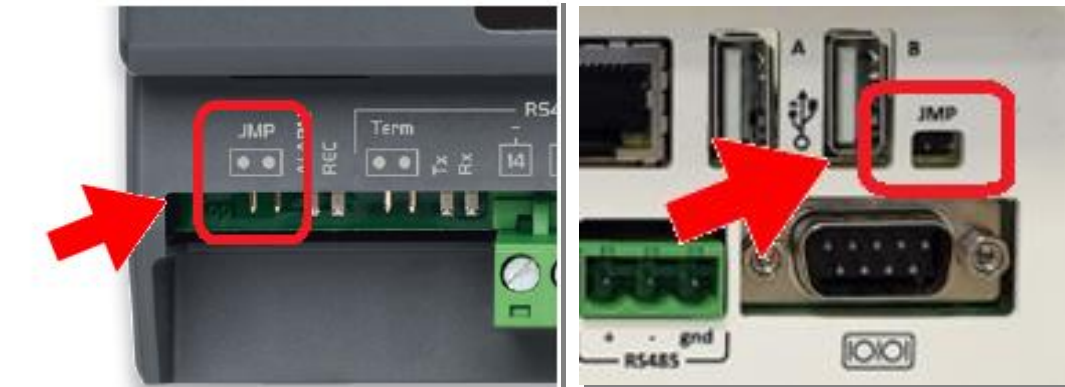
- 1) With the instrument switched off, close the 'JMP' contacts using the jumper supplied with the XWEB product



- 2) Connect a network cable between XWEB and PC
- 3) Configure the PC's network interface with address 192.168.0.6 or compatible class;
- 4) Switch on XWEB and wait a couple of minutes
- 5) With your browser (Firefox  or Chrome ) open the address <http://192.168.0.150>

You will be presented with a page like the one in the image below where you will see:

- a. **MAC Address:** alphanumeric code identifying XWEB
- b. **IP Address:** IP address operating outside the emergency procedure
- c. **HTTP / HTTPS Port:** web services ports operating outside the emergency procedure
- d. **DATE:** system date

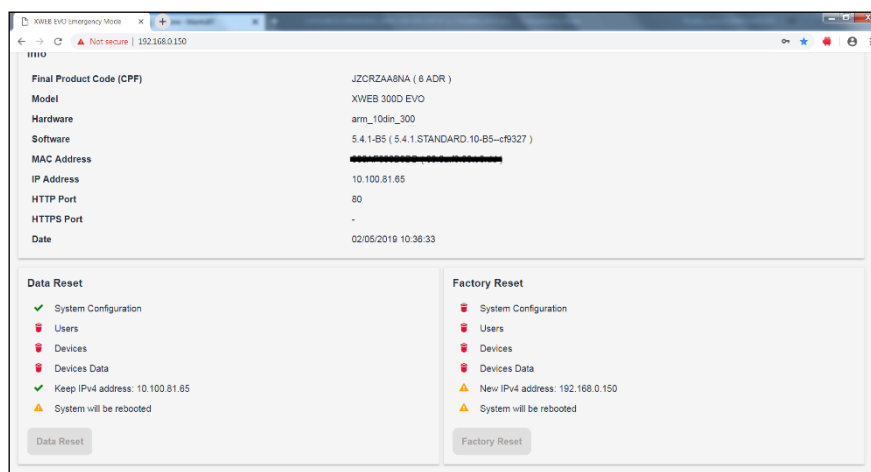

In case you only want to retrieve the IP, you can interrupt the procedure by opening the JMP contacts and restarting XWEB by acting on its power supply.

Instead, to complete the emergency procedure and reset the user configuration and configured field devices, proceed as described below. **Caution:** all historical data (such as temperatures) will also be lost; software updates and/or libraries will remain installed. The reset operation is not reversible and lost data will not be recoverable from XWEB.

- 6) Click on **FACTORY RESET** for a reset of the system parameters including the network configuration; with this option the system will become reachable outside the emergency procedure only on IP:192.168.0.150
Click on **DATA RESET** in order not to lose the network configuration (and other system configuration parameters); the system will then be reachable outside the emergency procedure with the IP of 'IP ADDRESS' on the page described in the previous section.
- 7) Open the JMP contacts by removing the jumper
- 8) Enter the credentials provided by Copeland Controls S.r.l. Technical Support who was given the XWEB MAC ADDRESS and DATA

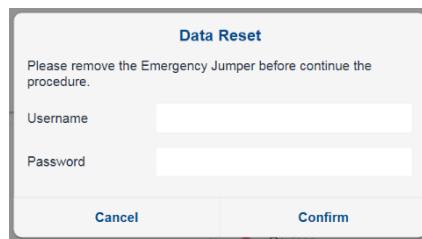

Data Reset

Please remove the Emergency Jumper before continue the procedure.

Username

Password

- 9) Press the 'Confirm' button: if the data entered is correct, the system will complete its operations and be restarted automatically. Caution: do not disconnect the power supply until xweb has restarted completely.
- 10) Wait a couple of minutes for the emergency procedure to complete; you will now be able to log in with your username and password: Admin/Admin

8. OPERATIVITY

For operational procedures, refer to the OPERATIONAL MANUAL available on the Copeland website.



CONTACT: dixell.service@copeland.com

9. SYSTEM DATA

Fill in the table below, make a photocopy and keep it close to XWEB.

HostName _____ [example: myXWEB001]

IP Address _____ [example: 192.168.0.123]

Gateway _____ [example: 192.168.0.1]

DNS _____ [example: 8.8.8.8]

SMTP _____ [example: 192.168.0.14]

E-mail address _____ [example: myXWEB001@company.com]

Telephone number _____

10. TRADEMARKS

Windows and Internet Explorer are registered trademarks of Microsoft Corporation in the United States and other countries.

Google is a registered trademark of Google Inc.

Firefox is a registered trademark of the Mozilla Foundation.

Yahoo! is a registered trademark of Yahoo! Inc.

Linux is a trademark registered to Linus Torvalds.

Other names may be trademarks of their respective owners.

11. NOTES

COPELAND

Copeland Controls S.r.l.
Z.I. Via dell'Industria, 27 - 32016 Alpago (BL) ITALY
Tel. +39 0437 9833 r.a. - copeland.com - dixell@copeland.com