

Diameter:

630 mm

R13_-6330H_-6T2-7042



Fan with guard grill

Airflow Direction	Type	Code	Weight (kg)
Sucking	R13R-6330HA-6T2-7042	0313-4-1000	14.5
Blowing	R13R-6330HP-6T2-7042	0313-4-1017	

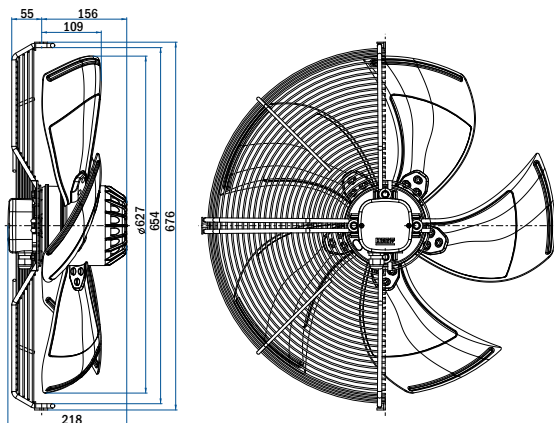

Fan with plate

Airflow Direction	Type	Code	Weight (kg)
Sucking	R13P-6330HA-6T2-7042	0313-4-1013	23.3
Blowing	R13P-6330HP-6T2-7042	0313-4-1019	

Fan without guard grill

Airflow Direction	Type	Code	Weight (kg)
Sucking	R13E-6330HA-6T2-7042	0313-4-1042	10.8
Blowing	R13E-6330HP-6T2-7042	0313-4-1050	

Nominal data according to standard EN 60335:	
Phase	3~
Nominal voltage	400 V
Frequency	50 Hz
Speed	high/low
Rated power input	600/380 W
Rated current	1.25/0.65 A
Rated speed	870/640 RPM
Min. ambient temperature	-30 °C
Max. ambient temperature	40 °C
Sound power level A weighted	77/73 dB (A)
Connection	terminal box
Insulation class	155
Protection class	IP54

ErP data according to EU regulation 327/2011:	
Overall efficiency	32.7 %
Measurement category	A
Efficiency category	static
Efficiency grade N	40.1
Variable speed drive	NO
Power input	680 W
Air flow	7593 m ³ /h
Pressure drop	107 Pa
Speed	877 RPM
Specific ratio	1.00

Aerodynamic characteristic

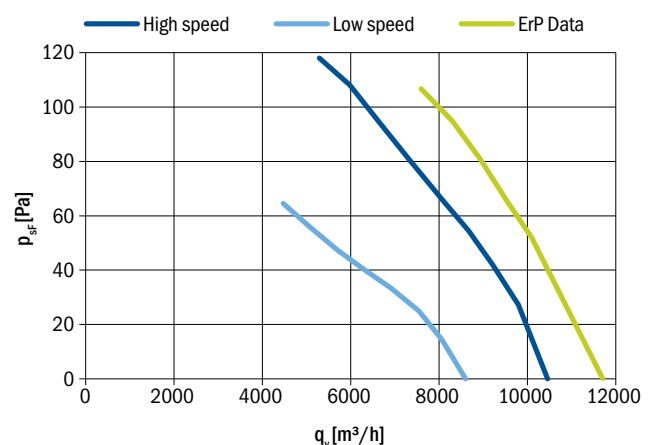

Fan characteristic measured in full bell mouth with guard grill.
ErP characteristic measured in full bell mouth without guard grill.

General notes	
Connection diagrams:	
Sucking	0301-1-0033 See section
Blowing	0301-1-0033 Connection diagrams
Guard grills & wall-plates	See section Accessories
Standards compliance	See introduction page