



**ZANOTTI Spa**  
 Via M.L. King, 30  
 46020 - Pegognaga (MN) - ITALY  
 Tel. +39 0376 5551  
 Fax +39 0376 536554  
 info@zanotti.com

# Technical specifications

Version 1.48

Model:

Class:

**BGM218DA11XA**

**Uniblock GM**

## Technical data

Characteristics	M.U.	Value
Working temperature	°C	-15 ÷ -25
Starting mode		Direct
Voltage	Volt-Ph-Hz	230/1/50
Rated input	kW*	1,10
Rated input	Amp*	6,40
Peak current	Amp	44,0
Max current	Amp	11,7
Refrigerant		R452A
	GWP	2140
Defrost		Hot gas
Mass	Kg	80

## Compressor

Type		Hermetic
Nominal power	kW	1,3

## Condenser

Air flow	m³/h	1200
----------	------	------

## Evaporator

Air flow	m³/h	1200
Air throw	m**	4

PED Category		0
--------------	--	---



## Power data

Tc °C	Ta °C	P watt	P Kcal/h	V120 m³	V100 m³	V80 m³
	20	1925	1656	17	15	13
	25	1809	1556	17	15	13
-15	30	1703	1465	15	13	12
	35	1597	1373	14	12	11
	40	1481	1274	12	11	9,4
	45	1345	1157	10	8,9	7,8
	20	1635	1406	14	12	11
	25	1527	1313	13	12	10
-20	30	1429	1229	12	11	9,4
	35	1336	1149	10	8,9	7,8
	40	1243	1069	9,1	8,1	7,1
	45	1144	984	7,9	7	6,2
	20	1353	1164	11	9,8	8,6
	25	1265	1088	9,4	8,4	7,3
-25	30	1181	1016	8,4	7,5	6,6
	35	1100	946	7,4	6,6	5,8
	40	1018	875	6,5	5,8	5,1
	45	931	801	5,6	5	4,4

\* When normally running: -20 ÷ +30°C

\*\* Use air throw as a base. Air throw is affected by many factors such as height of room, product storage, location of evaporator, etc.

Tc: Coldroom temp. - Ta: External temp.

P: Refrigerant capacity - V: Recommended cold-room volume

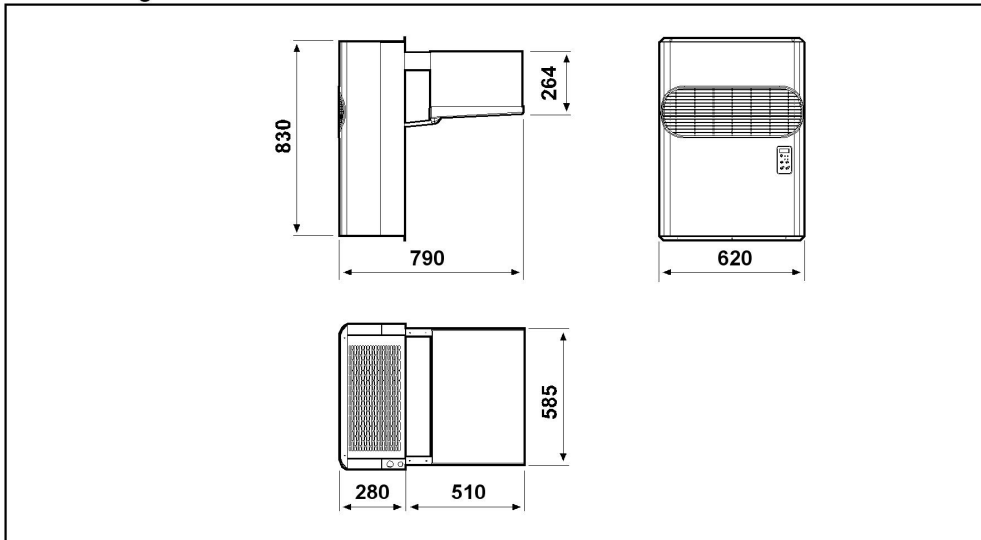

Schema di montaggio - Mounting scheme - Schema de montage  
Montageschema - Esquema de montaje

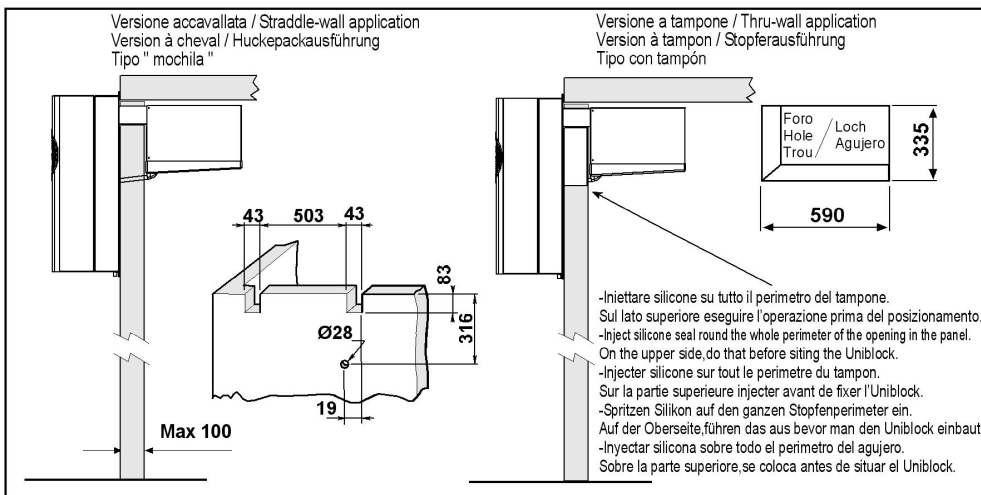

- \* Raccomandazioni in sede di installazione e per il controllo fornite sul manuale di installazione
- \* To be advised at time of order for factory installation and operating instructions
- \* Recommendations au moments d'installations et pour le contrôle fournis sur le manuel d'installation
- \* Empfehlungen für die Installationsphase und zur Kontrolle, die im Handbuch zur Installation enthalten sind
- \* Por cuanto respecta a recomendaciones de instalaciòn y control ver manual de instalaciòn

Massa e misure imballi - Packing mass and dimensions - Masse et dimensions emballages  
Verpackungsmasse und-abmessungen - Masa y medidas del embalaje

