



ZANOTTI Spa
 Via M.L. King, 30
 46020 - Pegognaga (MN) - ITALY
 Tel. +39 0376 5551
 Fax +39 0376 536554
 info@zanotti.com

Technical specifications

Version 1.48

Model:

Class:

BGM320DB11XA

Uniblock GM

Technical data

Characteristics	M.U.	Value
Working temperature	°C	-15 ÷ -25
Starting mode		Direct
Voltage	Volt-Ph-Hz	400/3N~/50
Rated input	kW*	2,10
Rated input	Amp*	4,70
Peak current	Amp	28,0
Max current	Amp	9,5
Refrigerant		R452A
	GWP	2140
Defrost		Hot gas
Mass	Kg	105

Compressor

Type		Hermetic
Nominal power	kW	1,5

Condenser

Air flow	m³/h	1500
----------	------	------

Evaporator

Air flow	m³/h	1800
Air throw	m**	10

PED Category		0
--------------	--	---



Power data

Tc °C	Ta °C	P watt	P Kcal/h	V120 m³	V100 m³	V80 m³
	20	3323	2858	45	40	35
	25	3139	2700	41	36	32
-15	30	2918	2509	36	32	28
	35	2672	2298	31	28	24
	40	2416	2078	27	24	21
	45	2162	1859	22	20	17
	20	2849	2450	35	31	27
	25	2684	2308	32	28	25
-20	30	2491	2142	28	25	22
	35	2276	1957	24	21	19
	40	2045	1759	20	18	16
	45	1802	1550	17	15	13
	20	2377	2044	26	23	20
	25	2212	1902	23	20	18
-25	30	2035	1750	19	17	15
	35	1848	1589	17	15	13
	40	1655	1423	15	13	12
	45	1459	1255	12	11	9,4

* When normally running: -20 ÷ +30°C

** Use air throw as a base. Air throw is affected by many factors such as height of room, product storage, location of evaporator, etc.

Tc: Coldroom temp. - Ta: External temp.

P: Refrigerant capacity - V: Recommended cold-room volume

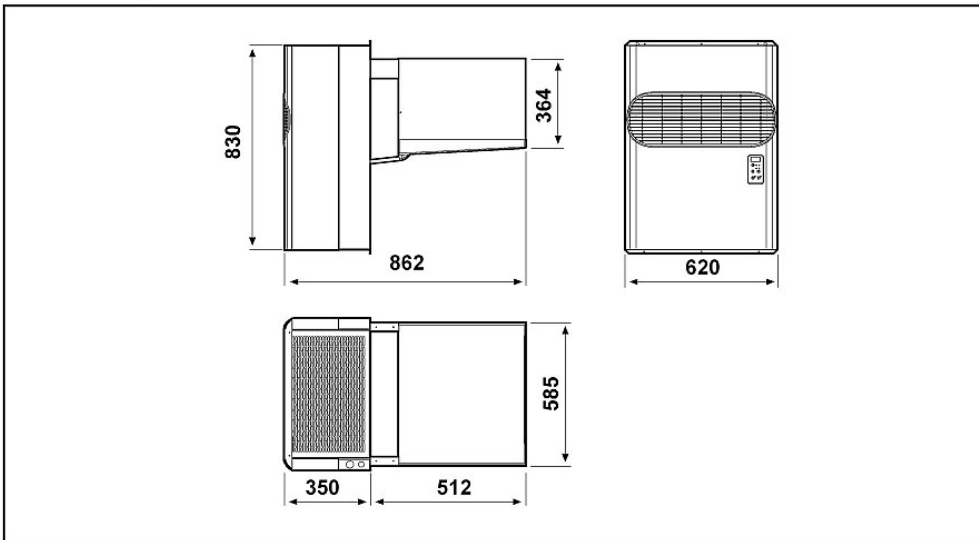

Schema di montaggio - Mounting scheme - Schema de montage
Montageschema - Esquema de montaje

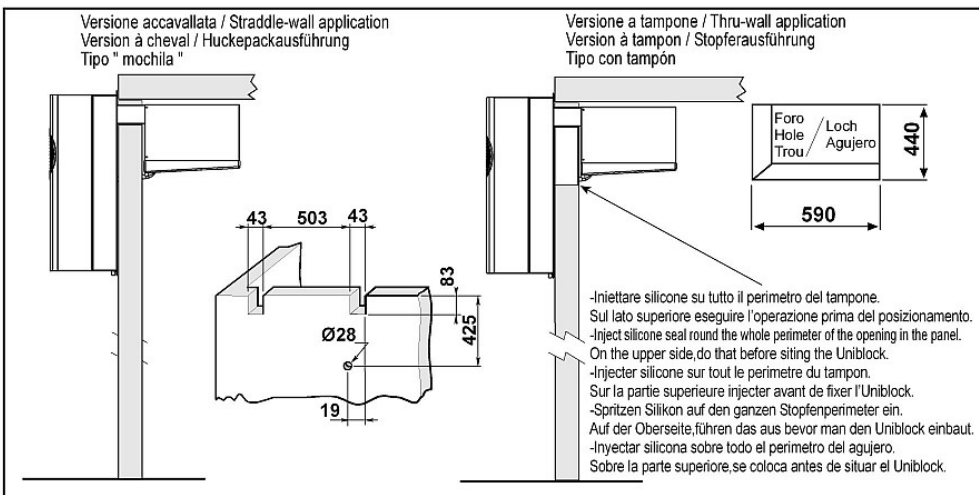

- * Raccomandazioni in sede di installazione e per il controllo fornite sul manuale di installazione
- * To be advised at time of order for factory installation and operating instructions
- * Recommendations au moments d'installations et pour le contrôle fournis sur le manuel d'installation
- * Empfehlungen für die Installationsphase und zur Kontrolle, die im Handbuch zur Installation enthalten sind
- * Por cuanto respecta a recomendaciones de instalación y control ver manual de instalación

Massa e misure imballi - Packing mass and dimensions - Masse et dimensions emballages
Verpackungsmasse und-abmessungen - Masa y medidas del embalaje

