



ZANOTTI Spa
 Via M.L. King, 30
 46020 - Pegognaga (MN) - ITALY
 Tel. +39 0376 5551
 Fax +39 0376 536554
 info@zanotti.com

Technical specifications

Version 1.48

Model:

Class:

BGM340DB11XA

Uniblock GM

Technical data

Characteristics	M.U.	Value
Working temperature	°C	-15 ÷ -25
Starting mode		Direct
Voltage	Volt-Ph-Hz	400/3N~/50
Rated input	kW*	2,20
Rated input	Amp*	5,00
Peak current	Amp	35,0
Max current	Amp	11,4
Refrigerant		R452A
	GWP	2140
Defrost		Hot gas
Mass	Kg	113

Compressor

Type		Hermetic
Nominal power	kW	2,9

Condenser

Air flow	m³/h	2200
----------	------	------

Evaporator

Air flow	m³/h	2100
Air throw	m**	10

PED Category		2
--------------	--	---



Power data

Tc °C	Ta °C	P watt	P Kcal/h	V120 m³	V100 m³	V80 m³
	20	4157	3575	62	55	48
	25	3937	3386	57	51	44
-15	30	3698	3180	52	46	41
	35	3441	2959	47	42	37
	40	3162	2719	41	36	32
	45	2862	2461	35	31	27
	20	3608	3103	50	44	39
	25	3386	2912	46	41	36
-20	30	3160	2718	41	36	32
	35	2922	2513	36	32	28
	40	2663	2290	31	28	24
	45	2375	2042	26	23	20
	20	3065	2636	39	35	30
	25	2847	2448	35	31	27
-25	30	2618	2251	30	27	23
	35	2385	2051	26	23	20
	40	2155	1853	22	20	17
	45	1933	1662	17	15	13

* When normally running: -20 ÷ +30°C

** Use air throw as a base. Air throw is affected by many factors such as height of room, product storage, location of evaporator, etc.

Tc: Coldroom temp. - Ta: External temp.

P: Refrigerant capacity - V: Recommended cold-room volume

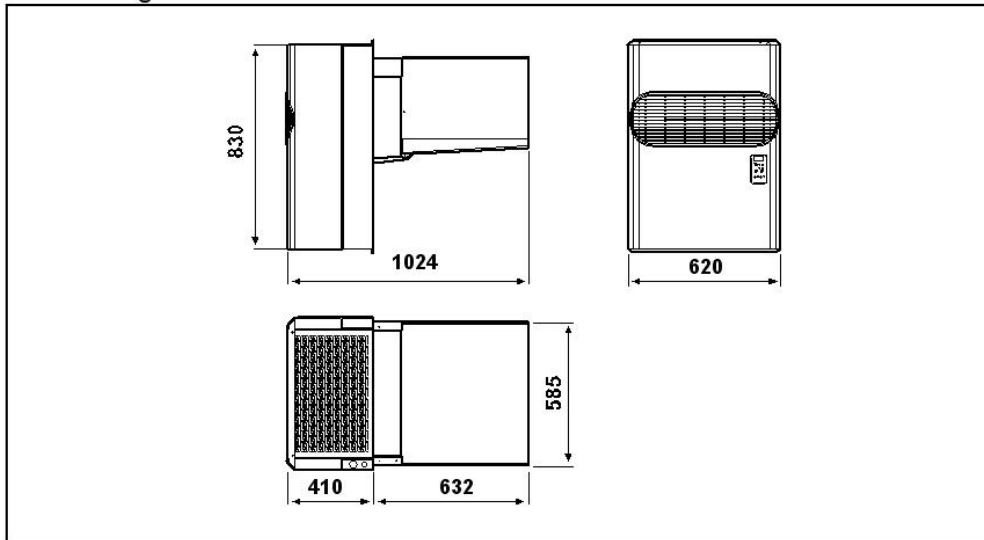

Schema di montaggio - Mounting scheme - Schema de montage
Montageschema - Esquema de montaje

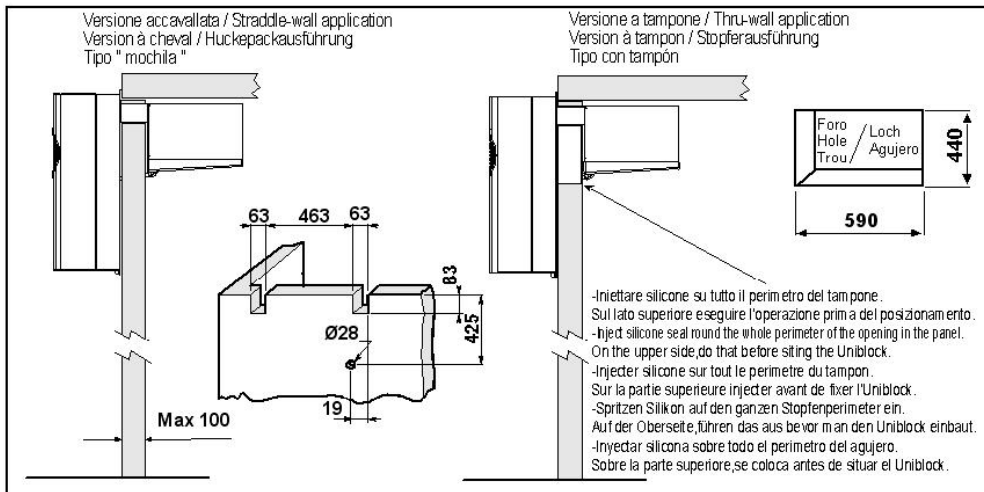

- * Raccomandazioni in sede di installazione e per il controllo fornite sul manuale di installazione
- * To be advised at time of order for factory installation and operating instructions
- * Recommendations au moments d'installations et pour le contrôle fournis sur le manuel d'installation
- * Empfehlungen für die Installationsphase und zur Kontrolle, die im Handbuch zur Installation enthalten sind
- * Por cuanto respecta a recomendaciones de instalación y control ver manual de instalación

Massa e misure imballi - Packing mass and dimensions - Masse et dimensions emballages
Verpackungsmasse und-abmessungen - Masa y medidas del embalaje

