

F.M.I. part number EC156AAB09DAA1 REV01

Customer part number:

S.P.:

Issued: M.Nava

Checked:

Rotazione antioraria lato uscita albero
C.C.W. rotation seen from shaft

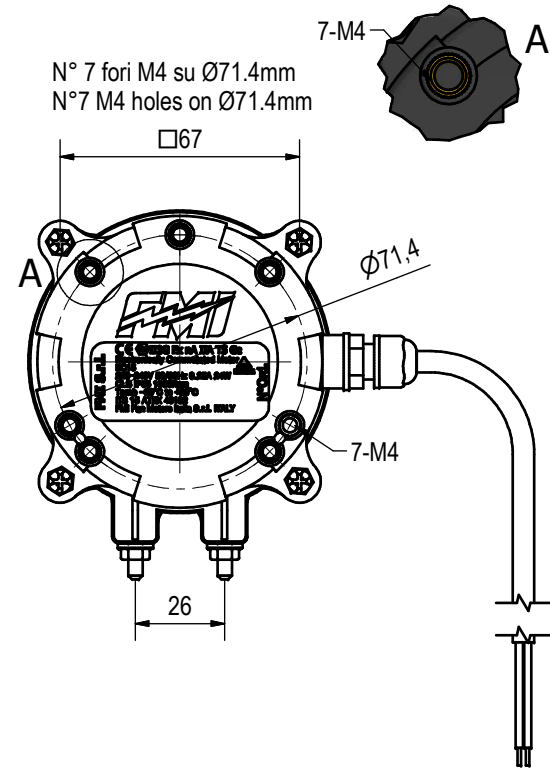
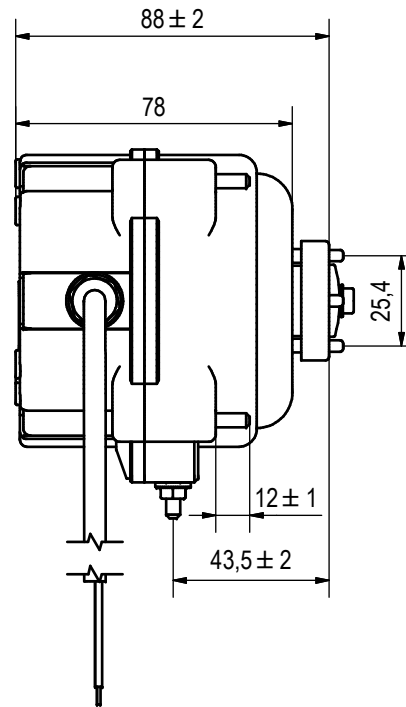
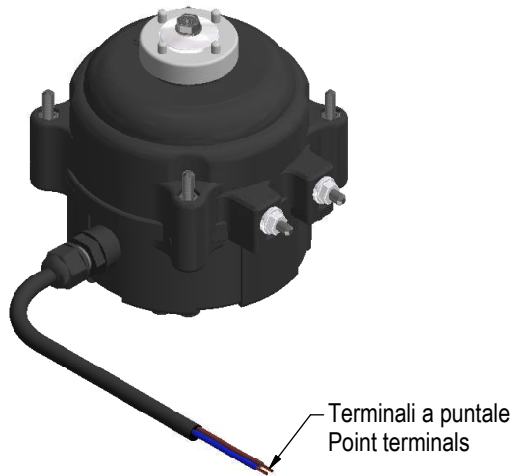
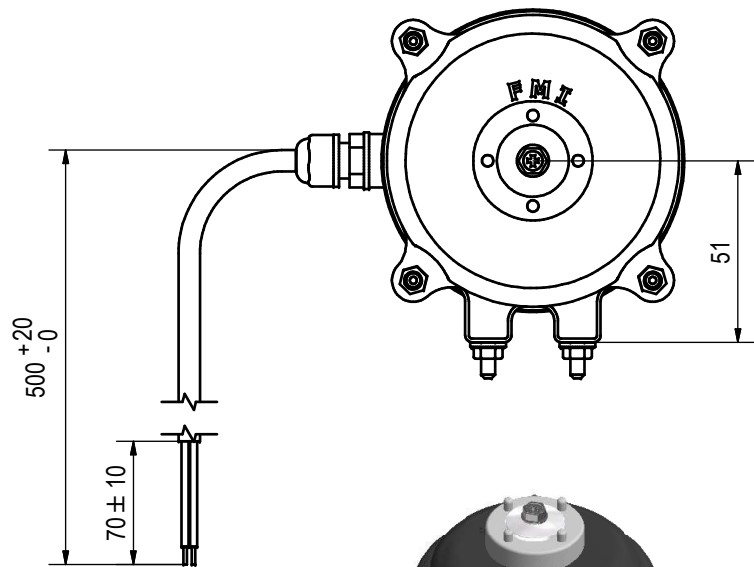

Schema di collegamento
Wire connect

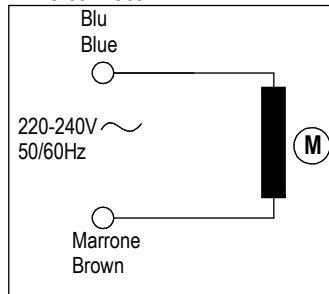

Etichetta dati
Data label

FMI S.p.A. **II3G Ex nA IIA T5 Gc**
Electronically Commutated Motor
EC15
220-240V 50/60Hz 0.25A 24W
Cl.B IP65 1300Rpm
Tamb -30°C to +50°C
ITS 15 ATEX 48182
FMI Fan Motors Italia S.r.l. ITALY

N°Ord.



Issued date: 18/04/2014		
Date	Modification:	Sign.
24/02/2015	Modificata etichetta per ATEX	
21/02/2017	Aggiunti 7 fori sul coperchio posteriore (REV01)	Nava

Customer stamp for acceptance

Note	ELECTRONIC MOTOR 15W IP65
1	1300RPM: fan Ø172mm/22° sucking - Ø230mm/34° sucking
2	Cavo con terminali a puntale - Cable with point terminals
3	Temperatura ambiente: -30°C / +50°C - Ambient temperature: -30°C / +50°C
4	Motore a cuscinetti - Ball bearings motors
5	
6	

This drawing is property of FMI Fan Motors Italia s.r.l.
Total or partial reproduction or transmission to third parties is forbidden without consent.