



Generators F200 to F2000

Contractor's manual

EN0220EN_VO.02_2017-12

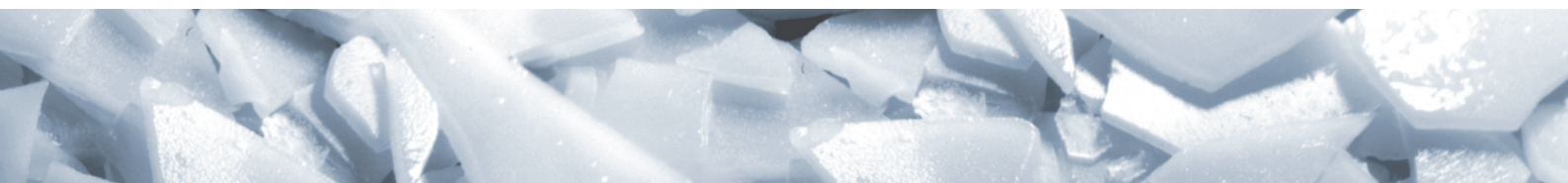



Table of contents

| | |
|---|-----------|
| 1. General | 4 |
| 2. Safety rules | 5 |
| 3. Safety and Environmental Instructions | 6 |
| 4. Safety concerning pressure vessels..... | 7 |
| 5. Handling..... | 8 |
| 6. Dimensions..... | 9 |
| 7. Positioning the machine..... | 10 |
| 8. Connections | 13 |
| 9. Operation | 21 |
| 10. Addition of salt | 31 |
| 11. Initial start up..... | 33 |
| 12. Commissioning Check list | 38 |
| 13. Operational Measurement sheet..... | 40 |
| 14. Troubleshooting | 44 |

| | |
|---|-----------|
| 15. Options..... | 45 |
| 16. Maintenance | 46 |
| 17. Exploded view | 49 |
| 18. Adjustment of Rubber Wipers Blade..... | 53 |
| 19. Adjustment of Reamer..... | 54 |

IDENTIFICATION

| | | | |
|---|--|---|----|
|  | | 9, rue des Orfèvres 44840 Les Sorinières France +33(0)2 51 19 10 51 | |
| Type / Model | | | |
| N° Série construction <i>Construction serial number</i> | | | |
| Année de fabrication <i>Manufacturing year</i> | | Fluide <i>Fluid</i> | |
| Pressions mini/maxi admissibles (PS) <i>Mini/maxi allowable pressures</i> | | Bar | |
| Températures mini/maxi admiss. (TS) <i>Mini/maxi allowable temperatures</i> | | °C | |
| Pression d'épreuve (PT) / <i>Test pressure</i> | | Bar | |
| Date d'épreuve / <i>Test pressure date</i> | | | |
| Groupe de fluide / <i>Fluid group</i> | | | |
| Charge fluide maxi / <i>Maxi refrig. charge</i> | | Kg | |
| Tension – Phase(s) / <i>Voltage – Phase(s)</i> | | V– | Ph |
| Fréquence / <i>Frequency</i> | | Hz | |
| Puissance installée / <i>Installed power</i> | | kVA | |
| Intensité maxi / <i>Maxi amperage</i> | | A | |
| ENR-TRA-014 vE | |  | |

Manufacturer Plaque

Introduction

Your Geneglace ice machine has been designed and manufactured in accordance with current regulations; built with the greatest care, it has been subjected to a test for long-lasting quality. Nevertheless, if you discover a manufacturing fault and in order to protect your Geneglace machine, please do not attempt a repair but contact us as soon as possible. Any reproduction of all or part of this notice is subject to prior permission.

The information contained in this notice is subject to modification without prior notice.

In order to update the present notice, please advise us by return of any errors or misunderstandings that may have slipped in.

Geneglace SAS cannot be held responsible for damage or problems in operation occurring with Geneglace machines as a result of use outside the operating or safety limits or even the use of options or consumable items other than those approved by Geneglace SAS.

1. General

Important

Read the safety instructions carefully before working on the ice machine.

1.1 Introduction to this notice

Your GENEGLACE ice machine has been designed and manufactured in accordance with current regulations; built with the greatest care, it has been subjected to a test for long-lasting quality. Nevertheless, if you discover a manufacturing fault and in order to protect your GENEGLACE machine, please do not attempt a repair but contact us as soon as possible.

1.2 Warning

- Any reproduction of all or part of this notice is subject to prior permission.
- The information contained in this notice is subject to modification without prior notice.
- In order to update the present notice, please advise us by return of any errors or misunderstandings that may have slipped in.
- GENEGLACE cannot be held responsible for damage or problems in operation occurring with GENEGLACE machines as a result of use outside the operating or safety limits or even the use of options or consumable items other than those approved by GENEGLACE.

1.3 Where can you find the information you need?

After reading the safety instructions, the «Handling» section gives a list of the items that should come with your GENEGLACE, as well as instructions concerning handling with complete safety.

The layout will tell you about: the overall dimensions of your GENEGLACE, the procedure to follow for choosing the best location for it in relation to its environment and finally all information concerning accessibility for future service and maintenance.

«Connections»: In order to make all the hydraulic, electrical and cooling connections correctly, this section will give you some useful advice regarding the procedures for the connections.

To ensure that your GENEGLACE starts successfully the first time and not handling it incorrectly, refer to the Initial Start Up Sheets as well as this section.

The “Operation” section describes in detail all the operational features, factory settings and adjustments to be carried out.

The “Service, Maintenance and Fault Rectification” section will help you, by following its advice, to keep your GENEGLACE in optimum working condition for as long as possible.

Throughout this notice, you will find boxes such as :

Note

A note provides certain general information relevant to the subject treated.

Tip

The tip suggests procedures enabling you to surmount or get round any difficulties that may arise.

Important

This inset is intended to draw the attention of the reader to particular points that could be relevant to the safety of the operator or the machine.

2. Safety rules

This notice contains important rules to be observed concerning safety, installation, operation and maintenance of ice machines and their scrapping. And for this reason it must be read before any handling. In addition, a copy of the «Notice for Users», including the safety rules, must be continuously available to the user at the place of operation of the GENEGLACE.

An information board, indicating the type, identification number and certain operating and safety features of your GENEGLACE machine must always be visible and under no circumstances must it be removed.

The safety rules contained in this notice, as well as the national or local requirements for the prevention of accidents must also be observed.

2.1 Meaning of the danger pictograms

The safety rules appearing in GENEGLACE notices which, if not observed, could result in body injury, are preceded by the following symbols:



These symbols are also placed directly on the machine (or on certain spare parts), as well as arrows indicating the direction of rotation which must be observed. You must ensure that all these markings remain legible. Non-observance of these safety or operating instructions can result in equipment damage or incorrect operation of the machine, this instruction must be taken seriously.

2.2 Qualification and training of personnel

Personnel employed in operation, upkeep, maintenance and installation must be qualified for these tasks

Note that all local and regional regulations and safety standards, such as EN378, must be taken into account when designing, connecting and running the system.

Concerning accessibility to the machine by the public, the operator is responsible for protecting himself against any accident that may occur associated with its mechanical, electrical or chemical operation.

2.3 Danger in the event of non-observance of the safety rules

Non-observance of the safety rules can also result in physical danger, equipment danger or pollution of the environment.

Failure to observe the safety rules will result in the loss of rights to damages or compensation.

2.4 Operating range.

Important

Your GENEGLACE is designed to operate within the following limits :

| | |
|--------------------------------------|--|
| Type of fluid : | R404A - NH3 (for other fluids : consult us) |
| Maximum working pressure (MWP) | See page 7 |
| Ambient air temperature : (dry bulb) | + 5 to + 35°C + 41 to +95°F |
| Minimum evaporating temperature : | - 25°C (-13°F) |
| Temperature of water to be frozen : | + 5 to + 25°C +41 to +77°F |
| Mains water pressure : | 2 to 4 bar |
| Hardness of mains water : | TH 15 to 20° French degrees |
| Acidity of mains water : | PH 7/8 |
| Sodium chloride content : | about 100 g/m ³ . |
| Electrical protection : | IP 44 |

Any use of the GENEGLACE machine outside these limits could result in malfunctions, or even damage.
Altitude : if greater than 500 m, consult us.

Electrical supply : as indicated on the manufacturer's rating plate and in accordance with current standards.

3. Safety and Environmental Instructions

3.1 Safety rules

Starting and stopping a GENEGLACE.
Use the switch provided for this purpose on the electrical terminal box.
The use of a mains socket or an upstream isolating switch is prohibited.

Before operating, switch off the installation.



CAUTION

When stopping, the rotating part of the generator maintains a residual rotation that may cause an accident.

If it is difficult to reach the Start/Stop switch (machine mounted high up), request a remote control at a more convenient height.

If it is necessary to switch the machine off, use the isolating switch on the electrical terminal box (three phase). Lock the equipment with a padlock on the isolating switch to prevent inadvertent starting of the machine.

The principal area of danger is located inside the ice maker itself, enclosed by an upper cover and a base cover.

It is dangerous to place the hands or any object into this area while the rotating part is turning, for example during a normal cleaning operation of the water system.

It is recommended that the machine be stopped and switched off for cleaning or that the emergency switch on the upper part is used.

If the rotating part is driven by a reduction gear and a motor through a belt, a guard that can be removed by using tools is provided. Operation of the machine without this guard is prohibited.

The operation of manual valves is strictly reserved for maintenance personnel with the necessary skills (risk of spurting of fluids under pressure).

In the event of a general power failure, protect yourself against any risk when the power returns (unintended starting) : keep personnel away from dangerous areas.

Operation of the machine without the original safety equipment is prohibited: force limiter, electrical protection, pressostats, thermostats, transmission guards, etc. These devices must be maintained in working condition and the pictograms indicating the dangers must remain visible.

For all current maintenance operations mentioned in the user guide, it is advisable to stop the machine.

Other maintenance work, if required, must be carried out by an installer with the required skills.

Within the directives of the "MONTREAL PROTOCOL", any service work that might place the cooling system in communication with the atmosphere must be performed by skilled personnel.

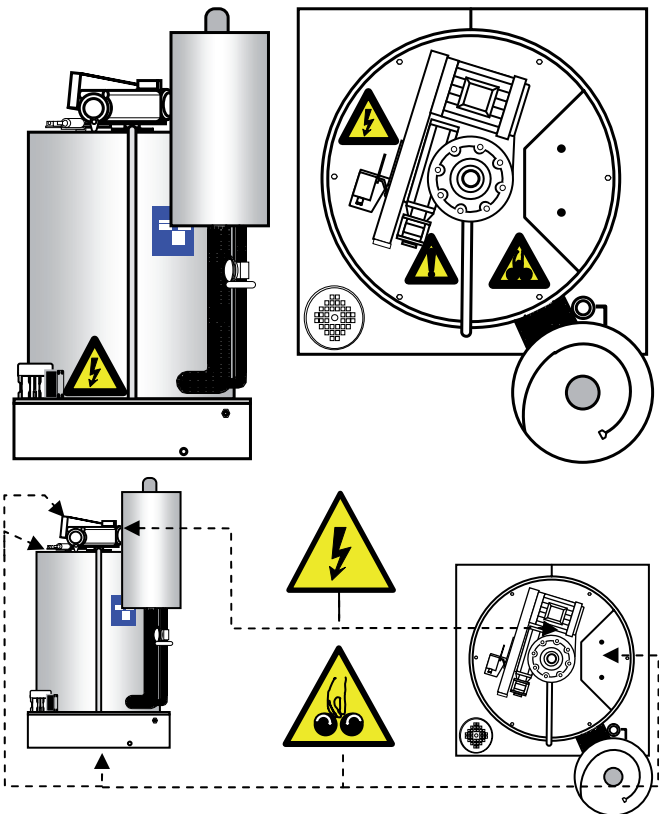

The drawing below indicates the principal dangerous areas of the GENEGLACE.

3.2 Protection of the Environment

Materials and fluids resulting from the disposal of machines must be treated via the approved channels in accordance with current regulations.



4. Safety concerning pressure vessels

| | | | |
|--------------|--|---|-------|
| IN02-1-VF9-A | GENEGLACE S.A.S Z.A.C de la forêt 9, rue des Orfèvres 44840 LES SORINIERES France | Operating instruction Specific to Geneglace pressure vessels according to PED 2014/68/UE | Page |
| | | | 1 / 1 |

Edition : 29/12/17

The Geneglace S.A.S. pressure vessel designated as « ice generator alone » is intended for installation in refrigerating plants, according to the EC Machines Directive 2006/42/EC and according to the Pressure Vessels Directive 2014/68/UE. It may be started-up only if it has been installed in such refrigerating plants, according to the following instructions and provided that the aforesaid plants comply as a whole with the national legislation.

This operating instruction complements the Geneglace service manual.

I.1 Residual danger

Certain residual dangers from the pressure equipment are unavoidable. All persons working on these units must therefore carefully read this operating instruction. All of the following have validity : specific

I.3 Safety provisions

I.3.1 **GENEGLACE ice generators operating limits:**

| Type | Volume (liters) | MWP (bar) | Category P.E.D | Group of Refrigerant | | T° Mini. (°C) | T° Máxi. (°C) | Maximum charge Kg | |
|------------------|-----------------|-----------|----------------|----------------------|------|---------------|---------------|-------------------|------------|
| | | | | R404A | R717 | | | R404A | R717 |
| F200 AB | 82 | 18.5 | III | | | -30 | +45 | 40 | 35 |
| F200 SBF | 35 | | | | | | | 18 | 15 |
| F250 AB | 112 | | | | | | | 55 | 50 |
| F250 SBF | 47 | | | | | | | 30 | 20 |
| F600 AB | 200 | | | | | | | 100 | 80 |
| F600 SBF | 90 | | | | | | | 60 | 40 |
| F800 AB | 325 | | IV | 2 | 1 | -30 | +45 | 180 | 130 |
| F800 SBF | 190 | | | | | | | 125 | 85 |
| F800-2 AB | 715 | | | | | | | 350 | 300 |
| F900 AB | 485 | | | | | | | 260 | 200 |
| F900 SBF | 260 | | | | | | | 145 | 100 |
| F2000 AB | 745 | | | | | | | 370 | 260 |
| F2000 SBF | 405 | | | | | | | | |
| | | | | | | | | | |

I.3.2 **Maximum working Pressure**

The entire plant should be designed and operated so that the **maximum working pressure (MWP)** in the ice generator cannot be exceeded. Pressure relief valves must be fitted and must be correctly rated according to current local regulations. (These will be supplied and fitted by the installer)

I.3.3 **Safety switching device**

Temperature and pressure limiting safety switching devices must be provided in compliance with local regulations.

I.3.4 **Pump-down**

To limit the build up of coolant when high pressure vessel is stopped, a timed pump down device is necessary when Geneglace generators are stopped.

rules for the prevention of accidents ; generally accepted safety standards ; EU guidelines ; national standards and regulations.

I.2 Location

When installed in extreme conditions, (e.g. aggressive atmospheres, low ambient temperatures etc.), suitable measures must be taken. Consultation with GENEGLACE SAS is recommended.

Caution !

- GENEGLACE ice generators are intended to be installed in low pressure sides of refrigerating plants.
- GENEGLACE ice generators mustn't be used as refrigerant storage tanks.

I.4 Registration, mounting, commissioning, maintenance of pressure vessels PED 2014/68/UE

GENEGLACE ice generators are pressure vessels according to the Pressure Vessels Directive 2014/68/UE.

For this reason, the entire plant must be registered with the supervisory authority and duly approved in compliance with local regulations.

- A declaration of incorporation and conformity CE is provided with the pressure vessels.
- Mounting, commissioning and maintenance must comply with this operating instruction and with the GENEGLACE service manual.
- The pressure vessel must be periodically inspected by authorized personnel. The inspection intervals depend on refrigerant and mode of operation. They must be determined by the end user.

In countries outside of EU the applicable regulations must be complied with.

5. Handling

The ice machine must be maintained by qualified staff. Every precaution must be taken to ensure the safety of staff and the machine during maintenance.
Slings must be of sufficient size and breaking strain.

5.1 Générateurs F200; F250; F600.

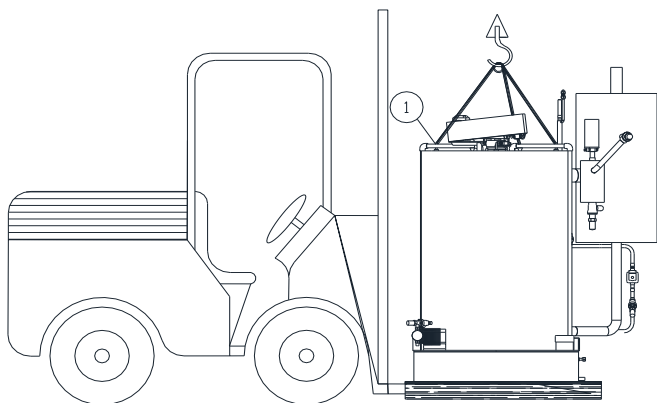

Rep 1 = 3 rings transfert

| Générateur | | Poids net | |
|------------|-----|------------|--------|
| Generator | | Net weight | |
| Generador | | Peso neto | |
| Generatore | | Peso netto | |
| | | Kg | (lbs) |
| F200 | ABF | 510 | (1124) |
| | SBF | 460 | (1014) |
| F250 | ABF | 700 | (1543) |
| | SBF | 620 | (1367) |
| F600 | ABF | 970 | (2138) |
| | SBF | 850 | (1874) |

5.2 Générateurs F800; F900; F2000.

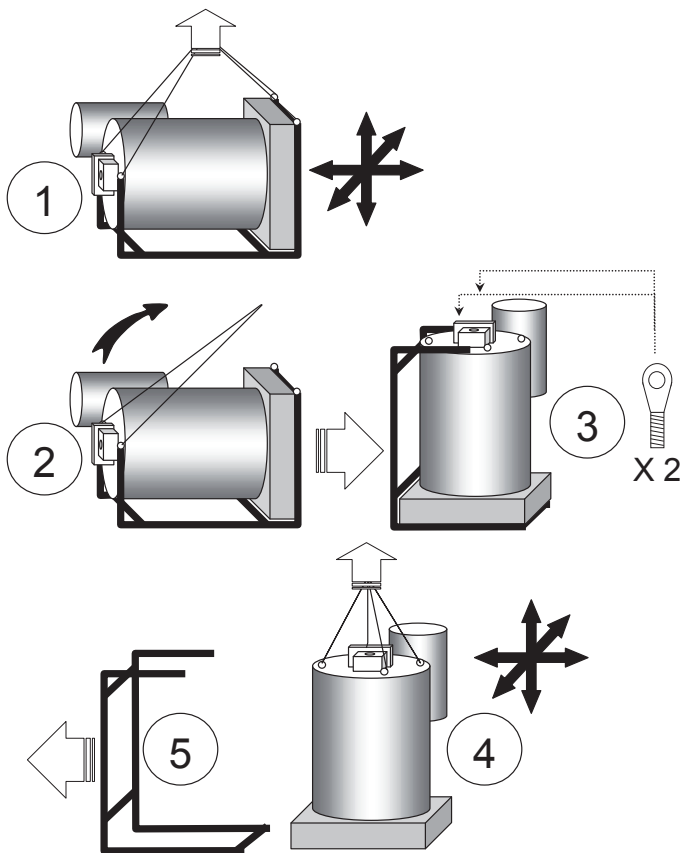

Rep 1 = Horizontal handling.

Rep 2 = Set in vertical position.

Rep 3 = Lifting rings transfert.

Rep 4 = Lifting.

Rep 5 = Removal of shippin cradle.

| Générateur | | Poids net | |
|------------|-----|------------|---------|
| Generator | | Net weight | |
| Generador | | Peso neto | |
| Generatore | | Peso netto | |
| | | Kg | (lbs) |
| F800 | ABF | 2 500 | (5512) |
| | SBF | 2 300 | (5071) |
| F900 | ABF | 3 100 | (6834) |
| | SBF | 2 800 | (6173) |
| F2000 | ABF | 5 200 | (11464) |
| | SBF | 4 800 | (10582) |

6. Dimensions

Generator ABF

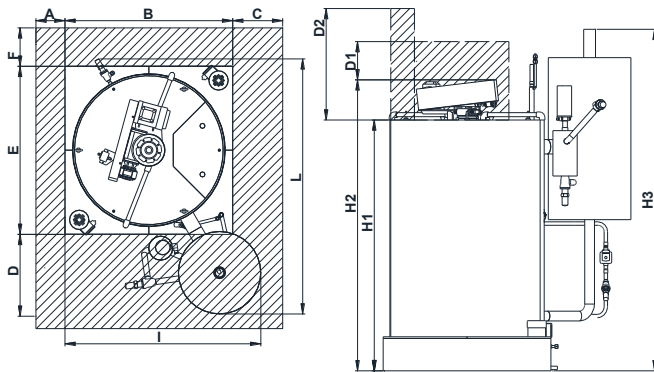

Generator SBF

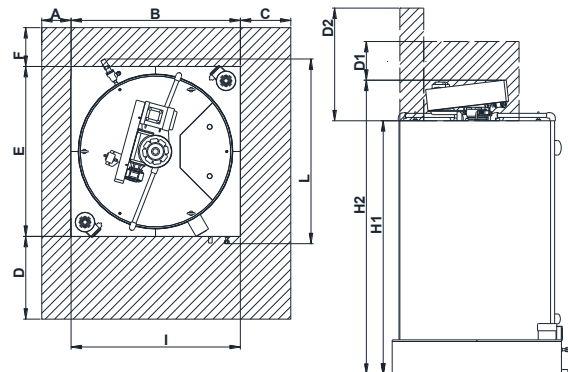

| Générateur Generator Generador Generadore | | F200 | | F250 | | F600 | | F800 | | F900 | | F2000 | |
|--|------|--------|--------|--------|--------|--------|--------|--------|--------|--------|--------|--------|--------|
| | | ABF | SBF | ABF | SBF | ABF | SBF | ABF | SBF | ABF | SBF | ABF | SBF |
| A | mm | 500 | 500 | 500 | 500 | 500 | 500 | 500 | 500 | 500 | 500 | 500 | 500 |
| | inch | 19,685 | 19,685 | 19,685 | 19,685 | 19,685 | 19,685 | 19,685 | 19,685 | 19,685 | 19,685 | 19,685 | 19,685 |
| B | mm | 850 | 850 | 850 | 850 | 1040 | 1040 | 1290 | 1290 | 1580 | 1580 | 2080 | 2080 |
| | inch | 33,46 | 33,46 | 33,46 | 33,46 | 40,94 | 40,94 | 50,79 | 50,79 | 62,20 | 62,20 | 81,89 | 81,89 |
| C | mm | 300 | 300 | 300 | 300 | 500 | 500 | 500 | 500 | 600 | 600 | 600 | 600 |
| | inch | 11,81 | 11,81 | 11,81 | 11,81 | 19,68 | 19,68 | 19,68 | 19,68 | 23,62 | 23,62 | 23,62 | 23,62 |
| D | mm | 1300 | 1000 | 1400 | 1000 | 1700 | 1000 | 1800 | 1000 | 2200 | 1000 | 2200 | 2200 |
| | inch | 51,18 | 39,37 | 55,12 | 39,37 | 66,93 | 39,37 | 70,87 | 39,37 | 86,61 | 39,37 | 86,61 | 86,61 |
| D1 | mm | 300 | 300 | 300 | 300 | 300 | 300 | 400 | 400 | 400 | 400 | 400 | 400 |
| | inch | 11,81 | 11,81 | 11,81 | 11,81 | 11,81 | 11,81 | 15,75 | 15,75 | 15,75 | 15,75 | 15,75 | 15,75 |
| D2 | mm | 1060 | 1060 | 1360 | 1360 | 1360 | 1360 | 1980 | 1980 | 1980 | 1980 | 1980 | 1980 |
| | inch | 41,73 | 41,73 | 53,54 | 53,54 | 53,54 | 53,54 | 77,95 | 77,95 | 77,95 | 77,95 | 77,95 | 77,95 |
| E | mm | 850 | 850 | 850 | 850 | 1040 | 1040 | 1290 | 1290 | 1580 | 1580 | 2080 | 2080 |
| | inch | 33,46 | 33,46 | 33,46 | 33,46 | 40,94 | 40,94 | 50,79 | 50,79 | 62,20 | 62,20 | 81,89 | 81,89 |
| F | mm | 200 | 200 | 200 | 200 | 500 | 500 | 500 | 500 | 500 | 500 | 500 | 500 |
| | inch | 7,87 | 7,87 | 7,87 | 7,87 | 19,68 | 19,68 | 19,68 | 19,68 | 19,68 | 19,68 | 19,68 | 19,68 |
| H1 | mm | 1250 | 1250 | 1550 | 1550 | 1550 | 1550 | 2350 | 2350 | 2350 | 2350 | 2350 | 2350 |
| | inch | 49,21 | 49,21 | 61,02 | 61,02 | 61,02 | 61,02 | 92,52 | 92,52 | 92,52 | 92,52 | 92,52 | 92,52 |
| H2 | mm | 1480 | 1480 | 1800 | 1800 | 1800 | 1800 | 2750 | 2750 | 2750 | 2750 | 2750 | 2750 |
| | inch | 58,27 | 58,27 | 70,87 | 70,87 | 70,87 | 70,87 | 108,27 | 108,27 | 108,27 | 108,27 | 108,27 | 108,27 |
| H3 | mm | 1750 | - | 2050 | - | 2050 | - | 3100 | - | 3100 | - | 3100 | - |
| | inch | 68,90 | - | 80,71 | - | 80,71 | - | 122,05 | - | 122,05 | - | 122,05 | - |
| I | mm | 940 | 850 | 970 | 850 | 1200 | 1050 | 1550 | 1300 | 1950 | 1680 | 2435 | 2080 |
| | inch | 37,01 | 33,46 | 38,19 | 33,46 | 47,24 | 41,34 | 61,02 | 51,18 | 76,77 | 66,14 | 95,87 | 81,89 |
| L | mm | 1230 | 950 | 1300 | 950 | 1500 | 1050 | 1550 | 1300 | 1950 | 1700 | 2435 | 2080 |
| | inch | 48,43 | 37,40 | 51,18 | 37,40 | 59,05 | 41,34 | 61,02 | 51,18 | 76,77 | 66,93 | 95,87 | 81,89 |

D1 = Minimum clearance for reducer removal.

D2 = Minimum clearance for reamer removal.

7. Positioning the machine

- Place the generator on a level, flat surface.
- The generator must be located in a position protected from bad weather, water spray or any other liquid and in a non-aggressive environment.
- Position the generator so as to maintain adequate access for upkeep and maintenance (see Installation Handling - free access)
- The generator must be mounted sufficiently high, in order to permit suitable storage for its daily production of ice (e.g. cold chamber, static or orbital silo, etc.).
- Avoid locating the ice output in the air flow from an evaporator.
- Do not reduce the cross section of the ice output.

Note

In order to facilitate all upkeep and maintenance work on the generator, (such as regular greasing of the bearings of the shaft and the reamer), provide accessibility below and above the machine.

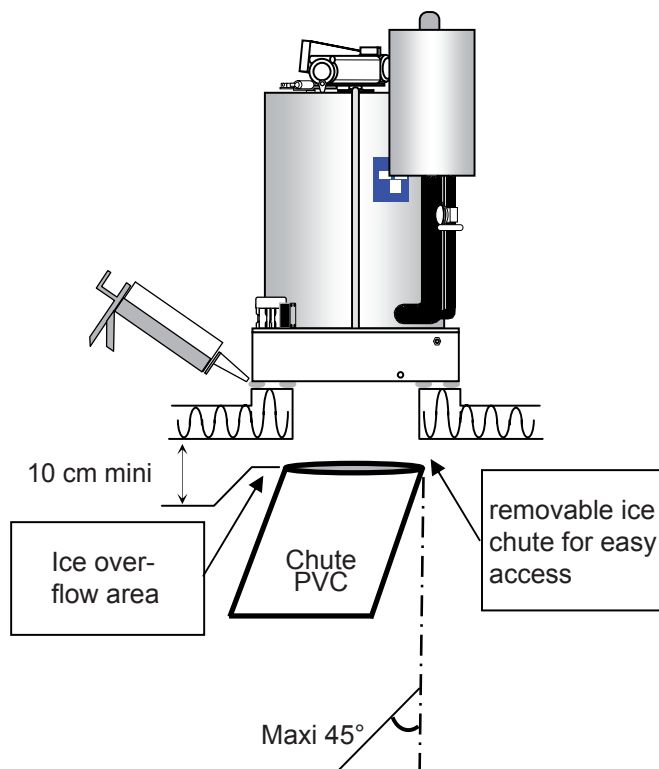

Fig 512. Optional chute, easily removable for maintenance of generator.

Important

Risk of freezing: protect the base of the pump and valve float by means of a heater housed in the base.

This device will only be effective for an air temperature of - 10°C maximum for a period of 12 to 24 h. Beyond that, it is preferable to drain the machine if it is stopped. Also protect the water supply pipework.

Note

When fitting a heater resistance, provide a circuit breaker for protection and a thermostat to monitor the ambient air temperature.

7.1 Mountings

The opening in the generator mounting must be at least equal to the diameter «G» of the ice chute.

Important

Do not forget to add a silicone seal all round the base of the generator to prevent water entering the ice storage area.

Seal with mastic before fitting and mount the generator with threaded rods inserted through the tubular spacers and also sealing the latter inside the water tray base and the cross members of the floor.

If necessary, fit a heat-proof washer with the dimensions shown on the installation drawing to prevent condensates on the lower surface of the base.

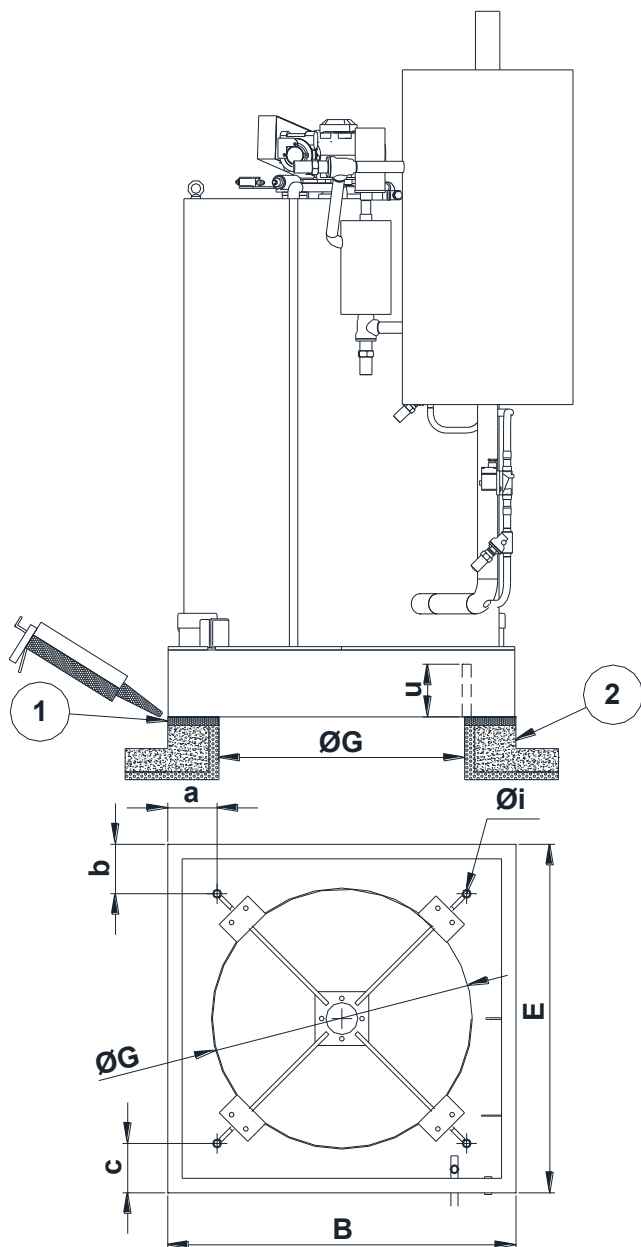

Rep 1 = Tightness seal around the boring.

Rep 2 = Raising of the floor to avoid accidental water leaks in the storage.

| Générateur Generator Generador Generadore | | F200 | F250 | F600 | F800 | F900 | F2000 |
|--|------|-------|-------|-------|-------|-------|-------|
| ØG | mm | 680 | 680 | 780 | 960 | 1200 | 1780 |
| | inch | 26,77 | 26,77 | 30,71 | 37,80 | 47,24 | 70,08 |
| Øi | mm | 20 | 20 | 20 | 35 | 35 | 35 |
| | inch | 0,79 | 0,79 | 0,79 | 1,38 | 1,38 | 1,38 |
| u | mm | 150 | 150 | 180 | 310 | 310 | 310 |
| | inch | 5,91 | 5,91 | 7,09 | 12,20 | 12,20 | 12,20 |
| a | mm | 87 | 87 | 147 | 220 | 260 | 297,5 |
| | inch | 3,43 | 3,43 | 5,79 | 8,66 | 10,24 | 11,71 |
| b | mm | 87 | 87 | 147 | 220 | 260 | 297,5 |
| | inch | 3,43 | 3,43 | 5,79 | 8,66 | 10,24 | 11,71 |
| c | mm | 87 | 87 | 147 | 220 | 260 | 297,5 |
| | inch | 3,43 | 3,43 | 5,79 | 8,66 | 10,24 | 11,71 |

7.2 Setting up specific

7.2.1 Assembly of the bottle flood

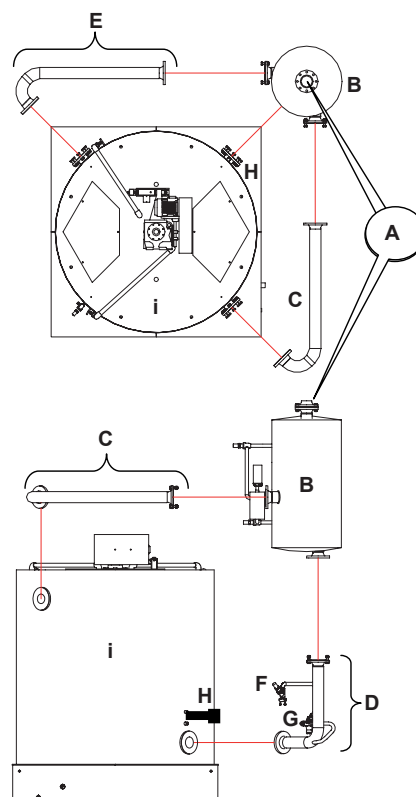

The assembly of the bottle **B** must be carried out after having positioned the generator.

To position piping **D**, to place the joint of flange, to screw the screws (20x70) on the flange cylinder **i** (without blocking them).

To connect the supports **F** you **G** with their joints on piping **H** fixed on cylinder **i** (without blocking them).

Using a means of adapted lifting, to raise the bottle **B** by point **A**, so that the flanges (piping **D** - bottle) are on the same level to place the joint of flange, to screw the screws (20x70) on the flange bottle **B** (without blocking them).

To take piping **C**, to screw the screws (20x70) on the flange cylinder **i** while placing the joint of flange, then to screw the screws (20x70) on the flange bottle **B** while placing the joint of flange (without blocking them).

To take piping **E**, to screw the screws (20x70) on the flange cylinder **i** while placing the joint of flange, then to screw the screws (20x70) on the flange bottle **B** while placing the joint of flange (without blocking them).

Once checked the good assembly of all the flanges, to block all the screws (410 Nm Maxi), and to remove the system of lifting of the bottle.

7.2.2 Repositioning the torque limiter on F800

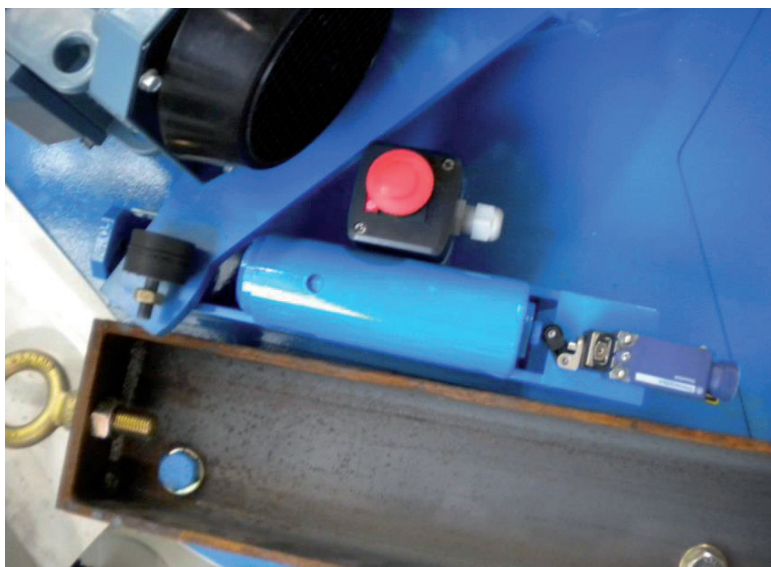

Positioning the reducer and Torque Limiter on the transport cradle (chassis)

- Place the generator vertically and remove the transport cradle.
- Locate the bag containing the eye bolts and torque limiter screws
- Unscrew the screws securing the torque limiter to the upper part
- Rotate the reducer motor/torque limiter assembly (anti-clockwise) 1/4 of a turn
- Mount the torque limiter (see position below) with the 3 screws, inserting the torque arm into it

Positioning of the Reducer Motor and Torque Limiter for commissioning

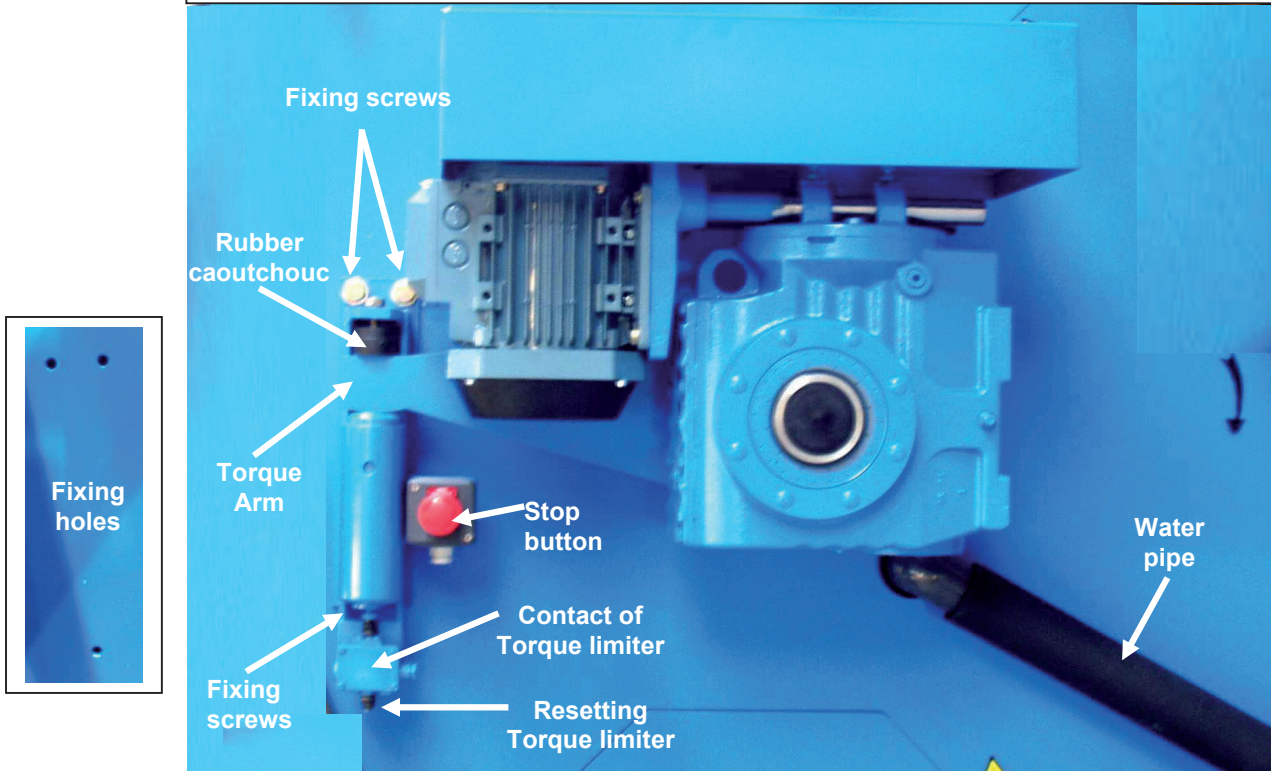

8. Connections

8.1 Hydraulic connections

| Hydraulic Connections | | | | | | | | | |
|-----------------------|--------------|-------------------|-------------|-------------|------|-------------|------|-------------|------|
| Item. | Description | Type | Material | Connections | | | | | |
| | | | | Dimensions | Qty. | Dimensions | Qty. | Dimensions | Qty. |
| A | Water supply | Threaded | | F200 | | F250 | | F600 | |
| | | | | 1/2" gaz | 1 | 1/2" gaz | 1 | 1/2" gaz | 1 |
| | | | | F800 | | F900 | | F2000 | |
| | | | | 1/2" gaz | 2 | 1/2" gaz | 2 | 1/2" gaz | 4 |
| B | Overflow | Plain ends tube | Stainless * | F200 | | F250 | | F600 | |
| | | | | 22x1 mm | 1 | 22x1 mm | 1 | 26,9x2,6 mm | 1 |
| | | | | F800 | | F900 | | F2000 | |
| | | | | 48,3x3,7 mm | 1 | 48,3x3,7 mm | 1 | 48,3x3,7 mm | 1 |
| C | Water drain | Internal Threaded | Stainless * | F200 | | F250 | | F600 | |
| | | | | 1/2" gaz | 1 | 1/2" gaz | 1 | 1/2" gaz | 1 |
| | | | | F800 | | F900 | | F2000 | |
| | | | | 3/4" gaz | 1 | 3/4" gaz | 1 | 3/4" gaz | 1 |

* F800; F900 et F2000 = Steel

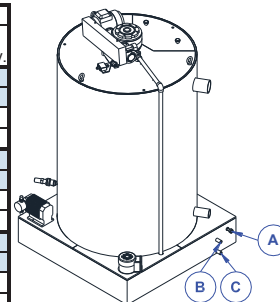

Recommendation

Risk of frost: fit the water supply and overflow pipes with a device (insulation and/or heater) to protect them against freezing.

8.2.1 Connection to the water supply

The water supply should preferably be connected by a flexible hose to the 1/2 Flare. Rigid pipe can also be used.

Note

It is a good idea to fit a shut-off valve on the water supply to facilitate maintenance

When tightening the flange connector, hold the float valve so that its water outlet is perpendicular to the bottom of the base in order to maintain freedom of action of the float arm.

Important

In order to prevent malfunctions of your GENEGLACE and from a food hygiene point of view, it is a good idea to fit a water filter or purifier as required.

In fact, filtering the water supply may considerably slow down the deposition of impurities in your GENEGLACE, but not scale formation. For this reason, when the hardness of the water is too high, it will be necessary to use a water softener.

Important

In order to prevent malfunctions of your GENEGLACE it is a good idea to fit a device for protection against falls in pressure or water flow rate.

the water supply pressure must be between 2 bar minimum and 4 bar maximum. The water flow rate must always be constant and greater than that due to the water consumption of your GENEGLACE. If this is not the case, the installation of a pump and reservoir and/or an expansion valve is essential.

The water consumption of your GENEGLACE is equal to its ice production.

8.1.2 Overflow connection

In the event of malfunction of the float valve, the excess water escapes through the overflow. The overflow therefore prevents any overflow of water through the ice descent hole and thus into the ice bin.

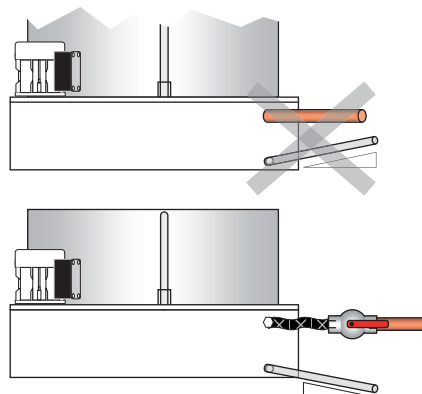

The overflow water must flow into the drains as required by the regulations.

The drain pipe must not have a rising portion that could prevent the natural flow of water, and its slope must be sufficient.

8.2 Electrical connection

The type of electrical power supply is stated on the rating plate attached to the generator.

Ensure that the electrical supply for your GENEGLACE complies with the regulations in force and in the following respects :

- voltage (Volts)
- three phase or single phase (3 or 1)
- frequency (Hz)
- installed power (KVA)
- nominal current (A)

An electrical control box is obligatory to control the operation of the generator. The electrical sequences and current regulations must be followed (refer to the functional diagram section).

Important

The cross section of the electrical supply cable must be adequate for the installed power of the machine (see rating plate) and comply with current standards. An electrical protection device complying with current standards must be fitted to protect the various parts of the machine. Using the electrical diagram of the machine, check the polarity of the electrical connection of single phase generators.

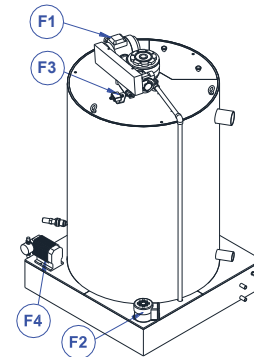
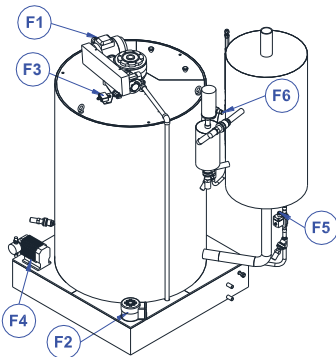

| Electrical Connections | | | | | | | | |
|------------------------|---------------------------------|---|---|------------|-----------|-----------|-----------|---|
| Item. | Description | F200 | F250 | F600 | F800 | F900 | F2000 | |
| F1 | Reamer motor | Qty. | 1 | 1 | 1 | 1 | 1 | |
| | | Power Supply | 400V-3-50Hz | | | | | |
| | Nominal Power | 1 x 250 W | 1 x 250 W | 1 x 250 W | 1 x 550 W | 1 x 550 W | 1 x 550 W | |
| | Nominal Amperage | 1 x 0,95 A | 1 x 0,95 A | 1 x 0,95 A | 1 x 2,5 A | 1 x 2,5 A | 1 x 2,5 A | |
| F2 | Pump | Qty. | 1 | 1 | 2 | 1 | 1 | 2 |
| | | Power Supply | 230V-1-50Hz | | | | | |
| | Nominal Power | 1 x 70 W | 1 x 70 W | 2 x 70 W | 1 x 300 W | 1 x 300 W | 2 x 300 W | |
| | Nominal Amperage | 1 x 0,35 A | 1 x 0,35 A | 2 x 0,35 A | 1 x 1,4 A | 1 x 1,4 A | 2 x 1,4 A | |
| F3 | Torque limiter switch | Qty. | 1 | | | | | |
| | Switch | | 1 NC / 1 NO | | | | | |
| F3 | Emergency Troque limiter switch | Qty. | 1 | | | | | |
| | | Switch | 1 NC / 1 NO | | | | | |
| F4 | Salt dosing pump* (*Optional) | Qty. | 1 | | | | | |
| | | Power Supply | 230V-1-50Hz | | | | | |
| | Nominal Power | 1 x 50 W | | | | | | |
| | Nominal Amperage | 1 x 0,4 A | | | | | | |
| F5 | Solenoid valve | Qty. | 1 | | | | | |
| | | Power Supply | 230V-1-50Hz | | | | | |
| | Nominal Power | 1 x 10 W | | | | | | |
| | Nominal Amperage | 1 x 0,1 A | | | | | | |
| F6 | Liquid level control | Qty. | 1 | | | | | |
| | | Power Supply | (ac) U = 20 - 264 V (50/60Hz) / (dc) U = 20 - 60V | | | | | |
| | | Nominal Amperage | I < 6mA | | | | | |
| | | Switch | 1 NO | | | | | |
| | | Max voltage switch | (ac) U = 250V / (dc) U = 60V | | | | | |
| | Max power switch | (ac) 1250VA, cosφ= 1 / 1000VA, cosφ=0,7 | | | | | | |
| | Max amperage switch | (ac) 5 A / (dc) 5 A, U<30V / 1,5 A, U<60V | | | | | | |

8.2.1 Reamer motor

In the case of a three phase supply, connect as appropriate for the characteristics of the electrical supply. The motors are supplied connected in star.

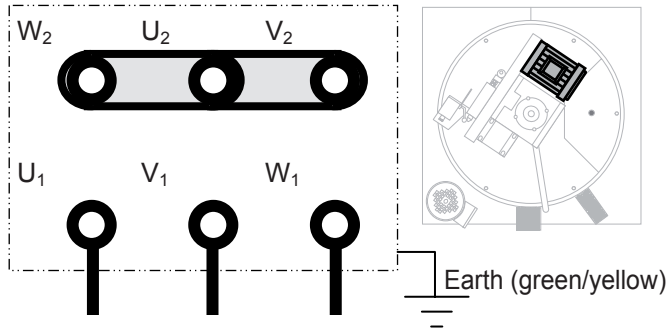
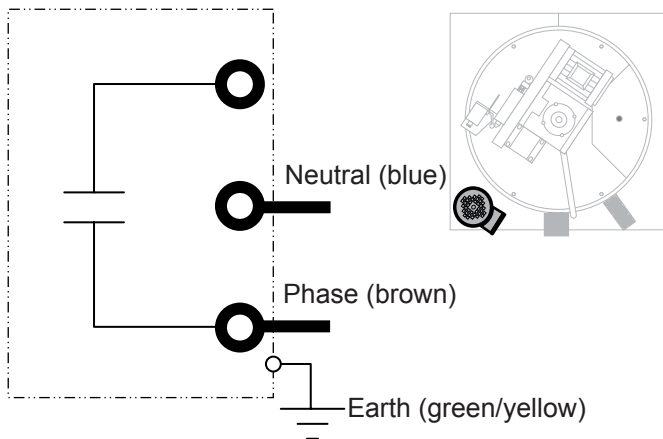

Fig. Electrical connection diagram for reamer motor.

If the moving parts assembly does not turn in the direction indicated by the arrow on the top, reverse the connection of two phases.

8.2.2 Water pump

The water pump operates from 220 Volts, single phase and is fitted in advance with a 3 m cable. However if the cable has to be changed, the connections must be as follows:



8.2.3 Salt dosing pump

The salt dosing pump operates from 220 Volts, single phase and is fitted in advance with a 1 m cable.

8.2.4 Torque limiter switch

The torque limiter is been with two parts : switch with mecanical system and ernaly emergency stop switch

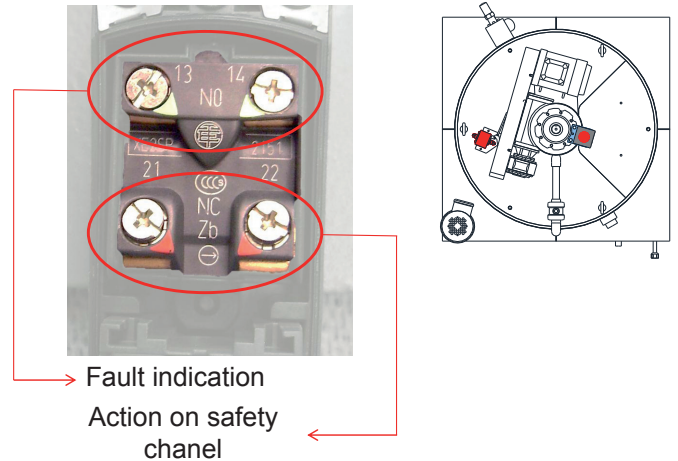

Fig. Electrical connection for torque limiter switch.

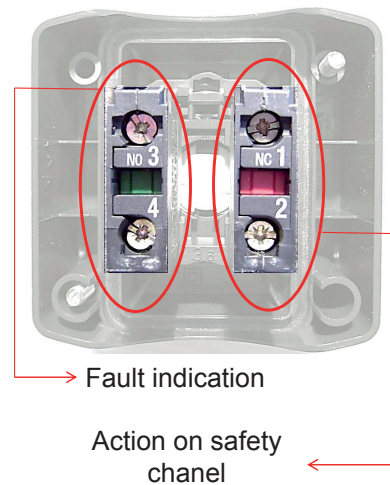
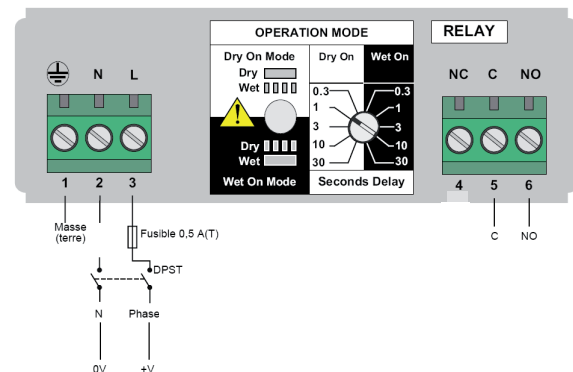

Fig. Electrical connection for emergency stop switch of torque limiter

8.2.5 Liquid level control

Vibrating fork liquid level detector version :



Float ball liquid level detector version :

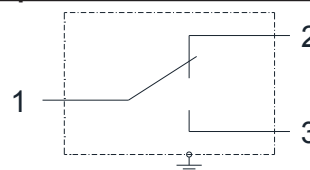

Note

In all the above cases, do not forget to connect the earth terminals.

8.3 Connections to the refrigerant circuit

Refer to the section «Safety Concerning Pressure vessels»

Générateur ABF

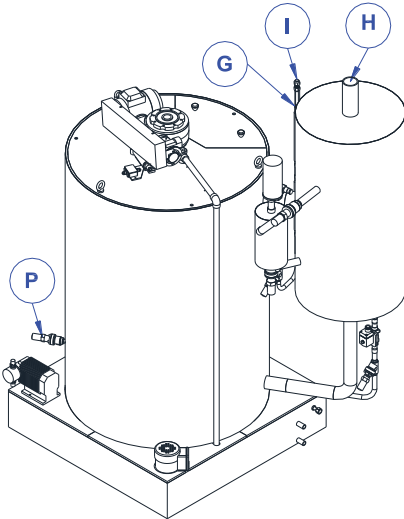

Générateur ABF
NH3

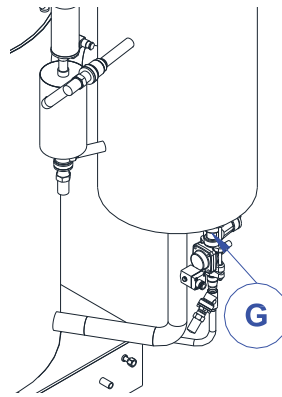

Générateur SBF

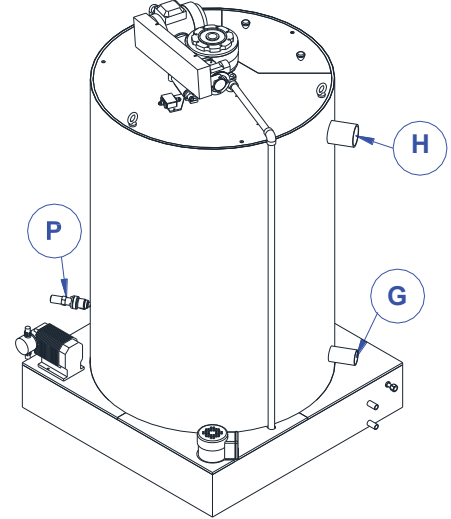

| Refrigerating Connections | | | | | | | | | | | | | | | |
|---------------------------|--------------|-------------------------------|-------------------------------|-------------|------------|-------------|------|------------|------------|-------------|------|------------|------------|-------------|---|
| Item. | Description | Type | Material | Connections | | | | | | | | | | | |
| | | | | Dimensions | | | Qty. | Dimensions | | | Qty. | Dimensions | | | |
| | | | | ABF | NH3 | SBF | | R404A | NH3 | SBF | | R404A | NH3 | SBF | |
| G | Liquid inlet | R404A = O.D.F NH3 = Flange | R404A = Copper NH3 = Steel | F200 | | | 1 | F250 | | | 1 | F600 | | | 1 |
| | | | | 7/8" | 33,4 mm | 48,3x3,7 mm | | 7/8" | 33,4 mm | 48,3x3,7 mm | | 7/8" | 33,4 mm | 60,1x3,9 mm | |
| | | | | F800 | | | | F900 | | | | F2000 | | | |
| H | Suction | Plain ends tube | Steel | F200 | | | 1 | F250 | | | 1 | F600 | | | 1 |
| | | | | 48,3x3,7mm | 48,3x3,7mm | 60,3x3,9 mm | | 60,3x3,9mm | 60,3x3,9mm | 73x5,16 mm | | 73x5,16 mm | 73x5,16 mm | 88,9x5,5 mm | |
| | | F800 | | | F900 | | | F2000 | | | | | | | |
| | | Flange | | DN 65 | DN 80 | 168,3x11 mm | | DN 80 | DN 80 | 168,3x11 mm | | DN 100 | DN 100 | DN 100 | |
| I | Oil return | O.D.F | Copper | F200 | | | 1 | F250 | | | 1 | F600 | | | 1 |
| | | | | 3/8" | | | | 3/8" | | | | 3/8" | | | |
| | | | | F800 | | | | F900 | | | | F2000 | | | |
| | | | | 1/2" | | | | 1/2" | | | | 1/2" | | | |
| P | Oil drain | O.D.M.-G | Stainless steel | F200 | | | 1 | F250 | | | 1 | F600 | | | 1 |
| | | | | 3/8" | 3/8" | 3/8" | | 3/8" | 3/8" | 3/8" | | 3/8" | 3/8" | 3/8" | |
| | | | | F800 | | | | F900 | | | | F2000 | | | |
| | | | | 3/8" | 3/8" | 3/8" | | 3/8" | 3/8" | 3/8" | | 3/8" | 3/8" | 3/8" | |

8.3.1 General topics concerning the liquid and suction pipes

Important

Every precaution must be taken to ensure that the refrigerant piping is clean and free from moisture and enhances oil return to the compressor.

The connections between the liquid line and the suction line shall need to follow the same alignment as the connection joints of the generator.

If this is not done, it is possible that cracks or even breaks in the pipe may appear.

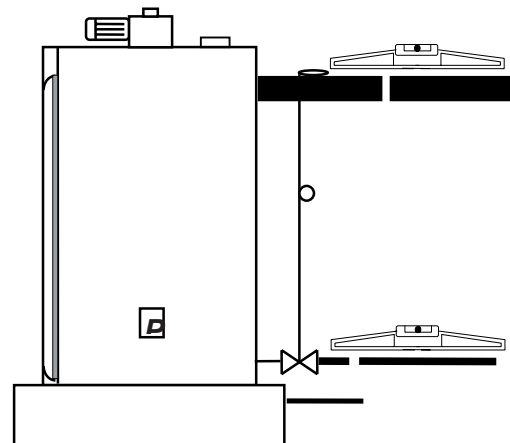

The pipes must be fixed at regular intervals and the fixings must rest on a mounting which will prevent movement of the pipes and absorb the maximum amount of vibration.

As a matter of safety, it is advisable not to use pipes as steps, or as a support for other equipment.

Regarding the intake pipe, as far as possible the pressure drop between the generator and the compressor must be as small as possible (take this into account for calculations).

For the position of the bulb of the thermostatic expansion valve, refer to the section : Cooling system diagrams.

8.3.1.1 Compressor

The coolant compressor must be fitted with a crankcase heater

8.3.1.2 Oil separator

The installation of an oil separator is required to prevent compressor oil from reaching the circuit components. This enables :

To maintain a low concentration of oil and thereby ensure an optimum coefficient of thermal conduction.

To eliminate the risks of abnormal mechanical wear of the compressor further to a lack of oil in the crankcase

To reduce the pressure drop in the installation piping.

The oil separator must be selected in accordance with best current practice, the concentration of oil obtained after the separator must be a maximum of 80 ppm.

8.3.2 Generator and remote condensing unit located at same levels

The normal diameters of pipes can be retained for a maximum developed length of 6 m (20 ft)

For the diameters of the pipes, refer to the table of Dimensions and Connection.

8.3.3 Generator and remote condensing unit located at different levels

In the case where the compressor and the generator are mounted at different levels, certain precautions concerning the piping must be taken into account.

8.3.3.1 Suction line

The suction line must be arranged with a slope descending towards the compressor and any part of the piping that could constitute a fluid trap must be avoided.

Suction gas velocity must be high enough to provide for an adequate oil return. This velocity must be within 8 to 12 m/s (23 to 39 ft/s) in vertical risers.

In horizontal pipes, this velocity can decrease to 4 m/s (13 ft/s)

The use of U-traps and double-suction risers may be required on vertical sections, wherever elevation exceeds 2 m (6,5 ft). Where elevation exceeds 4 m (13 ft), it is advisable to install a U-trap every 2 to 3 m (6.5 to 10 ft).

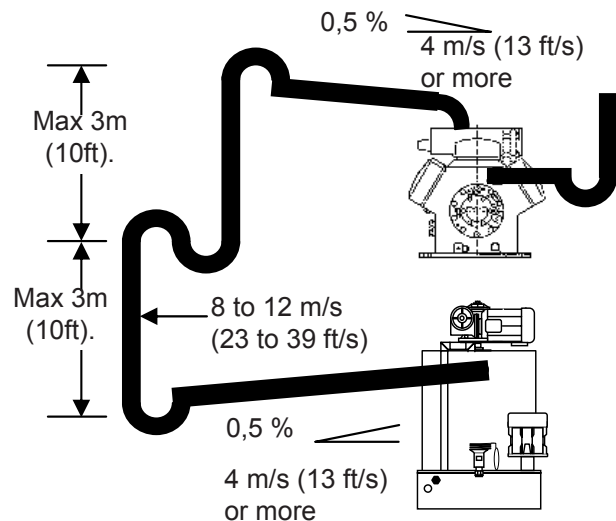

The thermal insulation must prevent the diffusion of water vapour it (this is to avoid rotting of the insulating material).

Suction line piping must be insulated (according to local climate) in order to minimize the superheat effects.

Note that all local and regional regulations and safety standards, such as EN378, must be taken into account when designing, connecting and running the system.

8.3.3.2 Liquid Line

Any gas trap must be avoided, that is any section of piping in an inverted «U» so as to prevent any interruption of the liquid flow.

A solenoid valve on the liquid line must shut off the refrigerant feed to the generator in order to avoid any risk of slugging to the compressor.

Where the difference in elevation between generator and compressor is greater than 5 m (16.5 ft) approx., it is recommended that the diameter of the liquid line be increased.

In this case, the selection of the expansion valve may have to be reconsidered, no longer taking into account the condensation pressure but the pressure existing upstream of the expansion valve.

8.3.4 Generator connected to a central refrigerating plant

The installer should make provision for the following components :

- Evaporating pressure regulator with pressure gauge connector.
- Pressure relief valve in accordance with current local regulations.

Option : it is possible to install a safety level control on the flood bottle (high alarm option).

Electrical equipment to be supplied by the installer : refer to the section : Operating Diagram

Warning

Running the generator outside of the normal range specified by GENEGLACE is not recommended.

8.3.5 Refrigeration Diagram

8.3.5.1 Generators with flood bottles (AB version) R404A :

| | |
|----|---|
| 1 | Generator |
| 2 | HP Liquid |
| 3 | Oil return heat exchanger (F200 – F250 = 1) |
| 4 | Suction |
| 5 | Vertical surge drum (flood bottle) |
| 6 | Liquid Level Control |
| 7 | liquid solenoid valve |
| 8 | Manual throttle |
| 9 | Manual oil return valve |
| 10 | Oil drain |
| 11 | LP pressure relief valve – (not included) |

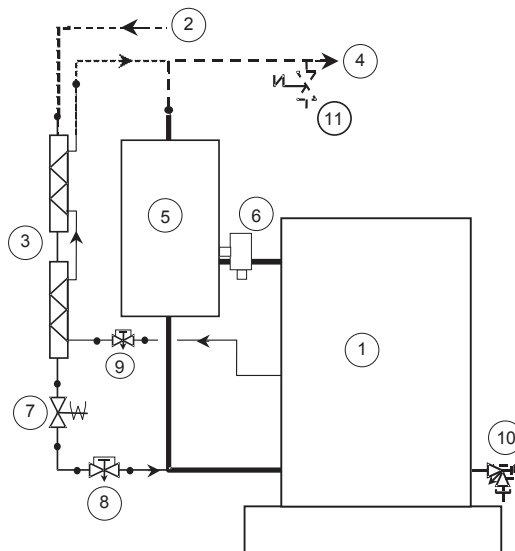

Refrigeration diagram F200 - F250 - F600 ABF

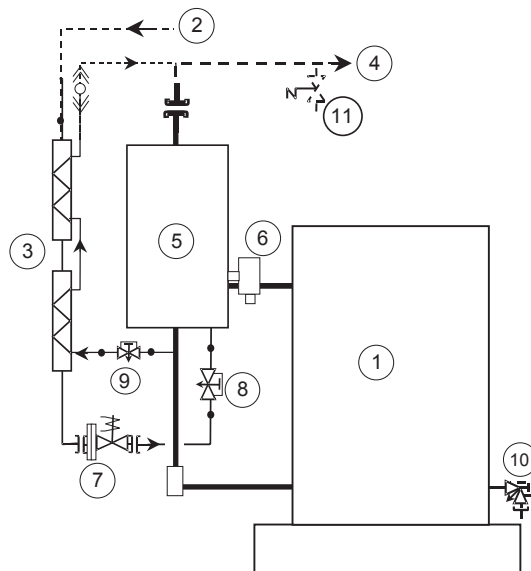

Refrigeration diagram F800 - F900 ABF

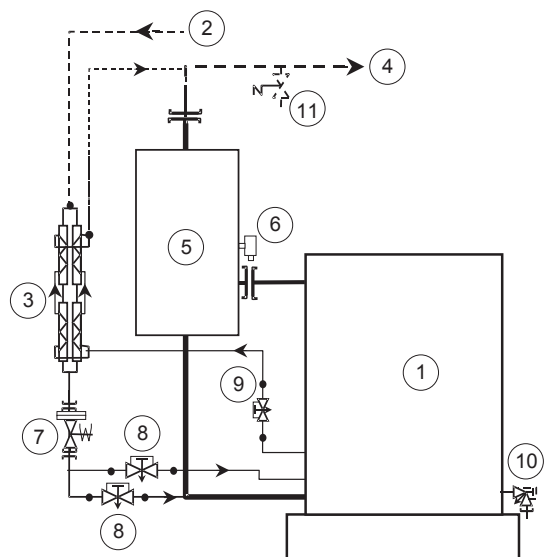

Refrigeration diagram F2000 ABF

NH3 :

| | |
|---|---|
| 1 | Generator |
| 2 | HP Liquid |
| 3 | Filter + liquid solenoid valve |
| 4 | Suction |
| 5 | Vertical surge drum (flood bottle) |
| 6 | Liquid Level Control |
| 7 | Manual throttle |
| 8 | Oil drain |
| 9 | LP pressure relief valve – (not included) |

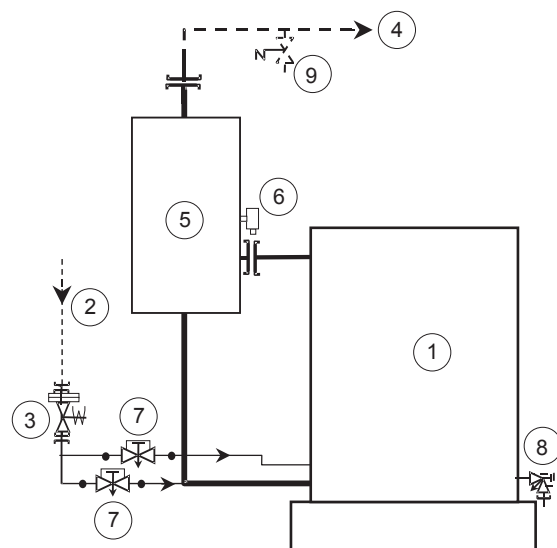

Refrigeration diagram F2000 ABF NH3

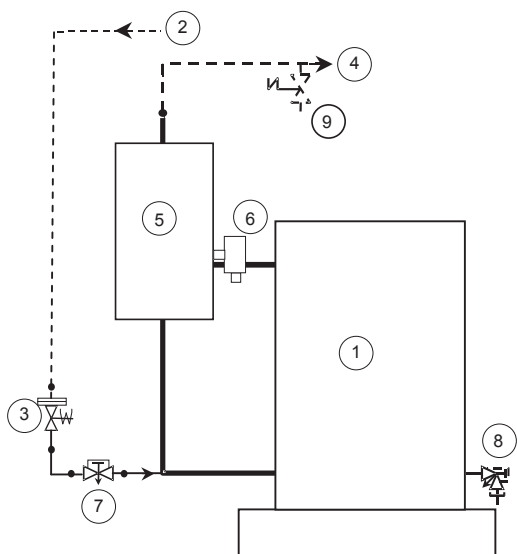

Refrigeration diagram F200 - F250 - F600 ABF NH3

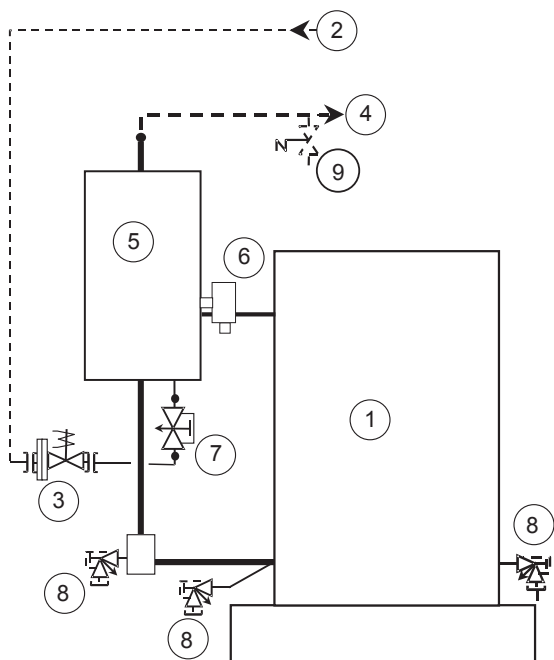

Refrigeration diagram F800 - F900 ABF NH3

Warning

Risk of generator blow out

The value for the Maximum Working Pressure (MWP) is given in the chapter "Safety concerning pressure vessels", like to the plate of identification manufacturer located on the generator.

Appropriate security systems should be set up to avoid pressure building up higher than the MWP, If the generator is likely to be isolated from the rest of the refrigeration circuit by isolation valves :

- A pressure relief valve must be installed to protect the generator.
- The generator must be systematically emptied before these valves are shut.

8.3.3 Oil return device

- R22 - R404a

The oil return device comprises a heat exchanger and a manual valve

During operation only the lower heat exchanger, should be frosted (fully frosted)

See chapter "Refrigerator Diagram"

The manual valve controls the flow rate, and therefore the frosting of the exchangers.



To ensure that the oil return device operates correctly, the temperature of the high pressure liquid entering the generator must be greater than 15°C.

It is possible that a functional problem decreases the flow rate, causing oil to accumulate in the generator; it is possible to drain off this oil through the drain valve on the cylinder.

8.3.4 NH3 oil drain device

- R717

In cooling installations using ammonia, the oil is denser and remains trapped in the generator where it accumulates. This reduces the heat exchange, reduces the production of ice and its quality and affects correct operation of the generator. It is therefore necessary to drain the oil regularly.

Generators operating with ammonia, whether ABF or SBF, include oil drain valves. These may be located at various points on the generator depending on the type. Refer to the chapter 'Cooling Diagrams'.

Important

Repair and maintenance tasks on ammonia systems must be performed by qualified and authorized personnel, in compliance with the applicable standard and legal safety regulations

8.3.4.1 Generators without flood-bottles (SB versions).

Generators are designed to be installed on centralised refrigerating systems with forced recirculation.

The rate of recirculation:

$$\frac{\text{The mass flow of fluid circulating in the generator}}{\text{The mass flow of fluid evaporated}} =$$

Must be between of 3 to 4 (R404A) & 4 to 5 (NH3).

Which means that the mass of fluid circulating in the generator must be between 3 and 5 times greater than evaporated fluid.

The refrigerant flow control valve (throttle), is used to adjust the recirculation flow rate, but can also be used to balance the pressure drop in multi-evaporator circuits with forced circulations.

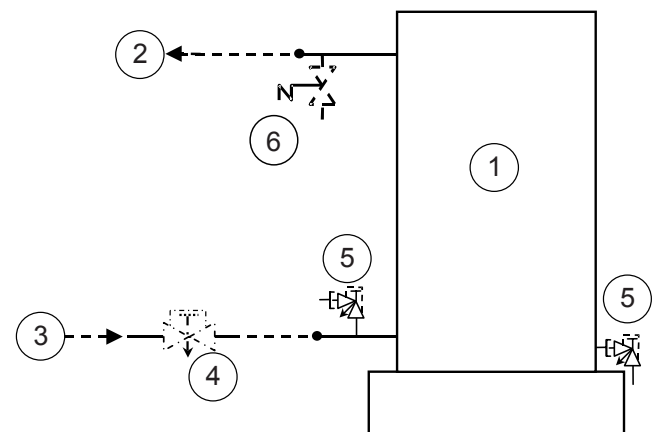

Refrigeration diagram F200 - F250
R404a-NH3-SB versions

| | |
|---|---|
| 1 | Generator |
| 2 | Suction |
| 3 | HP Liquid |
| 4 | Manual throttle |
| 5 | Manual oil drain valve |
| 6 | LP pressure relief valve – (not included) |

generators without flood bottles are designed for use in refrigerated installations already equipped with a suction accumulator.

Evaporators may operate with different evaporating temperatures.

Therefore, it is often necessary to fit a constant pressure valve and maintain the correct suction pressure in the GENEGLACE generator.

9. Operation

9.1 Principle of operation

9.1.1 Description of generator

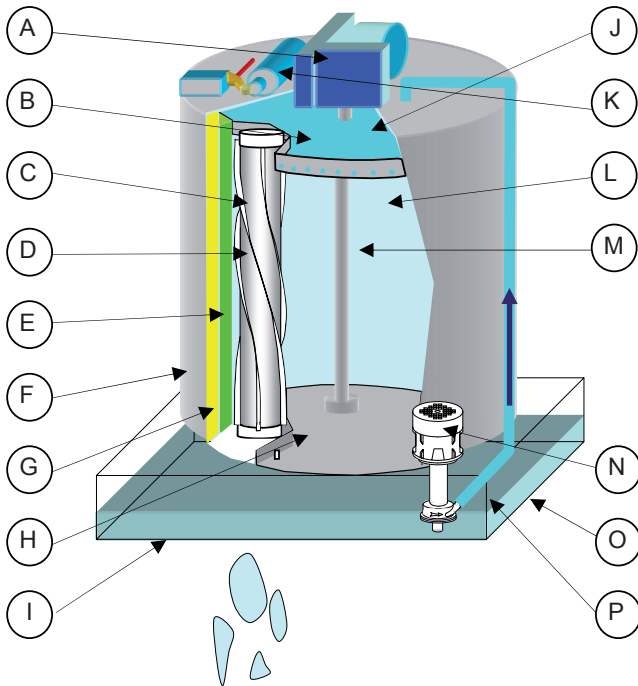

Fig.1 Simplified exploded view of a generator

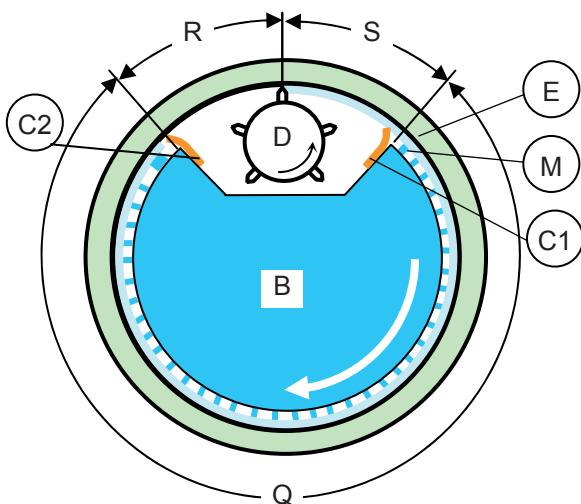

Fig.2 Simplified exploded view of a generator, and an illustration of the water distribution seen from above.

The water distributed by the tank B flows copiously and continuously over the internal surface of the fixed drum F, inside which a refrigerant fluid circulates at low temperature inside the double wall E. The insulation G of the drum ensures heat exchange with the water only.

Part of this water M is frozen and the excess returns via the lower water pan H into the base O, where the level P is kept constant by means of a float valve (not shown). This water is circulated by the pump N.

A helical reamer D, driven through a reduction gear A, sweeps the surface L. When the coat of ice is thick enough, the reamer starts rotating and harvesting the ice by applying pressure on it.

The torque limiter K switches off the electrical supply to the motor-gearbox in the event of mechanical overbad.

The sprayed area Q is bounded by two wipers C1 and C2, which surround the reamer D.

The purpose of wiper C1, situated before the reamer, is to dry the ice before it reaches the subcooling area S. The area R for stripping the ice is located between one tooth of the reamer D and the rear wiper C2.

The purpose of this wiper is to remove the residues of ice which may have remained on the drum after the passage of the reamer. There is no flow of water in the areas R and S. The ice I is stripped in the area R and falls into the storage bin under the machine.

The thickness and quantity of ice produced by the generator depends on :

- The refrigerating power applied to the generator
- The speed of rotation of the reamer.

Important

The thickness of the ice does not depend on the spacing of the reamer from the drum. IT IS DANGEROUS TO SPACE THE REAMER AWAY FROM THE DRUM this can cause: fatigue of the bearings, tripping of the torque limiter, slugging and oil departure that could destroy the compressor.

Note

The reamer speed is set in the factory and cannot be changed without the risk of causing operating problems.

In the factory, the reamer is set as close as possible to the drum : a distance of less than 0.4 mm, for a proper operation.

9.2 Refrigeration operation

The refrigerant fluid circulates freely in the double wall: it is a flooded system.

After expansion, the refrigerant is injected into the lower part of the drum.

The fluid circulates inside the double wall where it changes from a liquid to a gaseous state.

The consequence of this evaporation is to absorb the heat introduced by the water that flows against the inner wall of the drum, where it is frozen.

All the heat is exchanged through the inner wall, and the refrigerant cannot contact the water to be frozen at any time.

The refrigerant is circulated and regenerated by a condenser system.

Important

The refrigerating power applied to the generator must be close to that recommended by GENEGLACE.

Too low or too high a refrigerating power may cause serious malfunctions

In order to ensure trouble-free operation of the ice machine, the flow of expanded refrigerant fluid injected into the generator must be perfectly controlled in order to obtain optimum and constant filling of the generator.

9.2.1 Adjustment of liquid feed

Adjustment of the expansion can be performed only if the refrigerant charge is correct and the condensing pressure is stable and close to average working conditions.

Adjust the injection throttle while checking times of opening and closing of the liquid solenoid valve, so that the opening time for the solenoid valve is at least twice as long as the closing time.

Indirectly, maladjustment of the opening/closing sequences may induce adverse mechanical consequences for the generator itself, as well as for the compressor.

Note

If the refrigerating capacity is oversized, a back pressure valve must be fitted to maintain the desired evaporating temperature.

The following depend directly on correct adjustment of the throttle :

- the filling of the generator with refrigerant fluid and thus the ice production rate.
- the evaporation pressure.
- the suction superheat.
- the return of oil to the compressor.

Important

Set the hand expansion throttle so that the opening time is 2 times greater than the Closing Time (at least).

Too long an opening time in relation to the closing time indicates that the throttle is not open wide-enough.

Too long a closing time in relation to the opening time indicates that the throttle is too wide open.

An opening time which is 5 to 10 times greater than the closing time may indicate a lack of gas.

The correct regulation of the LLC creates the superheat for a proper oil-return.

Excessive superheat causes insufficient filling and trapping of oil inside the cylinder.

Ice production is very much reduced.

Insufficient superheat causes slugging to the compressor.

Important

For the use of any other fluid, consult GENEGLACE.

9.3 Electrical sequences

When starting the ice machine, with the compressor working, only the liquid solenoid valve is open.

After the time delay T1, the water pump and the reamer motor start, the ice machine is then in its normal operating configuration.

T1 = time required after activation of the solenoid valve to fill 75 % of the cylinder with refrigerant

If the torque limiter trips, the solenoid valve, the reamer motor and the water pump stop immediately.

When the torque limiter is reset, the standard start-up procedure is repeated again.

On stoppage of the machine, the water pump and the solenoid valve cut out while the reamer motor continues to rotate for 3 minutes

Time delay T1 : Time required to fill the cylinder with refrigerant before starting production (15s à 180s).

Time delay T2 : 15 to 20 seconds for the R22/R404a circuit with dedicated compressor, 60s for the R717.

Time delay T.KA1 : Time required for cleaning the cylinder after stopping the generator (180s).

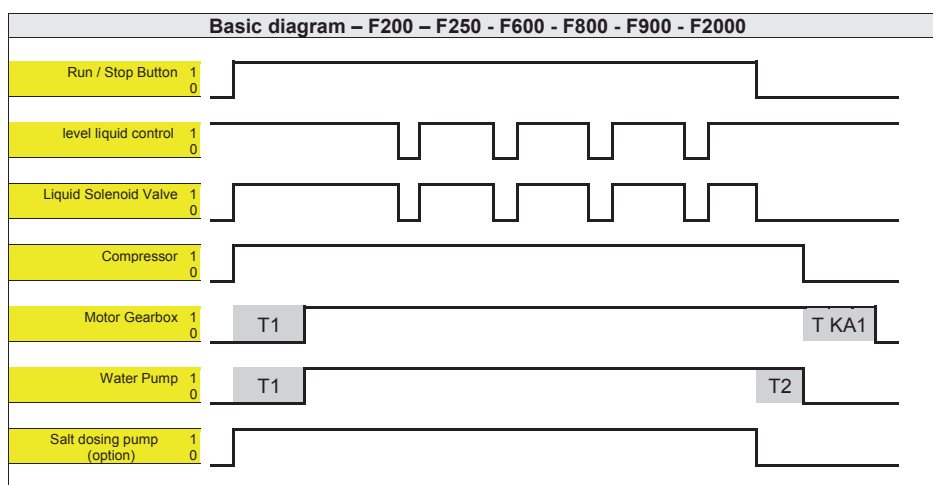

9.3.1 Central refrigerating plant (with one compressor serving several evaporators)

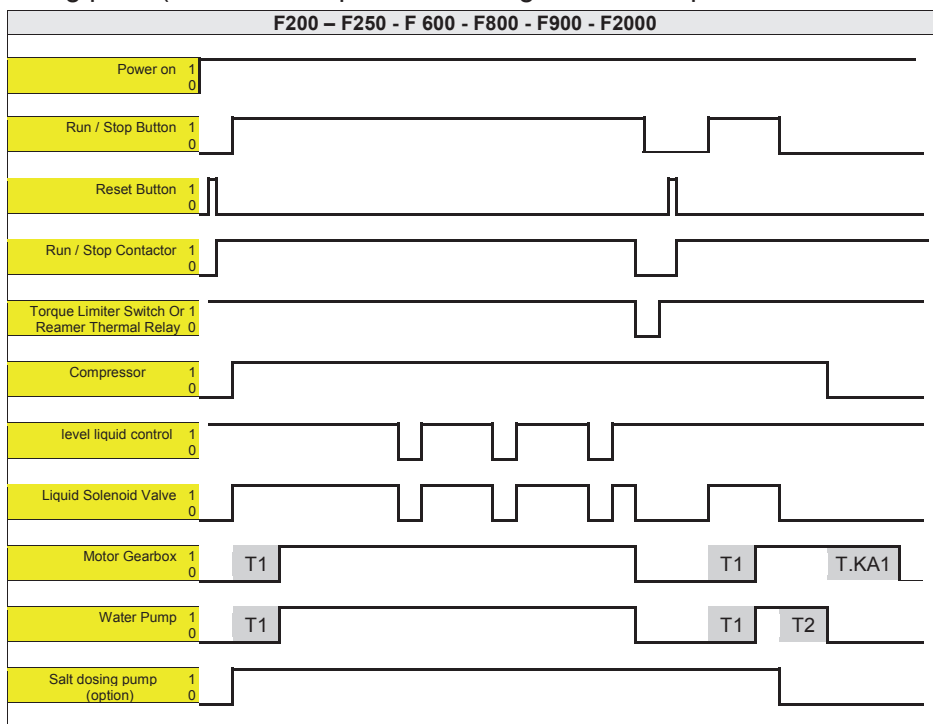
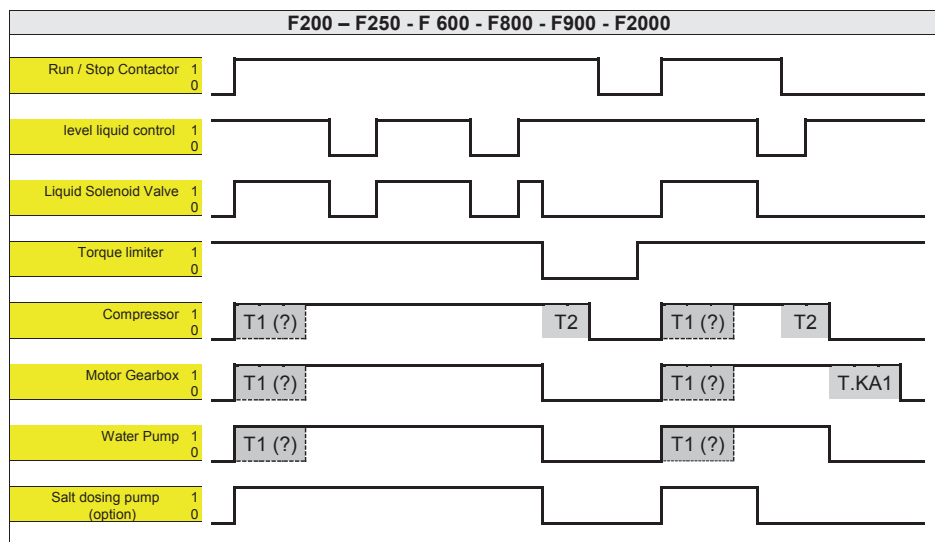

Fig. Sequential diagram for the optional control panel (central refrigerating plant)

Where the salt dosing system includes a dosing pump, its operation will be slaved to that of the liquid solenoid valve.

9.3.2 Refrigerating plant with a dedicated compressor

When starting the ice generator, the compressor, the liquid feed solenoid valve, water pump and reamer motor start simultaneously. If the condensing set is outside there may be a delay of a few seconds before the reamer motor and the pump start. (This is to ensure that at least 3/4 of the height of the generator is frozen at the start). On the diagrams, according to T1 a question mark has (?), this suggests that it is not always necessary to install it, if the condensation unit is near the generator.



9.3.3 Automatic starting and stopping

Ice production can be controlled by a clock. The start time is estimated according to the capacity of the ice bin (500 kg of ice approx.per cubic meter) and the hourly production rate of the machine.

Important

In order to avoid short cycles that could damage your GENEGLACE, the ice level detector switch must be associated with manual or time-delayed resetting.

The electro-mechanical ice level detector (a blade driven by a micro-motor) is the most commonly used. In order to avoid short cycles, also use the terminal box 534004 requiring manual resetting or 534005 permitting resetting with a T3 time delay.

If the ice level detector or the clock cut out, the solenoid valve and the water pump stop immediately while the motor gearbox continues to rotate for 3 minutes

When starting again after such cut-outs, the standard start-up sequences are followed.

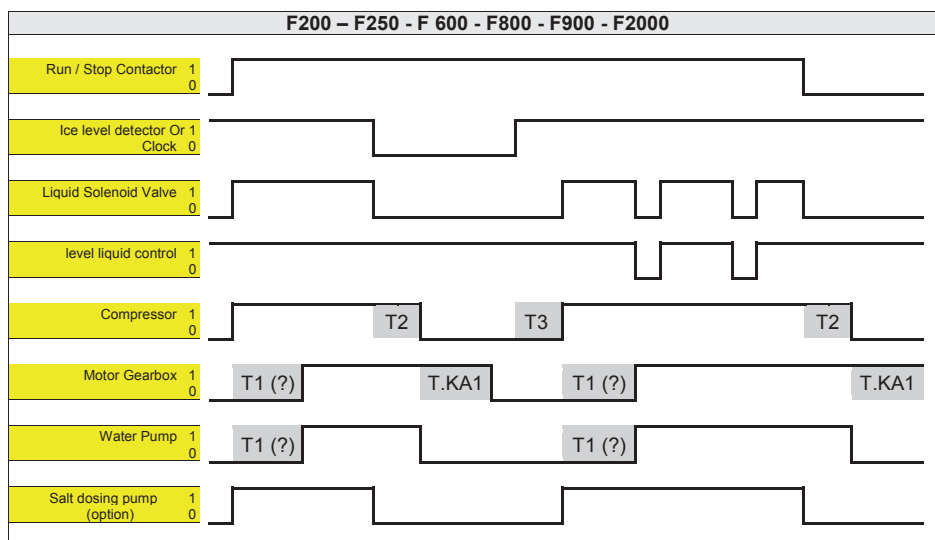

9.4 Operating Parameters F200

| Specifications | | F200 | | | | | | | | | | | | | |
|--|--|--|-------------|-------|--------|--------|--------|-------|-------|--------|--------|-------|-------|--------|--------|
| Units | | R717 : 35(SBF) 15(SBF) / R404A : 40(ABF) 18(SBF) | | | | | | | | | | | | | |
| Fluid load approx.of NH3 / R404A | | NH3 / R404A | | | | | | | | | | | | | |
| Refrigerant | | NH3 | | | | | | | | | | | | | |
| water to be frozen | | 15°C / 59°F | | | | | | | | | | | | | |
| Production | | 4,5 | 5 | 6 | 7 | 7 | 4,5 | 5 | 6 | 7 | 4,5 | 5 | 6 | 7 | |
| Required refrigeration power | | KW | 22,5 | 25 | 30 | 35 | 35 | 22,5 | 25 | 30 | 35 | 22,5 | 25 | 30 | 35 |
| | | BTU/h | 76842 | 85379 | 102455 | 119531 | 119531 | 76842 | 85379 | 102455 | 119531 | 76842 | 85379 | 102455 | 119531 |
| Condensing T° (ABF) | | | | | | | | | | | | | | | |
| Maxi : (Slugging limit) | | °C | 45 | 45 | 45 | 45 | 45 | 60 | 60 | 60 | 60 | 60 | 60 | 60 | 60 |
| | | °F | 113 | 113 | 113 | 113 | 113 | 140 | 140 | 140 | 140 | 140 | 140 | 140 | 140 |
| Mini : (Oil return limit) | | °C | | | | | | 30 | 30 | 30 | 30 | 30 | 30 | 30 | 30 |
| | | °F | | | | | | 86 | 86 | 86 | 86 | 86 | 86 | 86 | 86 |
| Mini HP liquid T° | | °C | 15°C / 59°F | | | | | | | | | | | | |
| | | °F | | | | | | | | | | | | | |
| Frequency of power supply | | Hz | 50 | | | | | | | | | | | | |
| Speed of rotation | | r.p.h | 61 | 74 | 93 | 112 | 112 | 61 | 74 | 93 | 112 | 112 | 61 | 74 | 93 |
| Thickness of ice flakes | | mm | 2,2 | 2 | 1,9 | 1,9 | 1,9 | 2 | 2 | 2 | 2 | 2 | 2 | 1,9 | 2,2 |
| | | inch | 0,09 | 0,08 | 0,07 | 0,07 | 0,07 | 0,08 | 0,08 | 0,08 | 0,08 | 0,08 | 0,08 | 0,07 | 0,09 |
| Evaporation temperature at the generator | | °C | -15,1 | -15,6 | -18,9 | -21,3 | -21,3 | -15,2 | -15,6 | -18,8 | -21,8 | -21,8 | -15,2 | -15,6 | -18,8 |
| | | °F | 4,8 | 3,9 | -2,0 | -6,3 | -6,3 | 4,6 | 3,9 | -1,8 | -7,2 | -7,2 | 4,6 | 3,9 | -1,8 |
| Frequency of power supply | | Hz | 60 | | | | | | | | | | | | |
| Speed of rotation | | r.p.h | *** | 74 | 89 | 113 | 113 | *** | 74 | 89 | 113 | 113 | *** | 74 | 89 |
| Thickness of ice flakes | | mm | *** | 2 | 2 | 1,8 | 1,8 | *** | 2 | 2 | 1,8 | 1,8 | *** | 2 | 1,8 |
| | | inch | *** | 0,08 | 0,08 | 0,07 | 0,07 | *** | 0,08 | 0,08 | 0,07 | 0,07 | *** | 0,08 | 0,07 |
| Evaporation temperature at the generator | | °C | *** | -15,6 | -19,2 | -21,7 | -21,7 | *** | -15,6 | -19,2 | -21,8 | -21,8 | *** | -15,6 | -19,2 |
| | | °F | *** | 3,9 | -2,6 | -7,1 | -7,1 | *** | 3,9 | -2,6 | -7,2 | -7,2 | *** | 3,9 | -2,6 |

9.5 Operating Parameters F250

| Specifications | | F250 | | | | | | | | | | | |
|--|--------|--|--------|--------|--------|--------|--------|--------|--------|--------|--------|--------|--------|
| Fluid load approx. of NH3 / R404A | kg | R717 : 50(ABF) 20(SBF) / R404A : 55(ABF) 30(SBF) | | | | | | | | | | | |
| Refrigerant | | NH3 | | | | | R404A | | | | | | |
| water to be frozen | | 15°C / 59°F | | | | | | | | | | | |
| Production | T /24h | 7 | 8 | 9 | 10 | 7 | 8 | 9 | 10 | 7 | 8 | 9 | 10 |
| Required refrigeration power | KW | 35 | 40 | 45 | 50 | 35 | 40 | 45 | 50 | 35 | 40 | 45 | 50 |
| | BTU/h | 119531 | 136607 | 153683 | 170759 | 119531 | 136607 | 153683 | 170759 | 119531 | 136607 | 153683 | 170759 |
| Condensing T° (ABF) | | | | | | | | | | | | | |
| Maxi : (Slugging limit) | °C | 45 | 45 | 45 | 45 | 57 | 54 | 45 | 33 | | | | |
| | °F | 113 | 113 | 113 | 113 | 135 | 129 | 113 | 91 | | | | |
| Mini : (Oil return limit) | °C | | | | | 30 | 30 | 30 | 30 | | | | |
| | °F | | | | | 86 | 86 | 86 | 86 | | | | |
| Mini HP liquid T° | °C | 15°C / 59°F | | | | | | | | | | | |
| | °F | | | | | | | | | | | | |
| Frequency of power supply | Hz | 50 | | | | | | | | | | | |
| Speed of rotation | r.p.h | 61 | 93 | 93 | 112 | 61 | 93 | 93 | 112 | 61 | 93 | 93 | 112 |
| | mm | 2,6 | 1,9 | 2,1 | 2 | 2,6 | 1,9 | 2,1 | 2 | 2,6 | 1,9 | 2,1 | 2 |
| Thickness of ice flakes | inch | 0,10 | 0,07 | 0,08 | 0,08 | 0,10 | 0,07 | 0,08 | 0,08 | 0,10 | 0,07 | 0,08 | 0,08 |
| | °C | -20,5 | -20 | -23,5 | -25,2 | -20,5 | -20 | -24,3 | -27,7 | | | | |
| Evaporation temperature at the generator | °F | -4,9 | -4,0 | -10,3 | -13,4 | -4,9 | -4,0 | -11,7 | -17,9 | | | | |
| | Hz | 60 | | | | | | | | | | | |
| Speed of rotation | r.p.h | 63 | 89 | 89 | 113 | 63 | 89 | 89 | 113 | 63 | 89 | 89 | 113 |
| | mm | 2,5 | 2 | 2,2 | 2 | 2,5 | 2 | 2,2 | 2 | 2,5 | 2 | 2,2 | 2 |
| Thickness of ice flakes | inch | 0,10 | 0,08 | 0,09 | 0,08 | 0,10 | 0,08 | 0,09 | 0,08 | 0,10 | 0,08 | 0,09 | 0,08 |
| | °C | -20 | -20,5 | -24 | -25,1 | -20,5 | -20,5 | -24,9 | -27,4 | | | | |
| Evaporation temperature at the generator | °F | -4,0 | -4,9 | -11,2 | -13,2 | -4,9 | -4,9 | -12,8 | -17,3 | | | | |

9.6 Operating Parameters F600

| F600 | | | | | | | | | | | | |
|---|--------|--------|--------|--------|--------|--------|-------------|--------|--------|--------|--------|--|
| R717 : 80(ABF) 40(SBF) / R404A : 100(ABF) 60(SBF) | | | | | | | | | | | | |
| NH3 | | | | | | R404A | | | | | | |
| water to be frozen | | | | | | | | | | | | |
| 15°C / 59°F | | | | | | | | | | | | |
| Production | T /24h | 9 | 10 | 11 | 12 | 13 | 9 | 10 | 11 | 12 | 13 | |
| Required refrigeration power | KW | 45 | 50 | 55 | 60 | 65 | 45 | 50 | 55 | 60 | 65 | |
| | BTU/h | 153683 | 170759 | 187835 | 204911 | 221987 | 153683 | 170759 | 187835 | 204911 | 221987 | |
| Condensing T° (ABF) | | | | | | | | | | | | |
| Maxi : (Slugging limit) | °C | 45 | 45 | 45 | 45 | 45 | 55 | 52 | 50 | 44 | 44 | |
| | °F | 113 | 113 | 113 | 113 | 113 | 131 | 126 | 122 | 111 | 111 | |
| Mini : (Oil return limit) | °C | | | | | | 30 | 30 | 30 | 30 | 30 | |
| | °F | | | | | | 86 | 86 | 86 | 86 | 86 | |
| Mini HP liquid T° | °C | | | | | | 15°C / 59°F | | | | | |
| | °F | | | | | | | | | | | |
| Frequency of power supply | Hz | 50 | | | | | | | | | | |
| Speed of rotation | r.p.h | 74 | 74 | 93 | 93 | 112 | 74 | 74 | 93 | 112 | 112 | |
| Thickness of ice flakes | mm | 2 | 2,3 | 2 | 2,2 | 2 | 2,5 | 2,2 | 1,9 | 1,9 | 1,9 | |
| | inch | 0,08 | 0,09 | 0,08 | 0,09 | 0,08 | 0,10 | 0,09 | 0,07 | 0,07 | 0,07 | |
| Evaporation temperature at the generator | °C | -18 | -21 | -21,5 | -24 | -25,5 | -18,5 | -19 | -19,5 | -23 | -23 | |
| | °F | -0,4 | -5,8 | -6,7 | -11,2 | -13,9 | -1,3 | -2,2 | -3,1 | -9,4 | -9,4 | |
| Frequency of power supply | Hz | 60 | | | | | | | | | | |
| Speed of rotation | r.p.h | 74 | 74 | 89 | 89 | 113 | 74 | 89 | 89 | 113 | 113 | |
| Thickness of ice flakes | mm | 2 | 2,3 | 2,1 | 2,3 | 2 | 2 | 1,9 | 2,1 | 1,9 | 1,9 | |
| | inch | 0,08 | 0,09 | 0,08 | 0,09 | 0,08 | 0,08 | 0,07 | 0,08 | 0,07 | 0,07 | |
| Evaporation temperature at the generator | °C | -18 | -21 | -22 | -25 | -25,5 | -18 | -19,5 | -22 | -23 | -23 | |
| | °F | -0,4 | -5,8 | -7,6 | -13,0 | -13,9 | -0,4 | -3,1 | -7,6 | -9,4 | -9,4 | |

9.7 Operating Parameters F800

| F800 | | | | | | | | | | | | | | |
|--|--|---------------|---|--------|--------|--------|--------|--------|--------|--------|--------|--------|------|--|
| Specifications | | Units | | | | | | | | | | | | |
| Fluid load approx.of NH3 / R404A | | kg | R717 : 130(ABF) 85(SBF) / R404A : 180(ABF) 125(SBF) | | | | | | | | | | | |
| Refrigerant | | | NH3 | | | | | | R404A | | | | | |
| water to be frozen | | | 15°C / 59°F | | | | | | | | | | | |
| Production | | T /24h | 13 | 14 | 15 | 16 | 17 | 18 | 13 | 14 | 15 | 15,5 | | |
| Required refrigeration power | | KW | 65 | 70 | 75 | 80 | 85 | 90 | 65 | 70 | 75 | 77,5 | | |
| | | BTU/h | 221987 | 239063 | 256138 | 273214 | 290290 | 307366 | 221987 | 239063 | 256138 | 264676 | | |
| Condensing T° (ABF) | | | | | | | | | | | | | | |
| Maxi : (Slugging limit) | | °C | 45 | 45 | 45 | 45 | 45 | 45 | 55 | 52 | 48 | 45 | | |
| | | °F | 113 | 113 | 113 | 113 | 113 | 113 | 131 | 126 | 118 | 113 | | |
| Mini : (Oil return limit) | | °C | | | | | | | | | | | | |
| | | °F | | | | | | | | | | | | |
| Mini HP liquid T° | | °C | | | | | | | | | | | | |
| | | °F | 15°C / 59°F | | | | | | | | | | | |
| 50 | | | | | | | | | | | | | | |
| Frequency of power supply | | Hz | | | | | | | | | | | | |
| Speed of rotation | | r.p.h | 62 | 62 | 77 | 77 | 77 | 77 | 93 | 50 | 62 | 77 | 77 | |
| Thickness of ice flakes | | mm | 2,1 | 2,2 | 1,9 | 2 | 2,2 | 1,9 | 2,5 | 2,2 | 1,9 | 2 | | |
| | | inch | 0,08 | 0,09 | 0,07 | 0,08 | 0,09 | 0,07 | 0,10 | 0,09 | 0,07 | 0,08 | | |
| Evaporation temperature at the generator | | °C | -17 | -20 | -19 | -21 | -22,5 | -22,5 | -22,5 | -18,5 | -19 | -19,5 | -21 | |
| | | °F | 1,4 | -4,0 | -2,2 | -5,8 | -8,5 | -8,5 | -1,3 | -2,2 | -3,1 | -5,8 | | |
| 60 | | | | | | | | | | | | | | |
| Frequency of power supply | | Hz | | | | | | | | | | | | |
| Speed of rotation | | r.p.h | 60 | 74 | 74 | 74 | 74 | 74 | 93 | 60 | 74 | 74 | 74 | |
| Thickness of ice flakes | | mm | 2,1 | 1,9 | 2 | 2,1 | 2,3 | 1,9 | 2,1 | 2,1 | 1,9 | 2 | 2,1 | |
| | | inch | 0,08 | 0,07 | 0,08 | 0,08 | 0,09 | 0,07 | 0,08 | 0,08 | 0,07 | 0,08 | 0,08 | |
| Evaporation temperature at the generator | | °C | -17 | -18 | -19,5 | -21 | -23 | -22,5 | -22,5 | -17 | -18 | -20 | -21 | |
| | | °F | 1,4 | -0,4 | -3,1 | -5,8 | -9,4 | -8,5 | -8,5 | 1,4 | -0,4 | -4,0 | -5,8 | |

9.8 Operating Parameters F900

| F900 | | | | | | | | | | | | |
|--|--------|--------|--------|--------|--------|--------|--------|--------|--------|--------|--------|--|
| R717 : 200(ABF) 100(SBF) / R404A : 260(ABF) 145(SBF) | | | | | | | | | | | | |
| Refrigerant | | | | | | | | | | | | |
| NH3 | | | | | | | | | | | | |
| R404A | | | | | | | | | | | | |
| water to be frozen | | | | | | | | | | | | |
| 15°C / 59°F | | | | | | | | | | | | |
| Production | T /24h | 19 | 20 | 22 | 24 | 25 | 27 | 17 | 19 | 21 | 23 | |
| Required refrigeration power | KW | 95 | 100 | 110 | 120 | 125 | 135 | 85 | 95 | 105 | 115 | |
| | BTU/h | 324442 | 341518 | 375670 | 409821 | 426897 | 461049 | 290290 | 324442 | 358594 | 392746 | |
| Condensing T° (ABF) | | | | | | | | | | | | |
| Maxi : (Slugging limit) | °C | 45 | 45 | 45 | 45 | 45 | 45 | 55 | 55 | 54 | 48 | |
| | °F | 113 | 113 | 113 | 113 | 113 | 113 | 131 | 131 | 129 | 118 | |
| Mini : (Oil return limit) | °C | | | | | | | 30 | 30 | 30 | 30 | |
| | °F | | | | | | | 86 | 86 | 86 | 86 | |
| Mini HP liquid T° | | | | | | | | | | | | |
| 15°C / 59°F | | | | | | | | | | | | |
| Frequency of power supply | | | | | | | | | | | | |
| 50 | | | | | | | | | | | | |
| Speed of rotation | Hz | 62 | 77 | 77 | 93 | 93 | 93 | 62 | 77 | 77 | 93 | |
| | r.p.h | | | | | | | | | | | |
| Thickness of ice flakes | mm | 2,3 | 2 | 2,2 | 1,9 | 2 | 2,2 | 2,1 | 1,9 | 2 | 1,9 | |
| | inch | 0,09 | 0,08 | 0,09 | 0,07 | 0,08 | 0,09 | 0,08 | 0,07 | 0,08 | 0,07 | |
| Evaporation temperature at the generator | °C | -19 | -18 | -20 | -21,5 | -23 | -26 | -17,5 | -17,5 | -19,5 | -21,5 | |
| | °F | -2,2 | -0,4 | -4,0 | -6,7 | -9,4 | -14,8 | 0,5 | 0,5 | -3,1 | -6,7 | |
| Frequency of power supply | | | | | | | | | | | | |
| 60 | | | | | | | | | | | | |
| Speed of rotation | Hz | 74 | 74 | 74 | 93 | 93 | 93 | 60 | 74 | 74 | 93 | |
| | r.p.h | | | | | | | | | | | |
| Thickness of ice flakes | mm | 1,9 | 2 | 2,2 | 1,9 | 2 | 2,2 | 2,1 | 1,9 | 2,1 | 1,9 | |
| | inch | 0,07 | 0,08 | 0,09 | 0,07 | 0,08 | 0,09 | 0,08 | 0,07 | 0,08 | 0,07 | |
| Evaporation temperature at the generator | °C | -19,5 | -18,5 | -21 | -21,5 | -23 | -26 | -17,5 | -18 | -20 | -21,5 | |
| | °F | -3,1 | -1,3 | -5,8 | -6,7 | -9,4 | -14,8 | 0,5 | -0,4 | -4,0 | -6,7 | |

9.9 Operating Parameters F2000

| | | F2000 | | | | | | | | | |
|--|--------|--|--------|--------|--------|--------|--------|--------|--------|--------|--------|
| Specifications | Units | | | | | | | | | | |
| Fluid load approx.of NH3 / R404A | kg | R717 : 260(ABF) 200(SBF) / R404A : 370(ABF) 270(SBF) | | | | | | | | | |
| Refrigerant | | NH3 | | | | | R404A | | | | |
| water to be frozen | | 5°C / 41°F | | | | | | | | | |
| Production | T /24h | 35 | 40 | 45 | 50 | 30 | 35 | 40 | 45 | 45 | 45 |
| Required refrigeration power | KW | 162 | 185 | 208 | 232 | 139 | 162 | 185 | 208 | 208 | 208 |
| | BTU/h | 553259 | 631808 | 710357 | 792322 | 474710 | 553259 | 631808 | 710357 | 710357 | 710357 |
| Condensing T° (ABF) | | | | | | | | | | | |
| Maxi : (Slugging limit) | °C | 45 | 45 | 45 | 45 | 77 | 53 | 41 | 33 | 33 | 33 |
| | °F | 113 | 113 | 113 | 113 | 171 | 127 | 106 | 91 | 91 | 91 |
| Mini : (Oil return limit) | °C | | | | | 30 | 30 | 30 | 30 | 30 | 30 |
| | °F | | | | | 86 | 86 | 86 | 86 | 86 | 86 |
| Mini HP liquid T° | °C | 15°C / 59°F | | | | | | | | | |
| | °F | | | | | | | | | | |
| Frequency of power supply | Hz | 50 | | | | | | | | | |
| Speed of rotation | r.p.h | 93 | 93 | 122 | 139 | 77 | 93 | 109 | 139 | 139 | 139 |
| Thickness of ice flakes | mm | 1,9 | 2,2 | 1,8 | 1,8 | 2 | 1,9 | 1,8 | 1,6 | 1,6 | 1,6 |
| | inch | 0,07 | 0,09 | 0,07 | 0,07 | 0,08 | 0,07 | 0,07 | 0,07 | 0,06 | 0,06 |
| Evaporation temperature at the generator | °C | -20,1 | -24,1 | -25,3 | -27,8 | -18,2 | -20,9 | -24,6 | -24,6 | -24,6 | -24,6 |
| | °F | -4,2 | -11,4 | -13,5 | -18,0 | -0,8 | -5,6 | -12,3 | -12,3 | -12,3 | -12,3 |
| Frequency of power supply | Hz | 60 | | | | | | | | | |
| Speed of rotation | r.p.h | 93 | 93 | 117 | 148 | 74 | 93 | 111 | 130 | 130 | 130 |
| Thickness of ice flakes | mm | 1,9 | 2,2 | 1,9 | 1,6 | 2 | 1,9 | 1,8 | 1,7 | 1,7 | 1,7 |
| | inch | 0,07 | 0,09 | 0,07 | 0,06 | 0,08 | 0,07 | 0,07 | 0,07 | 0,07 | 0,07 |
| Evaporation temperature at the generator | °C | -20,1 | -24,1 | -26,2 | -26 | -18,2 | -20,9 | -24,6 | -25,8 | -25,8 | -25,8 |
| | °F | -4,2 | -11,4 | -15,2 | -14,8 | -0,8 | -5,6 | -12,3 | -14,4 | -14,4 | -14,4 |

10. Addition of salt

The operation of a flake ice machine is improved by the addition of sodium chloride to the water to be frozen.

Addition of salt :

- delays the formation of scale when hard water is used,
- gives larger flakes, with less breaking up or "snow",
- facilitates ice harvesting and minimises the forces produced by reaction on the reducer.

In short, large flakes of ice are produced with a "smoother" operation.

To add the salt, two methods are proposed :

- the standard dosing system uses calibrated tablets 25 mm in diameter, as employed in water softeners for the regeneration of resins,
- a dosing pump using a solution of purified salt (preferably fine cooking salt) dissolved in water in PVC containers.

100 g of salt is added per tonne of ice, the usual quantity, to be adjusted according to the water quality.

- Ice which is very broken up indicates a lack of salt which is often due to very soft water.
- Ice in very large flakes that can be detached before the passage of the reamer indicates too high a dosage.

Precautions must be taken in the use of these system :

- The tablets used in the standard dosing system must be perfectly cylindrical with at least one flat end so they do not jam in the vertical pipe. The position of the latter must not be altered after filling. Adjustment of the flow rate is possible but requires much care. Monthly cleaning of the base of the dosing system will keep it operating correctly.
- The purified salt used with dosing pumps must be dissolved in small successive quantities to ensure a complete melting, either in cold water or preferably hot water. Final mixing, after complete filling of the PVC tank, will ensure a homogeneous solution.

10.1 The salt dosing tube

A dosing tube is a system for adding salt, mounted in series, in the case where there is no other system available for adding salt. (Generators F200 and F250)

The dosing tube is attached by two collars to the drum of the generator.

It consists of a clear, rigid tube closed at the bottom by a drilled stopper held by a collar.

A small metal tongue collects water from the flow at the base of the drum and conducts it to the dosing tube.

The water collected in this way penetrates between the tube and the stopper of the dosing tube, and comes into contact with the salt tablets.

This procedure generates a steady drip of salt water that passes through the hole in the base n° 3.

The dosing tube is fitted in a corner of the base and positioned so that the base 3 is 125 mm from the bottom of the base and the tongue is directed towards the shaft. The n° 1 hole must engage with the head of the screw of the top collar.

10.1.1 Adjusting the salt dosing tube

By raising base no. 3, or reducing the inclination of the tongue no. 4, the salt consumption is reduced (and conversely).

The dosing tube of the F200 to F250 is provided with an orifice located in front of the tongue which by uncovering it increases the consumption of salt (and conversely).

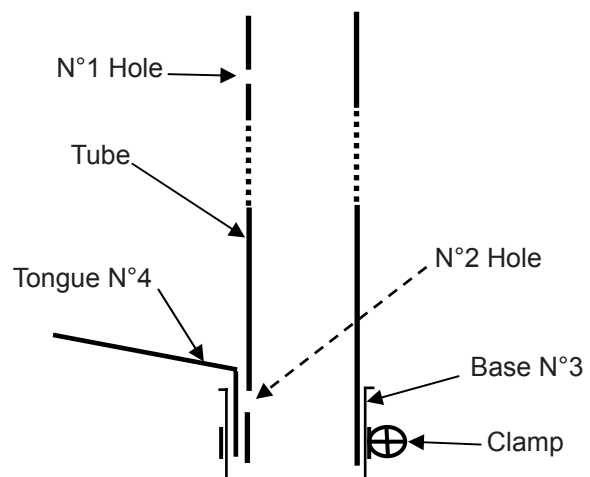

10.2 The dosing pump

Thank to refer to the manual NOT- PDS-K50-2L / h - 02 933 070 attached with the dosing pump.

In the case where the machine is equipped with a salt dosing tube, the dosing pump is not provided.

The dosing pump must operate during ice production.

The electrical characteristics are the following:

- Electrical supply 100÷240 Vac - 50/60 Hz - 15W
- Flow : 0.1% x 2L/h.
- IP65
- Fuse 1,6A (20W).

11. Initial start up

This section gives the chronological order of the checks and actions to be carried out before, during and after the initial start up of your GENEGLACE in complete safety. This is why, before operation of your GENEGLACE, we invite you to refer to the recommendations suggested in this section, by ticking the boxes corresponding to the checks you carry out. Refer to chapter "Commissioning Check List".

Tip

At the first start up, submerge the float to obtain a water level close to the overflow, in order to assist priming of the pump.

11.1 Checks and adjustments

11.1.1 Hydraulics

- Ensure that the water flow rate is greater than the quantity of water required for maximum production of your GENEGLACE and that the water quality is as required.
- Check that the water supply pressure of your machine lies between 2 and 4 bar.
- Check, by pressing on the valve float, that water is reaching the base.

11.1.1.1 Presetting the float valve

The level must be sufficient to prevent cavitation of the pump through lack of water on the one hand and to prevent water overflow on the other hand.

| Water level in the "base" | F200 F250 F600 | | F800 F900 F2000 | |
|---------------------------|----------------------|------|-----------------------|------|
| | mm | Inch | mm | Inch |
| Maximum shut-off level | 95 | 3,74 | 140 | 5,51 |
| Minimum operating level | 75 | 2,95 | 100 | 3,94 |

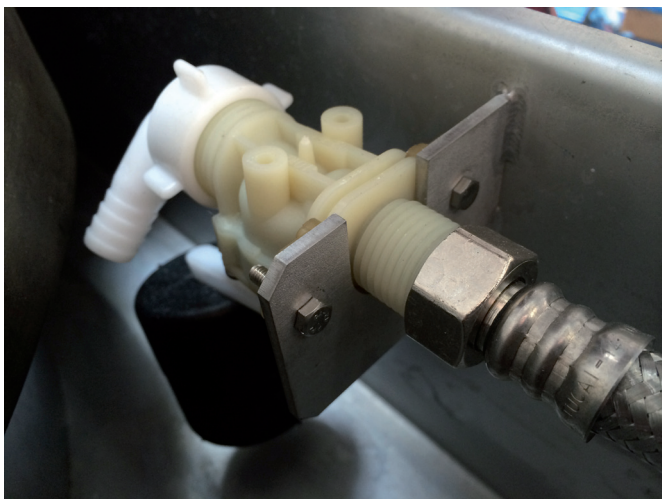

Important

To the running, as stopped, the water level should never submerged the overflow of the water base.

11.1.1.2 Levels of water inside the upper water pan

For F200, F250 and F600 generators, the water level in the upper water distribution pan is obtained by adjusting the restrictors located on the discharge hose of the water pumps.



For the F800 - 900 and F2000, this is obtained by the valve located on the water pump (1 or 2 depending on the model) In order to check the water level, power the water pump only.

- The water level should be at least as indicated here- under and at max one mm below the dent in the top of the upper water tray.

the deicing tube must be submerged

Correct level : minimum 35 mm F200 to F600
50 mm F800 to F2000

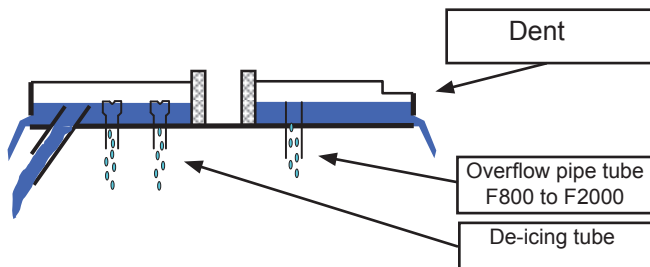

2 adjustable de-icing tubes are fitted to the F200 & F250 and 4 on the F600. 3 overflow pipes of which 2 are adjustable on the F800 and F900 and 4 overflow pipes of which 3 are adjustable on the F2000. On all generators the pan has a rear, non adjustable, rubber wiper de-icing pipe which must be continuously fed with water.

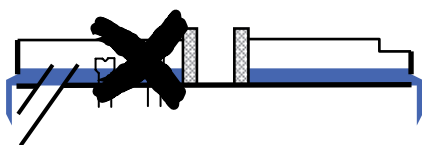

Level is too low : check pump flow rate

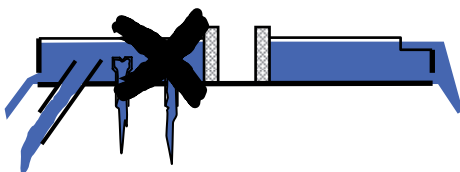

If the water level in the distribution pan is much too high, check the holes in the pan and look for blocked holes.

11.1.2 Electrical system

First insure that the water pump is in good working order.

- Adjust all the circuit breakers to the values corresponding to the nominal current consumed by their respective motors.
- Adjust or preset the time delays.
Checking the reducer motor :
- Check that the motor is correctly coupled.
Energise the motor from a separate supply and check :
- that the direction of rotation of the rotating parts is the same as that shown by the arrow marked on the top of the generator.
- that the speed of rotation of the reducer corresponds to the production rate of the machine (see "Operating parameters").

Note

The speed of the reducer is the number of complete revolutions made by all the rotating parts in one hour.

- At the same time, check the operation of the torque limiter by causing it to trip.

For this it is sufficient to operate the torque limiter by actuating the trackwheel of the electrical torque limiter switch. To reset the limiter, pull the reset button.



Check the operation of the emergency stop button of the torque limiter

□ Adjustment of liquid level control.

Vibrating fork liquid level detector version :

Mode switch

Put the switch indicator in the side of the fonction Dry on ».

Switching delay

Put the switch indicator in front of the 3 secondes

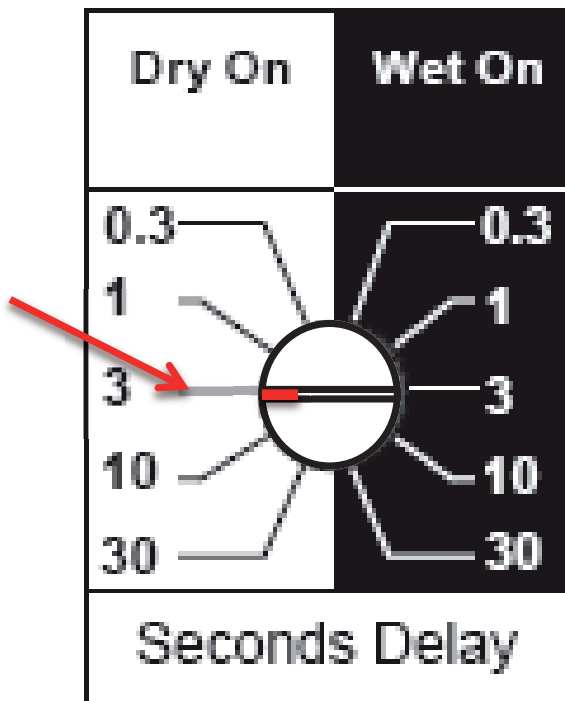

LED indication

| | LED Flash Rate | Switch Status |
|--|-------------------|---|
| | Continuous | Output state is on |
| | 1 every second | Output state is off |
| | 1 every 2 seconds | Uncalibrated |
| | 1 every 4 seconds | Load fault; load current too high; load short circuit |
| | 2 times / second | Indication of successful calibration |
| | 3 times / second | Internal fault (micro, ROM, or RAM) |
| | Off | Problem (e.g. supply) |

Magnetic test point

A magnetic test point is on the side of the housing allowing a functional test. By touching a magnet on the target the 2120 output will change state for as long as the magnet is present

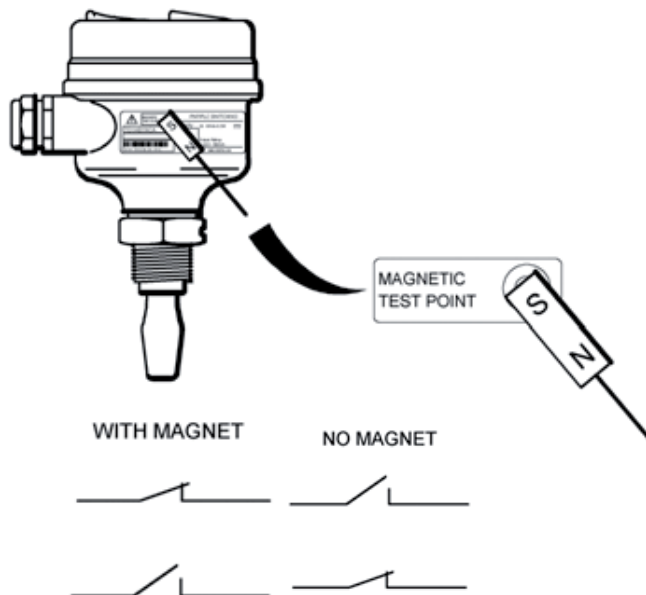

Niveau haut / SEC = ACTIVÉ

| <table border="1"> <tr> <th>Dry On</th> <th>Wet On</th> </tr> <tr> <td>0.3</td> <td>0.3</td> </tr> <tr> <td>1</td> <td>1</td> </tr> <tr> <td>3</td> <td>3</td> </tr> <tr> <td>10</td> <td>10</td> </tr> <tr> <td>30</td> <td>30</td> </tr> <tr> <td colspan="2">Seconds Delay</td> </tr> </table> | | Dry On | Wet On | 0.3 | 0.3 | 1 | 1 | 3 | 3 | 10 | 10 | 30 | 30 | Seconds Delay | |
|---|-----------------------------------|--------|--------|---|-----|---|----|---|---|----|----|----|----|---------------|--|
| Dry On | Wet On | | | | | | | | | | | | | | |
| 0.3 | 0.3 | | | | | | | | | | | | | | |
| 1 | 1 | | | | | | | | | | | | | | |
| 3 | 3 | | | | | | | | | | | | | | |
| 10 | 10 | | | | | | | | | | | | | | |
| 30 | 30 | | | | | | | | | | | | | | |
| Seconds Delay | | | | | | | | | | | | | | | |
| | | | | | | | | | | | | | | | |
| <table border="1"> <tr> <td>NC</td> <td>C</td> <td>NO</td> </tr> </table> | NC | C | NO | <table border="1"> <tr> <td>NC</td> <td>C</td> <td>NO</td> </tr> </table> | NC | C | NO | | | | | | | | |
| NC | C | NO | | | | | | | | | | | | | |
| NC | C | NO | | | | | | | | | | | | | |
| | | | | | | | | | | | | | | | |
| LED allumée continuellement | LED clignote une fois par seconde | | | | | | | | | | | | | | |

Float ball liquid level detector version :

Ensure that the isolation valves of the detector are fully open.

11.1.3 Refrigerating checks

11.1.3.1 Before initial start up

- Ensure for leaks in the refrigerating system.
- In the case of an independent refrigerating system, ice generator connected to a dedicated compressor, the quantity of fluid in the generator is indicated in the section ("Safety concerning pressure vessels"). The installer must provide the charge for the remainder of the system.
- Ensure that the liquid level control is powered
- Fill the generator with refrigerant fluid, filling the solenoid valve separately.
- In the case of an ABF generator (With Flood Bottle), open the manual liquid injection throttle by about 3 turns for the R404A and 1 turn for the NH3.
- Opening the R404A oil return throttle by 1 to 2 turns.

11.1.3.2 Starting your ice machine

- Check that the starting procedure of your GENEGLACE is carried out as described in the section "Diagram of operation".
 - Check that the distribution tank is correctly filled with water.
 - Ensure the proper refrigerant charge
 - Adjust the constant pressure valve to the reference inlet pressure for your GENEGLACE (in the case of connection to a control unit).
 - Adjust the injection throttle to obtain an opening time (at least) 2 times greater than the closing time for R404A - R717. Check the opening and closing times of the liquid solenoid valve.
 - Check the correct return of oil to the compressor (in the case of an independent system).
- Frost level on oil exchangers :

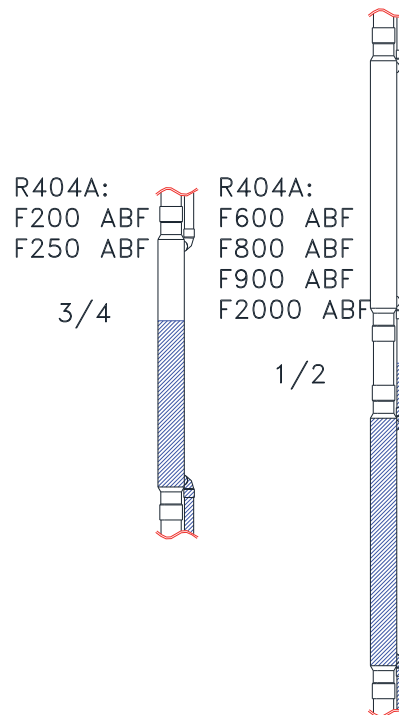

- After a few minutes of operation, check that ice is forming over the full height of the drum associated with the reamer.

If this is not the case, see the section "Faults".

11.1.4 Other checks

- Check that the ice is stripped correctly. If after a few minutes of operation the generator makes a significant noise when the ice is stripped and the ice has difficulty in releasing itself, see sections "Failure and Addition of salt".
- Check that the wipers are performing their function (adjustment, no water flowing into the ice store). To adjust the wipers see section "Adjusting the wipers".

9.1.4.1 Addition of salt

- If required, adjust the salt dosage. See section "Addition of salt".
- Check that the salt addition system is operating correctly.

11.2 Recommended uses

In the case of an independent refrigerating system, leave the power supply of the system switched on during periods of stoppage : the crankcase heater must remain live.

In the same case, after a long period without electrical power, power on at least 3 hours before starting-up.

Avoid short duration run and stop periods. It is preferable to leave the machine operating for 4 hours rather than short-cycling it 4 times 1 hour on and 1 hour off.

During prolonged stoppages (more than a week), it is advisable to run the machine for 1 hour without adding salt and to drain and dry the base.

Management of a stock of ice :

The basis for calculating the effective volume is : 500 kg about of freshly flaked ice to 1m³.

To keep the ice fresh, do not keep it for more than 2 days.

The ice storage container must be emptied at least once a week so that the user has no difficulty in extracting the ice. There is also a risk of damage to the GENEGLACE, by a build-up of ice in the generator.

11.3 Start-up report

A start-up report at the initial start up will :

- enable you to check the correct operation of your installation by noting a few important points of operation.

- Open all right for warranty.

You will find an initial start up report at the end of this notice, it has four headings.

- Points to note : description of the inspection or check to be carried out.

- Values : generally a physical quantity to be measured and entered or a box to be ticked as checked.

- Where to note : the exact location of the note or check to be made in relation to the fluid diagram attached to the note.

- How to note : for the purpose of helping you to make the most accurate note possible by means of a precise procedure.

12. Commissioning Check List

Before Start-up, refer to the safety instructions and further recommendations in the installer manual



The aim of this checklist is to check the main steps of the installation of a generator in view of the latter's good working order.

Tick the boxes as the check proceeds



1. Before turning the power on, check:

- | | |
|--|--------------------------|
| That the water tray base is fixed properly and watertight (flat and level surface) | <input type="checkbox"/> |
| The sealing of the water tray base on its support (<i>silicone seal around the ice outlet</i>) | <input type="checkbox"/> |
| The diameter of the ice chute (<i>where appropriate</i>) (<i>according to instructions</i>) | <input type="checkbox"/> |
| That it is possible to remove the ice chute for future maintenance | <input type="checkbox"/> |
| That the ice chute is not in the flow of air of an evaporator | <input type="checkbox"/> |
| The opening of the 2 hand valves on either side of the expansion valve | <input type="checkbox"/> |
| The opening (1 - 2 turns) of the oil drain throttle R22 – R404a | <input type="checkbox"/> |
| Opening the shut-off valves from LLC to R717 | <input type="checkbox"/> |
| Opening the injection throttle to R717 by 1 turn | <input type="checkbox"/> |
| That the oil drain inlet is correctly set up on the suction tube | <input type="checkbox"/> |
| The position of the bulb of the expansion valve (<i>according to instructions</i>) and the insulation thereof | <input type="checkbox"/> |
| The connection to the overflow tube | <input type="checkbox"/> |
| The flow regulation of the water float valve (<i>at standstill</i>) (<i>according to instructions</i>) | <input type="checkbox"/> |
| That the water float valve has remained in operating position after having been connected (<i>according to instructions</i>) That the water float ball has freedom of movement | <input type="checkbox"/> |
| The level of water in the water tray base of the generator at standstill (<i>according to instructions</i>) | <input type="checkbox"/> |
| The positioning of the salt doser (<i>where appropriate</i>) (<i>according to instructions</i>) | <input type="checkbox"/> |
| The installation of the dosing pump (<i>where appropriate</i>) (<i>according to instructions</i>) | <input type="checkbox"/> |
| Prepare the brine container with fine salt (<i>if a metering pump is installed</i>) | <input type="checkbox"/> |
| The connection of the reducer motor | <input type="checkbox"/> |
| The electrical connection of the torque limiter | <input type="checkbox"/> |
| The electrical connection from LLC to R71 | <input type="checkbox"/> |
| The presence of a <u>temporised</u> pump down to be adjusted | <input type="checkbox"/> |
| The presence of a “working” timer (delay at interlock) on the reducer and water pump control (if the generator is connected to a central refrigeration system) | <input type="checkbox"/> |
| The presence of an “idle” timer (delay at downtime) on the reducer motor control | <input type="checkbox"/> |

2. After turning the power on:

- Manually activate the torque limiter then rearm it (*red lever*),
(according to instructions) (complete standstill of the generator and generating set unit)
- Check the direction of rotation of the reducer (*refer to the arrow painted on the upper part – clockwise*)
- Check the working order and the adjustment of the dosing pump (*where relevant*)
- Set the "work" timer to between 0 and 15 s if the machine is connected to a power station,
then set the reducer motor timer to 180 s.
- Preload the refrigerating circuit after vacuumizing
- Ensure that the LLC is operational (on / off) R717

3. After commissioning:

- After having turned on the liquid solenoid valve, time the filling time of the *cylinder*
(see suction outlet icing) (connection to central system)
- Transfer this time to the "working" timer (*adjust value if need be*)
- The commissioning of the reamer and pump after timer
- Adjusting the evaporating pressure reducer (*where relevant*)
(in order to obtain the pressure recommended by GENEGLACE at the time of the order)
- Set the expansion valve to 6/8K with reference to the bulb
(bulb temperature minus evaporating temperature)
- Adjusting the rubber wipers (*according to instructions*)
- The level of water in the upper tray and that of the water tray base (*according to instructions*)
- The oil level at compressor indicator (*to be monitored also later*)

4. After 10 - 15 minutes operation, check:

- The level of water in the water tray base (*according to instructions*)
(that no water drains out of the overflow)
- Removal of the ice without the reducer motor moving
- Spraying of water droplets on the strip of the salt doser (*where relevant*)
- The drip of the dosing pump (*where relevant*)
- Set the injection adjuster so that the opening time is twice as long as the closing time (at least) R717
- The icing of approximately 3/4 of the exchanger on the oil drain line (*set regulator*) R22 – R404a
- The feedback of the oil level to the compressor indicator (*according to the type of installation, extra oil may be required*)
- The operating pressures (*according to defined production*)
- Stop the generator with the I.L.D (check if installed), then the Stop button., check the level of water
in the water tray base (*according to instructions*) (check to make sure that no water drains out of the overflow)
- Re-commission the installation and fill in the operation report sheet

13. Operational Measurement sheet - (R22 - R404a)

| CHECK LIST : INITIAL START UP | | | |
|--------------------------------------|--|-------------|--|
| GENEGLACE TYPE | <input style="width: 90%;" type="text"/> | USER | <input style="width: 90%;" type="text"/> |
| ICE MAKER SERIAL NUMBER | <input style="width: 90%;" type="text"/> | CUSTOMER | <input style="width: 90%;" type="text"/> |
| TESTING DATE | <input style="width: 20%;" type="text"/> / <input style="width: 20%;" type="text"/> / <input style="width: 20%;" type="text"/> | FILE NUMBER | <input style="width: 90%;" type="text"/> |

Check the calibration of the tools before the operation.

| Check points | Data | Where to check | How to check |
|--------------|------|----------------|--------------|
|--------------|------|----------------|--------------|

| GENERATOR | | | | | | | | | | | | | | | | | | | | | | | | | | | |
|---|---|--|---|--------------------------|---------------------|---|--|--|--|--|---|--|--|--|------------------|--|--|--|----------------|--|--|--|--------------------|--|--|----------|---|
| Refrigerant type | <input style="width: 90%;" type="text"/> | A | Read on the GENEGLACE identification plate. | | | | | | | | | | | | | | | | | | | | | | | | |
| Voltage supply of the generator | <table border="1" style="width: 100%; border-collapse: collapse;"> <tr> <td style="width: 33%;">Ph 1-2</td> <td style="width: 33%;">Ph 1-3</td> <td style="width: 33%;">Ph 2-3</td> </tr> <tr> <td style="text-align: center;">V</td> <td style="text-align: center;">V</td> <td style="text-align: center;">V</td> </tr> </table> | Ph 1-2 | Ph 1-3 | Ph 2-3 | V | V | V | Z | Measure the voltage on the terminal of the electrical control panel. | | | | | | | | | | | | | | | | | | |
| Ph 1-2 | Ph 1-3 | Ph 2-3 | | | | | | | | | | | | | | | | | | | | | | | | | |
| V | V | V | | | | | | | | | | | | | | | | | | | | | | | | | |
| Water supply | <table style="width: 100%;"> <tr> <td style="width: 20%;">base tray</td> <td style="width: 60%;"><input style="width: 90%;" type="text"/></td> <td style="width: 20%; text-align: right;">mm</td> </tr> <tr> <td>upper tray</td> <td><input style="width: 90%;" type="text"/></td> <td style="text-align: right;">mm</td> </tr> </table> | base tray | <input style="width: 90%;" type="text"/> | mm | upper tray | <input style="width: 90%;" type="text"/> | mm | B | Measure the water level in the upper water tray and in the water base, when operating the machine. | | | | | | | | | | | | | | | | | | |
| base tray | <input style="width: 90%;" type="text"/> | mm | | | | | | | | | | | | | | | | | | | | | | | | | |
| upper tray | <input style="width: 90%;" type="text"/> | mm | | | | | | | | | | | | | | | | | | | | | | | | | |
| Reamer control | <table style="width: 100%;"> <tr> <td style="width: 20%;">upper tray</td> <td style="width: 20%;"><input type="checkbox"/></td> <td style="width: 20%;"><input type="checkbox"/></td> <td style="width: 40%;"></td> </tr> </table> | upper tray | <input type="checkbox"/> | <input type="checkbox"/> | | C | Measure the water level in the upper water tray and in the water base, when operating the machine. | | | | | | | | | | | | | | | | | | | | |
| upper tray | <input type="checkbox"/> | <input type="checkbox"/> | | | | | | | | | | | | | | | | | | | | | | | | | |
| | <table style="width: 100%;"> <tr> <td style="width: 20%;">rotation speed</td> <td style="width: 60%;"><input style="width: 90%;" type="text"/></td> <td style="width: 20%; text-align: right;">Sec/Rnd</td> </tr> </table> | rotation speed | <input style="width: 90%;" type="text"/> | Sec/Rnd | D | Duration of one complete reamer rotation. | | | | | | | | | | | | | | | | | | | | | |
| rotation speed | <input style="width: 90%;" type="text"/> | Sec/Rnd | | | | | | | | | | | | | | | | | | | | | | | | | |
| Temperature of water supply | <input style="width: 90%;" type="text"/> °C | E | Measure the temperature of the water at the outlet of water float valve. Don't measure the temperature inside the base. | | | | | | | | | | | | | | | | | | | | | | | | |
| Ice production | <input style="width: 90%;" type="text"/> kg/H | F | By weighing the ice or by reading of a water flow meter fitted on the water supply pipe. | | | | | | | | | | | | | | | | | | | | | | | | |
| Thickness of ice flakes | <input style="width: 90%;" type="text"/> mm | G | Use a caliper square. The tool must not warm up the ice (preferably use a plastic caliper square). When using a metal caliper square you must precool it. | | | | | | | | | | | | | | | | | | | | | | | | |
| Aspect of the ice flakes | <table border="1" style="width: 100%; border-collapse: collapse;"> <tr> <td style="width: 5%;"></td> <td style="width: 15%;">Dry</td> <td style="width: 15%;"></td> <td style="width: 65%;"></td> </tr> <tr> <td></td> <td>Wet</td> <td></td> <td></td> </tr> <tr> <td></td> <td>Transparent</td> <td></td> <td></td> </tr> <tr> <td></td> <td>White and opaque</td> <td></td> <td></td> </tr> <tr> <td></td> <td>Smooth surface</td> <td></td> <td></td> </tr> <tr> <td></td> <td>Granular on 1 side</td> <td></td> <td></td> </tr> </table> | | Dry | | | | Wet | | | | Transparent | | | | White and opaque | | | | Smooth surface | | | | Granular on 1 side | | | H | By examining the ice at the outlet of the generator (tick appropriate boxes). |
| | Dry | | | | | | | | | | | | | | | | | | | | | | | | | | |
| | Wet | | | | | | | | | | | | | | | | | | | | | | | | | | |
| | Transparent | | | | | | | | | | | | | | | | | | | | | | | | | | |
| | White and opaque | | | | | | | | | | | | | | | | | | | | | | | | | | |
| | Smooth surface | | | | | | | | | | | | | | | | | | | | | | | | | | |
| | Granular on 1 side | | | | | | | | | | | | | | | | | | | | | | | | | | |
| Ice temperature | <input style="width: 90%;" type="text"/> °C | I | Make the measurement during several minutes. | | | | | | | | | | | | | | | | | | | | | | | | |
| Level of ice forming in the generator | | J | Indicate on the drawing : the level of ice forming in the cylinder | | | | | | | | | | | | | | | | | | | | | | | | |
| Temperature of the refrigerant at the outlet of the cylinder | <input style="width: 90%;" type="text"/> °C | K | Use an electronic contact thermometer. Position it on the suction pipe close to the bulb. | | | | | | | | | | | | | | | | | | | | | | | | |
| Control the torque limiter switch | <input type="checkbox"/> | L | Tick the box if the switch is operational. | | | | | | | | | | | | | | | | | | | | | | | | |
| Evaporating pressure | <input style="width: 90%;" type="text"/> bar | N | Read pressure with a manometer at the outlet of the generator. | | | | | | | | | | | | | | | | | | | | | | | | |
| Corresponding temperature | <input style="width: 90%;" type="text"/> °C | N | | | | | | | | | | | | | | | | | | | | | | | | | |
| Condensing pressure | <input style="width: 90%;" type="text"/> bar | O | Read pressure with a manometer at the inlet of the generator. | | | | | | | | | | | | | | | | | | | | | | | | |
| corresponding temperature | <input style="width: 90%;" type="text"/> °C | O | | | | | | | | | | | | | | | | | | | | | | | | | |
| Others controls | | | | | | | | | | | | | | | | | | | | | | | | | | | |
| Timer for the GENEGLACE start | <input style="width: 90%;" type="text"/> Sec | Z | Read the timer value. | | | | | | | | | | | | | | | | | | | | | | | | |
| Timer for the reducer stop | <input style="width: 90%;" type="text"/> Sec | Z | Read the timer value. | | | | | | | | | | | | | | | | | | | | | | | | |
| Timer for the pump down | <input style="width: 90%;" type="text"/> Sec | Z | Read the timer value. | | | | | | | | | | | | | | | | | | | | | | | | |
| Refrigerant connection | <table border="1" style="width: 100%; border-collapse: collapse;"> <tr> <td style="width: 25%;">Height</td> <td style="width: 25%;">Length</td> <td style="width: 25%;">Dia / i</td> <td style="width: 25%;">Dia / o</td> </tr> <tr> <td><input style="width: 90%;" type="text"/></td> <td><input style="width: 90%;" type="text"/></td> <td><input style="width: 90%;" type="text"/></td> <td><input style="width: 90%;" type="text"/></td> </tr> </table> | Height | Length | Dia / i | Dia / o | <input style="width: 90%;" type="text"/> | <input style="width: 90%;" type="text"/> | <input style="width: 90%;" type="text"/> | <input style="width: 90%;" type="text"/> | | Height between the generator and the condensing unit. Length of tube between the generator and the condensing unit. Dia : inlet and outlet diameters of connecting tubes. | | | | | | | | | | | | | | | | |
| Height | Length | Dia / i | Dia / o | | | | | | | | | | | | | | | | | | | | | | | | |
| <input style="width: 90%;" type="text"/> | <input style="width: 90%;" type="text"/> | <input style="width: 90%;" type="text"/> | <input style="width: 90%;" type="text"/> | | | | | | | | | | | | | | | | | | | | | | | | |
| Generator located : | <table style="width: 100%;"> <tr> <td style="width: 20%;"><input type="checkbox"/></td> <td style="width: 80%;">above the condenser</td> </tr> <tr> <td><input type="checkbox"/></td> <td>below the condenser</td> </tr> </table> | <input type="checkbox"/> | above the condenser | <input type="checkbox"/> | below the condenser | - | Tick the appropriate box. | | | | | | | | | | | | | | | | | | | | |
| <input type="checkbox"/> | above the condenser | | | | | | | | | | | | | | | | | | | | | | | | | | |
| <input type="checkbox"/> | below the condenser | | | | | | | | | | | | | | | | | | | | | | | | | | |
| | | - | Tick the appropriate box. | | | | | | | | | | | | | | | | | | | | | | | | |

| | | |
|--|--|---|
| Name of the engineer who performed this test : | <input style="width: 90%;" type="text"/> | signature of the person in charge, and stamp of the company : |
| Name of the person in charge : | <input style="width: 90%;" type="text"/> | |
| Date : | <input style="width: 20%;" type="text"/> / <input style="width: 20%;" type="text"/> / <input style="width: 20%;" type="text"/> | |

13.1 Measurement Points for F200 to F600 Generators

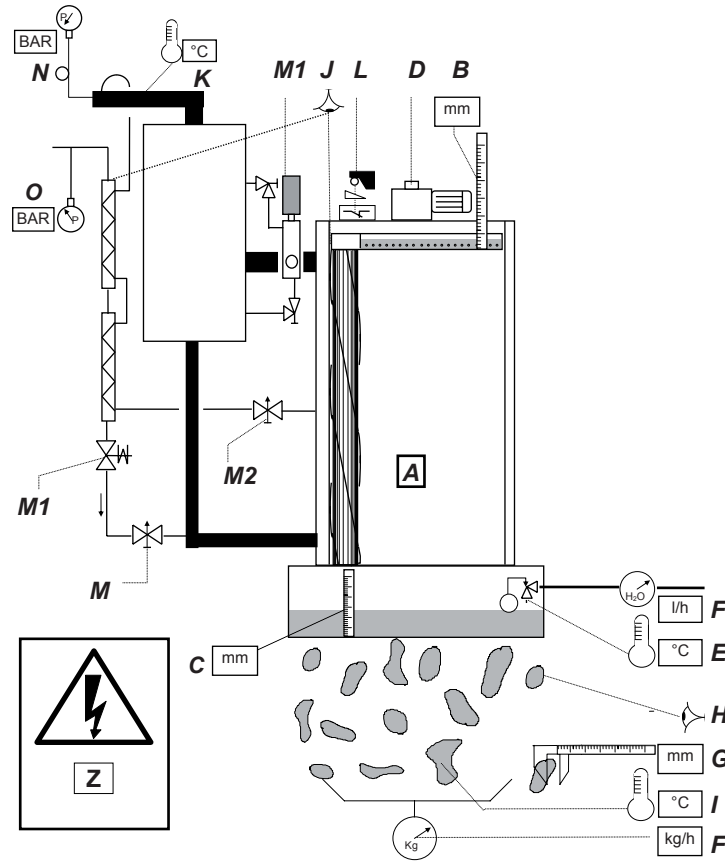

13.2 Measurement Points for F800 and F900 Generators

13.3 Measurement Points for F2000 Generators

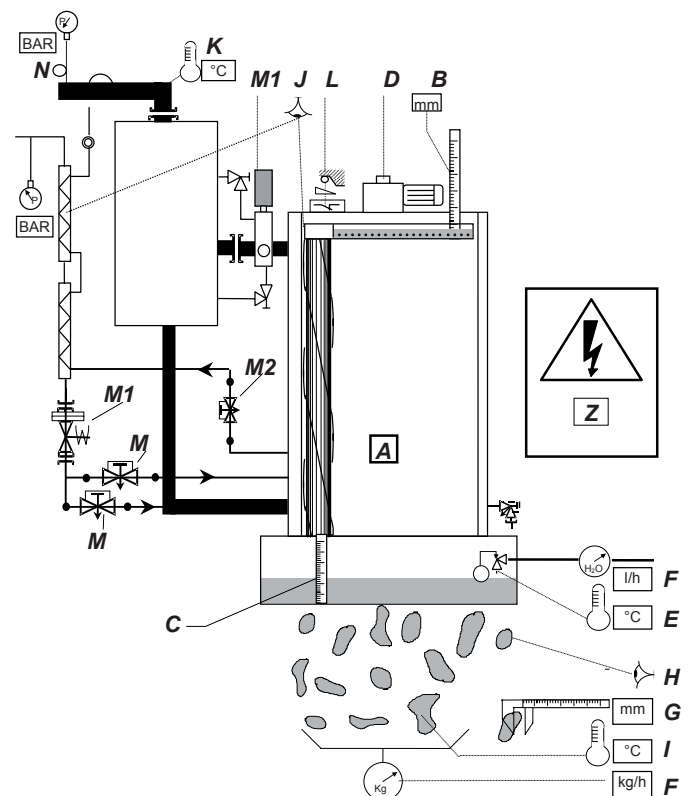
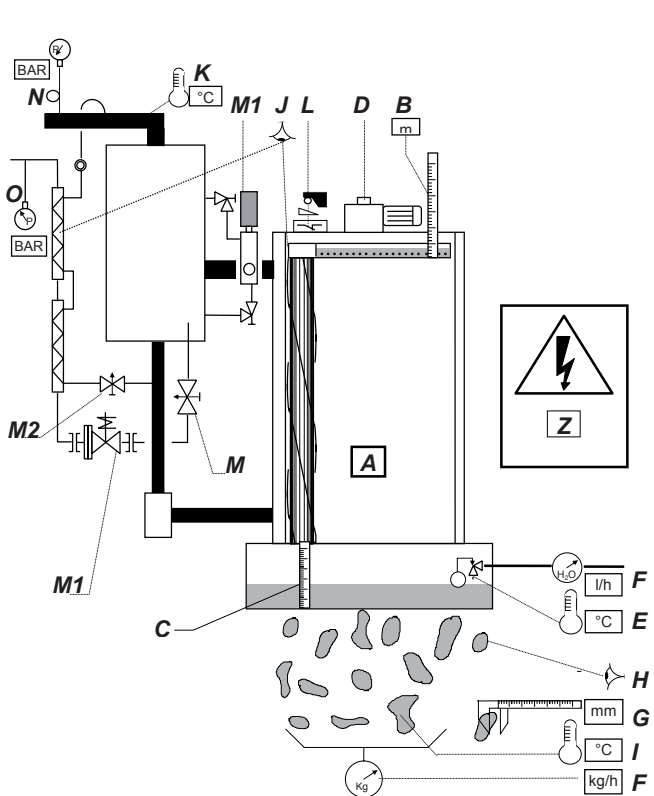

13.4 Operational Measurement sheet NH3

| CHECK LIST : INITIAL START UP | | | |
|--------------------------------------|--|-------------|--|
| GENEGLACE TYPE | <input style="width: 90%;" type="text"/> | USER | <input style="width: 90%;" type="text"/> |
| ICE MAKER SERIAL NUMBER | <input style="width: 90%;" type="text"/> | CUSTOMER | <input style="width: 90%;" type="text"/> |
| TESTING DATE | <input style="width: 25%;" type="text"/> / <input style="width: 25%;" type="text"/> / <input style="width: 25%;" type="text"/> | FILE NUMBER | <input style="width: 90%;" type="text"/> |

Check the calibration of the tools before the operation.

| Check points | Data | Where to check | How to check |
|--------------|------|----------------|--------------|
|--------------|------|----------------|--------------|

GENERATOR

| | | | | | | | | | | | | | | | |
|--|--|--------------------------|--|----------------|---|--------------------------|---|--|---|--|----------------|--|--------------------|--|--|
| Refrigerant type | <input style="width: 90%;" type="text"/> | CF. refrigerating sketch | A Read on the GENEGLACE identification plate. | | | | | | | | | | | | |
| Voltage supply of the generator | <table border="1" style="width: 100%; border-collapse: collapse;"> <tr> <td style="width: 33%;">Ph 1-2</td> <td style="width: 33%;">Ph 1-3</td> <td style="width: 33%;">Ph 2-3</td> </tr> <tr> <td style="text-align: center;"><input type="checkbox"/></td> <td style="text-align: center;"><input type="checkbox"/></td> <td style="text-align: center;"><input type="checkbox"/></td> </tr> </table> | Ph 1-2 | Ph 1-3 | Ph 2-3 | <input type="checkbox"/> | <input type="checkbox"/> | <input type="checkbox"/> | | Z Measure the voltage on the terminal of the electrical control panel. | | | | | | |
| Ph 1-2 | Ph 1-3 | Ph 2-3 | | | | | | | | | | | | | |
| <input type="checkbox"/> | <input type="checkbox"/> | <input type="checkbox"/> | | | | | | | | | | | | | |
| Water supply | <table style="width: 100%;"> <tr> <td style="width: 50%;">base tray</td> <td style="width: 50%; text-align: right;">mm</td> </tr> <tr> <td>upper tray</td> <td style="text-align: right;">mm</td> </tr> </table> | base tray | mm | upper tray | mm | | B Measure the water level in the upper water tray and in the water base, when operating the machine. | | | | | | | | |
| base tray | mm | | | | | | | | | | | | | | |
| upper tray | mm | | | | | | | | | | | | | | |
| Reamer control | <table style="width: 100%;"> <tr> <td style="width: 50%;">upper tray</td> <td style="width: 50%; text-align: center;"> <input style="width: 40%; height: 20px;" type="checkbox"/> <input style="width: 40%; height: 20px;" type="checkbox"/> </td> </tr> </table> | upper tray | <input style="width: 40%; height: 20px;" type="checkbox"/> <input style="width: 40%; height: 20px;" type="checkbox"/> | | C Measure the water level in the upper water tray and in the water base, when operating the machine. | | | | | | | | | | |
| upper tray | <input style="width: 40%; height: 20px;" type="checkbox"/> <input style="width: 40%; height: 20px;" type="checkbox"/> | | | | | | | | | | | | | | |
| | rotation speed | Sec/Rnd | D Tick the box corresponding to the rotating side, seen from the top of the generator. | | | | | | | | | | | | |
| Temperature of water supply | °C | | D Duration of one complete reamer rotation. | | | | | | | | | | | | |
| Ice production | kg/H | | E Measure the temperature of the water at the outlet of water float valve. Don't measure the temperature inside the base. | | | | | | | | | | | | |
| Thickness of ice flakes | mm | | F By weighing the ice or by reading of a water flow meter fitted on the water supply pipe. | | | | | | | | | | | | |
| Aspect of the ice flakes | <table border="1" style="width: 100%; border-collapse: collapse;"> <tr><td style="width: 50%;"></td><td style="width: 50%; text-align: right;">Dry</td></tr> <tr><td></td><td style="text-align: right;">Wet</td></tr> <tr><td></td><td style="text-align: right;">Transparent</td></tr> <tr><td></td><td style="text-align: right;">White and opaque</td></tr> <tr><td></td><td style="text-align: right;">Smooth surface</td></tr> <tr><td></td><td style="text-align: right;">Granular on 1 side</td></tr> </table> | | Dry | | Wet | | Transparent | | White and opaque | | Smooth surface | | Granular on 1 side | | G Use a caliper square. The tool must not warm up the ice (preferably use a plastic caliper square). When using a metal caliper square you must precool it. |
| | Dry | | | | | | | | | | | | | | |
| | Wet | | | | | | | | | | | | | | |
| | Transparent | | | | | | | | | | | | | | |
| | White and opaque | | | | | | | | | | | | | | |
| | Smooth surface | | | | | | | | | | | | | | |
| | Granular on 1 side | | | | | | | | | | | | | | |
| Ice temperature | °C | | H By examining the ice at the outlet of the generator (tick appropriate boxes). | | | | | | | | | | | | |
| Level of ice forming in the generator | | | H H H H H | | | | | | | | | | | | |
| Temperature of the refrigerant at the outlet of the cylinder | °C | | I Make the measurement during several minutes. | | | | | | | | | | | | |
| Control the torque limiter switch | <input type="checkbox"/> | | J Indicate on the drawing : the level of ice forming in the cylinder | | | | | | | | | | | | |
| Control of the injection times | <table style="width: 100%;"> <tr> <td style="width: 50%;">- opening time</td> <td style="width: 50%; text-align: right;">Sec</td> </tr> <tr> <td>- closing time</td> <td style="text-align: right;">Sec</td> </tr> </table> | - opening time | Sec | - closing time | Sec | | K Use an electronic contact thermometer. Position it on the suction pipe close to the bulb. | | | | | | | | |
| - opening time | Sec | | | | | | | | | | | | | | |
| - closing time | Sec | | | | | | | | | | | | | | |
| Evaporating pressure | bar | | L Tick the box if the switch is operational. | | | | | | | | | | | | |
| Corresponding temperature | °C | | M1 Measure the opening and closing times of the liquid level control or of the solenoid valve. | | | | | | | | | | | | |
| Condensing pressure | bar | | M1 | | | | | | | | | | | | |
| corresponding temperature | °C | | N Read pressure with a manometer at the outlet of the generator. | | | | | | | | | | | | |
| | | | N | | | | | | | | | | | | |
| | bar | | O Read pressure with a manometer at the inlet of the generator. | | | | | | | | | | | | |
| | °C | | O | | | | | | | | | | | | |

Others controls

| | | | | | | | | | | | |
|--|---|--|--|---------|---------------------|--|--|--|--|--|---|
| Timer for the GENEGLACE start | Sec | | Z Read the timer value. | | | | | | | | |
| Timer for the reducer stop | Sec | | Z Read the timer value. | | | | | | | | |
| Timer for the pump down | Sec | | Z Read the timer value. | | | | | | | | |
| Refrigerant connection | <table border="1" style="width: 100%; border-collapse: collapse;"> <tr> <td style="width: 25%;">Height</td> <td style="width: 25%;">Length</td> <td style="width: 25%;">Dia / i</td> <td style="width: 25%;">Dia / o</td> </tr> <tr> <td><input style="width: 90%;" type="text"/></td> <td><input style="width: 90%;" type="text"/></td> <td><input style="width: 90%;" type="text"/></td> <td><input style="width: 90%;" type="text"/></td> </tr> </table> | Height | Length | Dia / i | Dia / o | <input style="width: 90%;" type="text"/> | <input style="width: 90%;" type="text"/> | <input style="width: 90%;" type="text"/> | <input style="width: 90%;" type="text"/> | | Height between the generator and the condensing unit. Length of tube between the generator and the condensing unit. Dia : inlet and outlet diameters of connecting tubes. |
| Height | Length | Dia / i | Dia / o | | | | | | | | |
| <input style="width: 90%;" type="text"/> | <input style="width: 90%;" type="text"/> | <input style="width: 90%;" type="text"/> | <input style="width: 90%;" type="text"/> | | | | | | | | |
| Generator located : | <table style="width: 100%;"> <tr> <td style="width: 50%;"></td> <td style="width: 50%; text-align: right;">above the condenser</td> </tr> <tr> <td></td> <td style="text-align: right;">below the condenser</td> </tr> </table> | | above the condenser | | below the condenser | - | Tick the appropriate box. | | | | |
| | above the condenser | | | | | | | | | | |
| | below the condenser | | | | | | | | | | |
| | | - | Tick the appropriate box. | | | | | | | | |
| Oil drainage's frequency | Kg | - | Frequency of oil drainage's | | | | | | | | |
| | | - | | | | | | | | | |

| | | |
|--|--|---|
| Name of the engineer who performed this test : | <input style="width: 90%;" type="text"/> | signature of the person in charge, and stamp of the company : |
| Name of the person in charge : | <input style="width: 90%;" type="text"/> | |
| Date : | <input style="width: 25%;" type="text"/> / <input style="width: 25%;" type="text"/> / <input style="width: 25%;" type="text"/> | |

13.5 Measurement Points for F200 to F2000 NH3 Generator

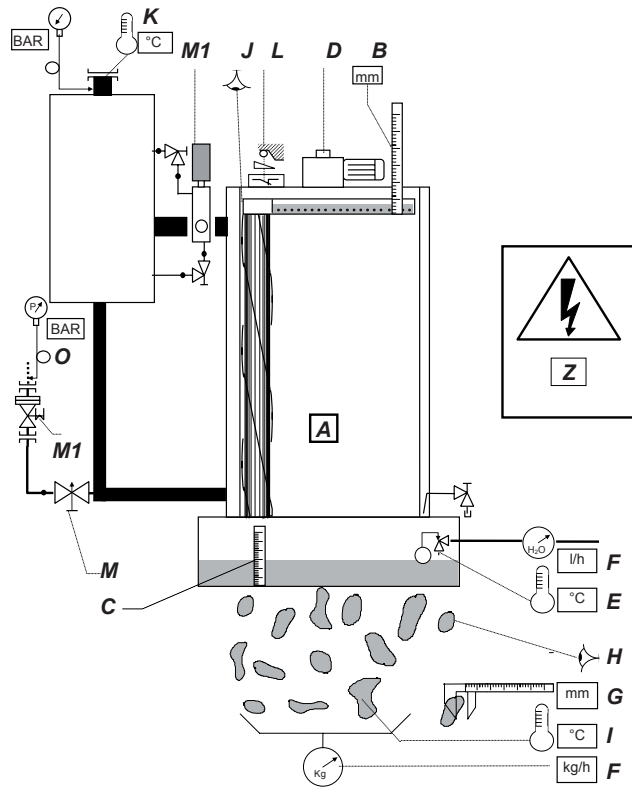

F200 >> F900

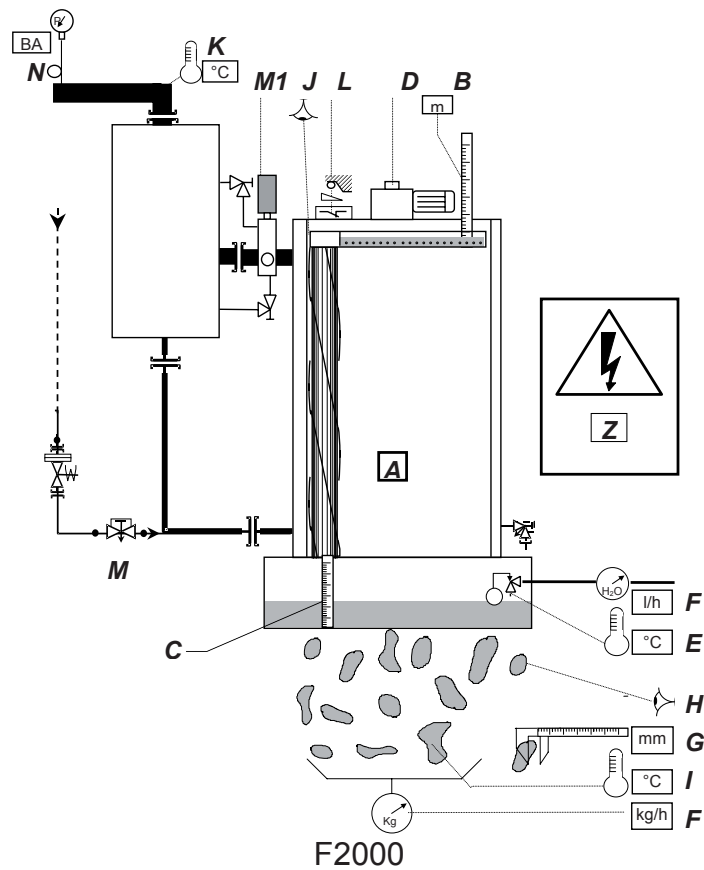

F2000

14. Troubleshooting

The table below will assist you in the diagnosis of any malfunction detected.

| Observations, symptoms and effects | 1 | 2 | 3 | 4 | 5 | 6 | 7 | 8 | 9 | 10 | 11 | 12 | 13 | 14 | 15 | 16 | 17 | 18 | 19 | |
|---|---|---|---|---|---|---|---|---|---|----|----|----|----|----|----|----|----|----|----|--|
| A LOW PRESSURE ABNORMALLY HIGH | | | | | | | | | | | | | | | | | | | | |
| B LOW PRESSURE ABNORMALLY LOW | | | | | | | | | | | | | | | | | | | | |
| C BUBBLES IN THE LIQUID FLOW INDICATOR | | | | | | | | | | | | | | | | | | | | |
| D TORQUE LIMITER CUTS OUT (REAMER LOCKED) | | ▼ | ▼ | | | | | | | | | | | | | | | | | |
| E LP PRESSURE SWITCH CUT OUT | | ▼ | ▼ | | | | | | | | | | | | | | | | | |
| F HP PRESSURE SWITCH CUT OUT | | ▼ | ▼ | | | | | | | | | | | | | | | | | |
| G ROTATING PART MOTOR THERMAL CUT OUT | | ▼ | ▼ | | | | | | | | | | | | | | | | | |
| H CONSTANT DISCHARGE FROM OVERFLOW IN THE BASE | | | | ▼ | | | | | | | | | | | | | | | | |
| I NOISY OPERATION | | ▼ | ▼ | | | | | | | | | | | | | | | | | |
| J UNUSUAL ICING IN SUCTION OF COMPRESSOR | | ▼ | ▼ | | | | | | | | | | | | | | | | | |
| K HARD ICE, DOES NOT EASILY COME AWAY FROM THE CYLINDER, 2 THICKNESSES | | | | | | | | | | | | | | | | | | | | |
| L FINE ICE, TRANSPARENT, MOIST, HAS COME AWAY IN TWO THICKNESSES | | | | | | | | | | | | | | | | | | | | |
| M GRANULAR ICE ON ONE SIDE ("ORANGE PEEL") | | | ▼ | | | | | | | | | | | | | | | | | |
| N IRREGULAR ICE FORMATION, WITH DRIPS | | | | | | | | | | | | | | | | | | | | |
| O ICE ACCUMULATED IN THE BOTTOM OF THE CYLINDER, THICK | | | | | | | | | | | | | | | | | | | | |
| P ICE ACCUMULATING UNDERNEATH THE MACHINE | | | | ▼ | | | | | | | | | | | | | | | | |
| Q ICE DOES NOT COME AWAY EASILY OR NOT AT ALL WHEN THE REAMER OVER | | | | ▼ | | | | | | | | | | | | | | | | |
| R ICE VERY THICK, SOFT, DOES NOT COME AWAY FROM THE CYLINDER | | | | ▼ | | | | | | | | | | | | | | | | |
| S ICE VERY FRAGMENTED | | ▼ | | | | | | | | | | | | | | | | | | |
| T ROTATING PART MOTOR NOT WORKING | | | | | | | | | | | | | | | | | | | | |
| U LOW OIL LEVEL IN COMPRESSOR | | | | | | | | | | | | | | | | | | | | |
| V OIL LEVEL IN COMPRESSOR HIGH WHEN STARTED, THEN LOW | | | | | | | | | | | | | | | | | | | | |
| W DROPE IN ICE PRODUCTION RATE | | | | | | | | | | | | | | | | | | | | |
| Causes | 1 | 2 | 3 | 4 | 5 | 6 | 7 | 8 | 9 | 10 | 11 | 12 | 13 | 14 | 15 | 16 | 17 | 18 | 19 | |
| 1 LACK OF SALT | 1 | | | | | | | | | | | | | | | | | | | |
| 2 TOO MUCH SALT | | 2 | | | | | | | | | | | | | | | | | | |
| 3 FRONT WIPER SETTING LOST OR INCORRECT (LEAK) | | | 3 | | | | | | | | | | | | | | | | | |
| 4 REAR WIPER SETTING LOST OR INCORRECT (LEAK) | | | | 4 | | | | | | | | | | | | | | | | |
| 5 BALL COCK STUCK IN OPEN POSITION OR NOT CLOSING FULLY? HOLE IN FLOAT | | | | | 5 | | | | | | | | | | | | | | | |
| 6 INADEQUATE WATER DISTRIBUTION : HOLES BLOCKED, LOW PUMPING RATE (UNPRIMED) | | | | | | 6 | | | | | | | | | | | | | | |
| 7 NO WATER DISTRIBUTION : WATER CLOSED OFF, BALL COCK STUCK IN CLOSED POSITION, FAULT IN PUMP | | | | | | | 7 | | | | | | | | | | | | | |
| 8 REAMER TOO FAR FROM CYLINDER | | | | | | | | 8 | | | | | | | | | | | | |
| 9 CLEARANCE IN BEARINGS ON SHAFT, INCORRECTLY CENTRED | | | | | | | | | 9 | | | | | | | | | | | |
| 10 SCALE IN CYLINDER | | | | | | | | | | 10 | | | | | | | | | | |
| 11 OIL OR LACK OF REFRIGERANT IN THE DOUBLE WALL : EXCESSIVE SUPERHEAT, LEAK, PARTIAL BLOCKAGE IN FLUID LINE, FILTER OF THERMOSTATIQUE EXPANSION VALVE | | | | | | | | | | | 11 | | | | | | | | | |
| 12 LACK OF REFRIGERATING CAPACITY : CONDENSER DIRTY, HIGH AMBIENT TEMPERATURE, FLAP VALVES ON COMPRESSOR WORN, FILTER OF COMPRESSOR DIRTY | | | | | | | | | | | | 12 | | | | | | | | |
| 13 CONDENSER DIRTY, HIGH AMBIENT TEMPERATURE | | | | | | | | | | | | | 13 | | | | | | | |
| 14 TOO LITTLE A SUPERHEAT OF THE EXPANSIO VALVE | | | | | | | | | | | | | | 14 | | | | | | |
| 15 LACK OF REFRIGERANT, LEAK | | | | | | | | | | | | | | | 15 | | | | | |
| 16 CONDENSATION TOO LOW | | | | | | | | | | | | | | | | 16 | | | | |
| 17 EXCESSIVE REFRIGERATING CAPACITY (EVAPORATION RATE TOO LOW) | | | | | | | | | | | | | | | | | 17 | | | |
| 18 CRANKCASE HEATER OF COMPRESSOR NOT WORKING | | | | | | | | | | | | | | | | | | 18 | | |
| 19 TORQUE LIMITER ELIMINATED OR INCORRECTLY SET | | | | | | | | | | | | | | | | | | | 19 | |

15. Options

The options cover any equipment peripheral to the ice machines connected directly with their operation and offered by GENEGLACE.

15.1 Electrical terminal box

You will find this in the section (diagram of operation) on the terminal box GS-03+N (538 003)

It is suitable for a three phase + neutral supply.

15.2 «ILD» Ice level detector (regulation)

12.2.1 Specifications

| | |
|-----------------------|------------------------------------|
| Supply voltage | 220 volts single phase 50 Hz |
| Consumption | 3 – 4 VA |
| Changeover switch | 1 inverter - 6A - 220V |
| Protection of housing | IP 65 |
| Rotor speed | 12 r.p.m. |
| Reinforced tube | Stainless steel 28 mm diameter |
| Retractable blade | Polyamide |
| Housing | Red ABS |
| Stuffing gland | 16 mm diameter |
| Mounting | Horizontal or vertical |
| Motor | Switched off in detection position |
| Blade | Friction system |

15.2.2 Principle of operation

The unit consists of a motor driving a rod with a probe at the end. The assembly rotates continuously. When the ice reaches the probe, the resistance causes a rotation of the motor on its axis which triggers a small switch.

This switch then cuts the supply to the "ILD" motor and also trips another changeover switch dedicated to the output signal which stops the ice machine. When the level decreases, the "ILD" motor returns to its initial position and starts to rotate again. Production of ice then becomes possible again.

15.2.3 Mounting

It is important to consider the angle of slope formed by the flaked ice in the storage container when choosing the position of the «ILD».

The "ILD" can be installed inside the ice storage container or directly through the wall of the silo using the locking ring provided for the purpose. Every precaution must be taken to ensure that the passage of the "ILD" through the wall is watertight.

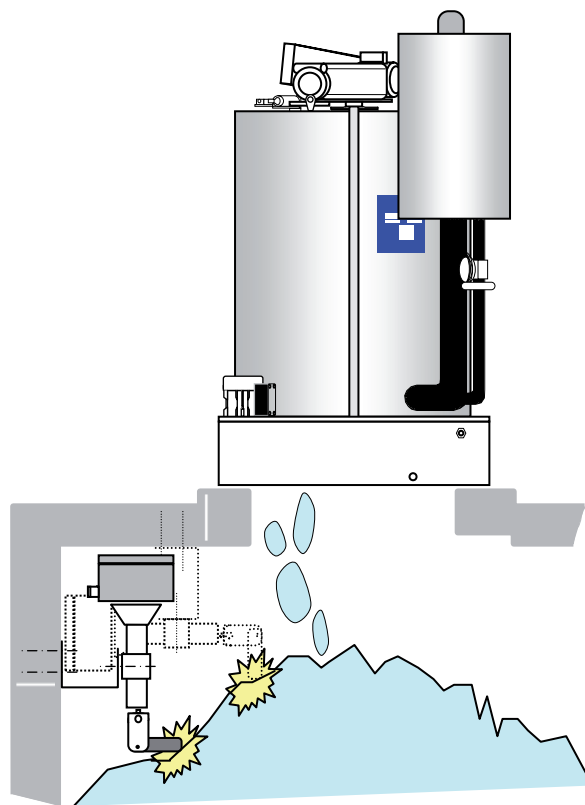

Fig. 8623. Illustration of a possible mounting of the «ILD».

15.2.4 Connection to the terminal box

A 5 core cable is sufficient to connect the «ILD»: 2 for the control (terminals 1 and 2) and three for the power supply (terminals 4, 5 and 6).

Important

In order to avoid repeated starting of the GENEGLACE, it is recommended that you install manual or automatic time-delayed resetting.

15.3 Remote Control

The remote control can be used to set different operating times for the GENEGLACE.

It is a digital time switch controlled by a microprocessor. With this time switch you can enter eight programs to switch the ice machine on and off. Programming instructions and a connection diagram are supplied with the remote control box.

16. Maintenance

16.1 Maintenance schedule

In order to prevent faults or malfunctions, you are advised periodically to examine certain essential points of your GENEGLACE.

The user guide mentions the current service and inspection operations that can be performed. To this must be added :

| Operation | Recommended frequency |
|--|--|
| Examining the gearbox (for traces of oil) | If necessary |
| Examining the internal wall of the drum for scaling Presence of a whitish deposit on the dry wall | If necessary |
| Oil drainage (on NH3 generator) Use drainage valve (Qualified engineers only) | If necessary (Declining Ice production) |
| Recharge standard salt dosing system or Filling up the brine containers for the dosing pump | Depending on consumption |
| Routine inspection Compressor oil level, icing of inlet valve, temperature of casing (Base cools down when stopped), spraying of the wall of the drum, accumulation of ice on the reamer, bearings, regular consumption of salt or salt solution. | Daily |
| Cleaning water system Base, tanks, pump, valve operation | Weekly |
| Cleaning salt dosing device | Monthly |
| Cleaning outside of generator | Monthly |
| Grease bearings (use greasing pump) Central shaft and reamer bearings (Food compatible grease fulfils : NSF.H1 standard), consult us if necessary | Every three months |
| Checking operating pressures | Every three |
| Checking operation of the torque limiter switch and the condition of the wipers | Every three |
| To control the state of refrigerating pipings as well as the insulation (oxidation - attacks chemical ---) to cure it if necessary | Annually |

16.2 Routine maintenance

With time, certain problems can arise with the operation of the ice machine associated with the water quality. The two main sources of problems are scaling and proliferation of micro-organisms.

In addition to the potential risks associated with public health, in both cases the operation of the ice machine can be seriously affected.

We therefore recommend a range of products for descaling and attacking micro-organisms.

Important

These products have been tested on our premises and possess all the reliability criteria in terms of their effectiveness and compatibility with GENEGLACE machines.

The use of other products (for example : hydrochloric acid) will cause irreparable damage to the generator.

For purposes of good hygiene and correct operation, external cleaning of the generator assembly is essential, whenever necessary. Dusting before washing by hand is recommended, in order to prevent bacteria from multiplying. Do not use a water jet, or high pressure washer.

On the front of the water tray base (water inlet side), there is a black plastic plug (3/8 gas), which plugs the base drain hole. This outlet can be used to automate cleaning of the generator. A solenoid valve can be connected to open the drain plug after cleaning and rinsing.

13.2.1 Anti-micro organism product

PR 61 is an anti-algae sanitary decontaminant product for any microbial contamination.

It is in the form of a clear liquid.

- Density 1.02.

- PH 7.

It is sanitary and not dangerous to use.

It is not volatile.

It is rapid and works on any surface.

It has great powers of decontamination.

It can be added to a sanitary descaler to act as both a descaler and decontaminant.

It halts corrosion of the walls of systems attacked by microbial corrosion.

PR 61 consists of dimethyl benzyl ammonium chloride. This type of cationic detergent is authorised in annex 1, an approved product for cleaning equipment that may come into contact with foodstuffs. Decree of 27 October 1975.

16.2.2 Descaling

- Stop the machine or isolate the supply to the terminal box.
- Pour a measure of the descaler into the base tank in accordance with the table.
- Top up with water to reach the overflow of the base.
- Start the reducer and the pump only for about 1 to 2 hours according to scaling.
- Stop operation, drain and rinse 2 or 3 times while restarting the reducer and the pump.

Recommended descaling products

- PR 5200 ST (France)

A technical data sheet accompanies each container, giving instructions for use.

THE INSTRUCTIONS MUST BE READ BEFORE USE.
Average dosage 7%

| Generator | | F200 | F250 | F600 | F800 | F900 | F2000 |
|-----------|-----|------|------|------|------|------|-------|
| Quantity | L | 2,00 | 2,00 | 3,82 | 9,55 | 9,55 | 15,45 |
| | Kg | 2,2 | 2,2 | 4,2 | 10,5 | 10,5 | 17 |
| | lbs | 4,9 | 4,9 | 9,3 | 23,1 | 23,1 | 37,5 |

Important

Take care that the descaler does not fall into the ice storage container.

16.2.3 Oil drain

Oil draining procedure for a generator running on NH3 : by qualified engineers

- To respect the security instructions concerning NH3
- Empty the generator of coolant by closing the liquid inlet valve, and allow the pressure to descend to 0,1 bars.
- Use the pump to circulate warm water (30°C max) for 30 to 60 minutes, in order to liquefy the oil inside the generator. This will make the oil run down quicker to the oil bleed valves at the bottom of the generator.
- Wear a gas mask, and drain the oil, repeat the previous steps, if necessary, until there is no more oil.

16.3 Replacement of worn parts

For dismantling, reassembly and adjustment, the parts are identified in the exploded views in the annex. The average frequencies are given for normal 24h/24 conditions of operation and correct preventive maintenance.

Explanatory sheets for replacement and adjustment are supplied with spare parts or on request. These are coded depending on the generator and its type.

| Part | Frequency | Coding of Data Sheets |
|----------------------------------|---|-----------------------|
| Float valve | When appropriate | 10 |
| Central shaft bearings | About 1095 Days (3 years) | 01 |
| Centring of central shaft | After replacing the bearings | 02 |
| Torque limiter | 1095 Days to 1825 Days (3 to 5 years) | 06 |
| Wipers | 1095 Days to 1825 Days (3 to 5 years) | 03 |
| Water pump | 912 to 1095 Days, Estimated replacement period (2,5 to 3 years) | 20 |
| Reamer and its bearings | 1825 Days to 2555 Days (5 to 7years) | 04/ 05 |
| Reamer bearings | 1095 Days to 1825 Days (3 to 5 years) | 05 |
| Gearbox | 1095 Days, Estimated replacement period (3 years) | 30 |

17. Exploded view

17.1 F200 Generator

This drawing is the property of Généglace, it is forbidden to reproduce it or to communicate it to a third party without our permission

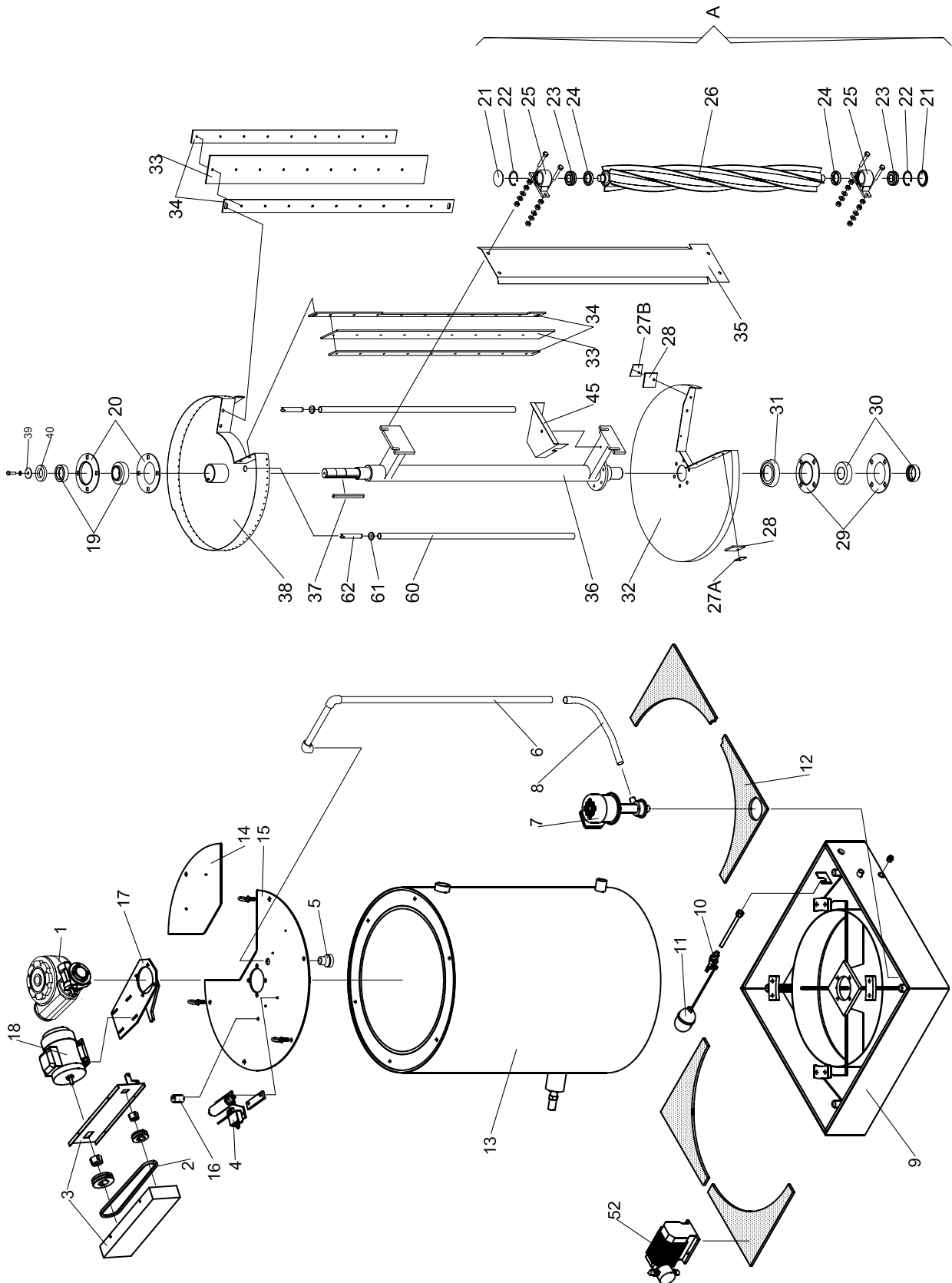

17.2 F250 Generator

This drawing is the property of Généglace, it is forbidden to reproduce it or to communicate it to a third party without our permission

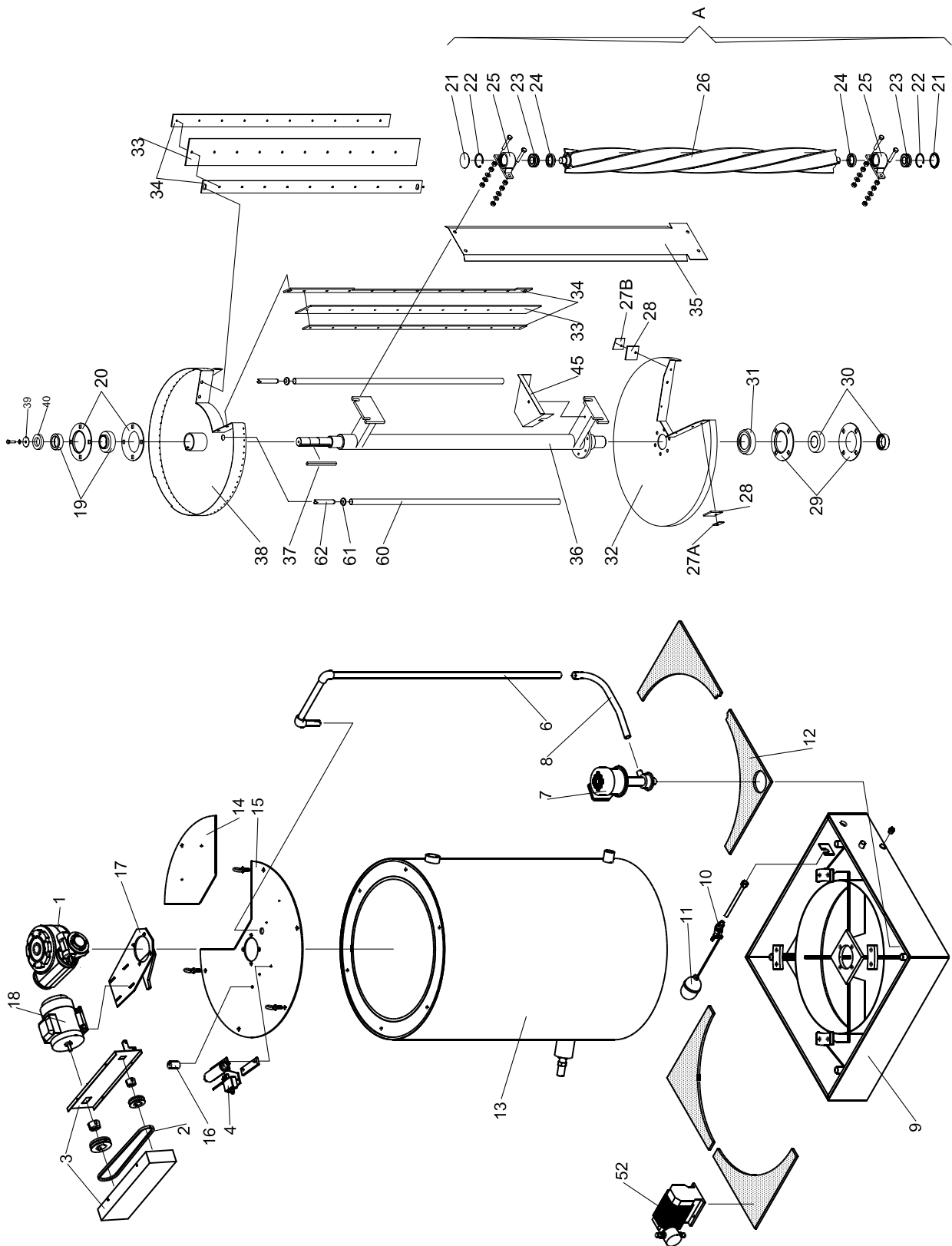

17.3 F600 Generator

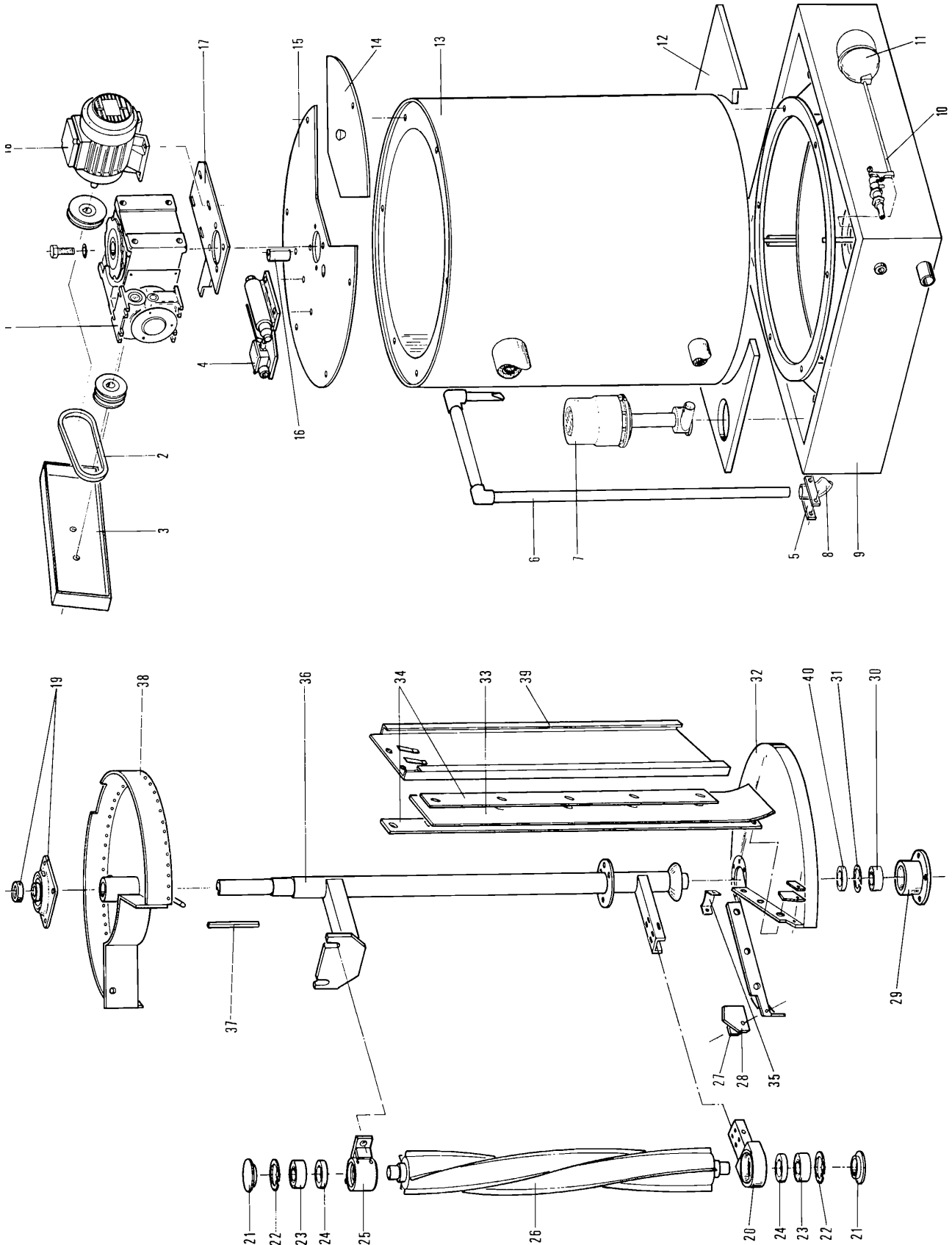

17.4 F800 - F900 - F2000 Generator

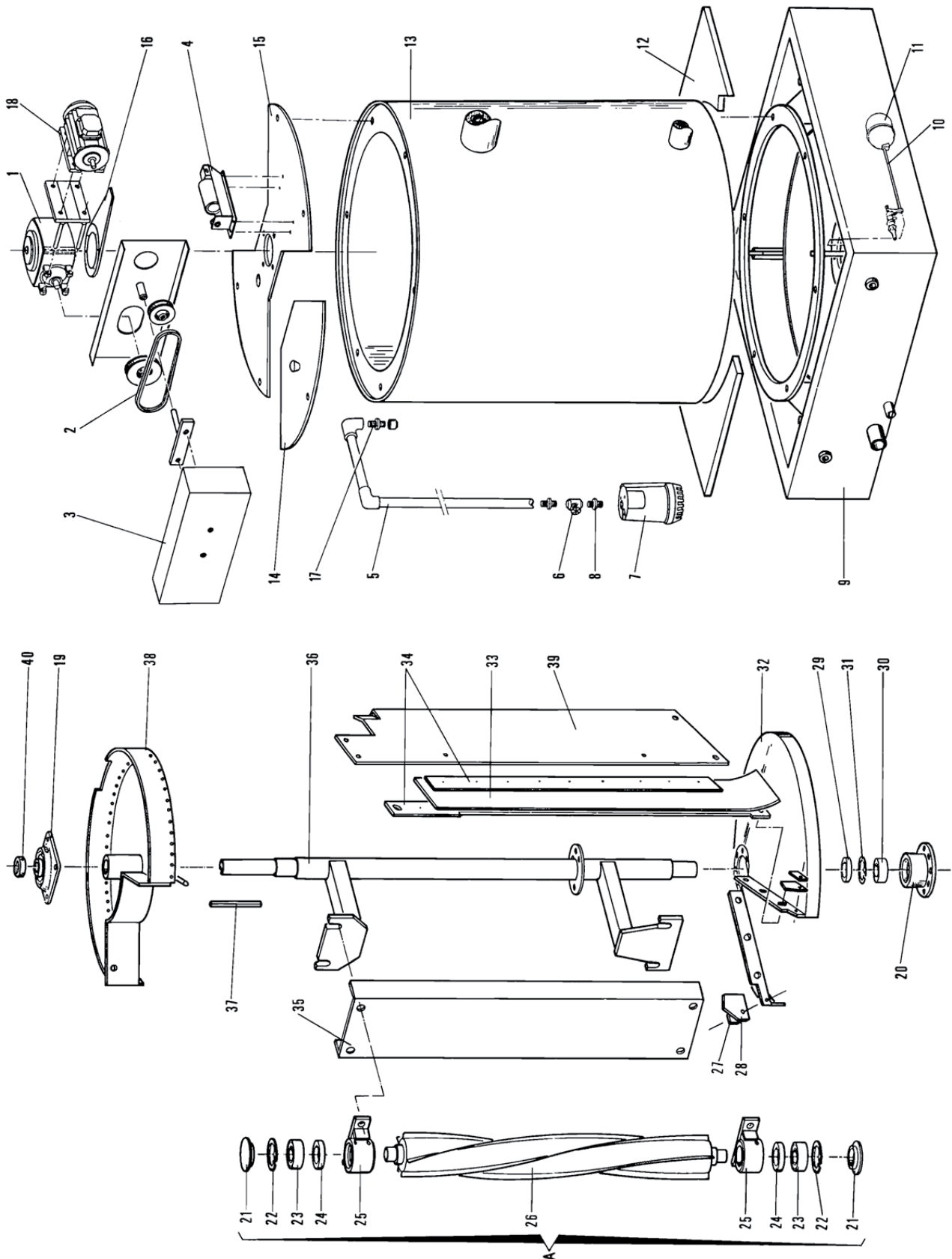

18. Adjustment of Rubber Wipers Blade

Important

Before operating, switch off the installation

- Adjustment of the rubber wipers is by means of oblong fixing holes at the ends of the rubber wiper mountings
- Ensure that the rubber wiper only touches the drum with its outer edge (see Photos below)

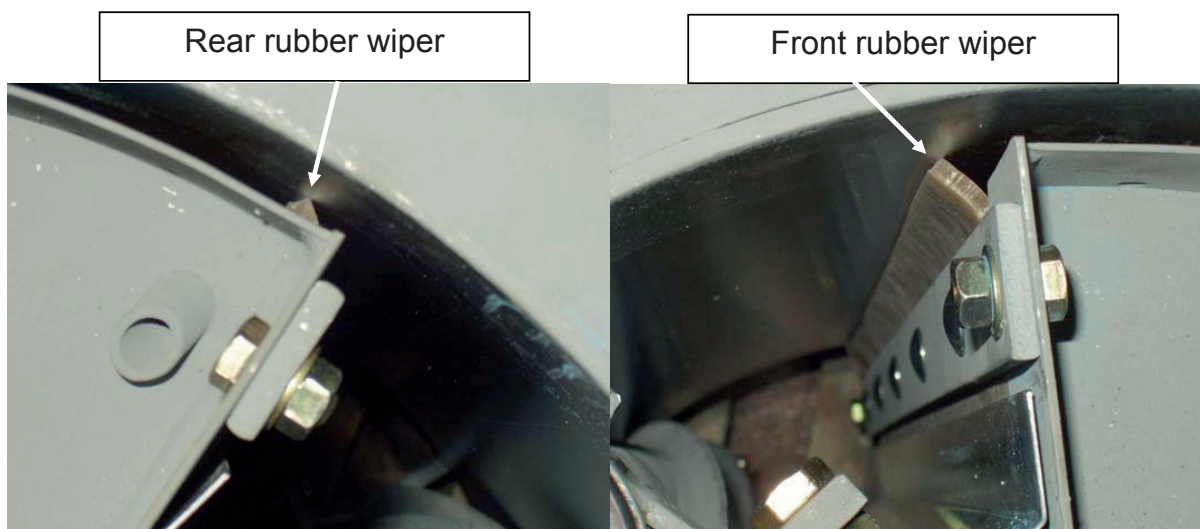
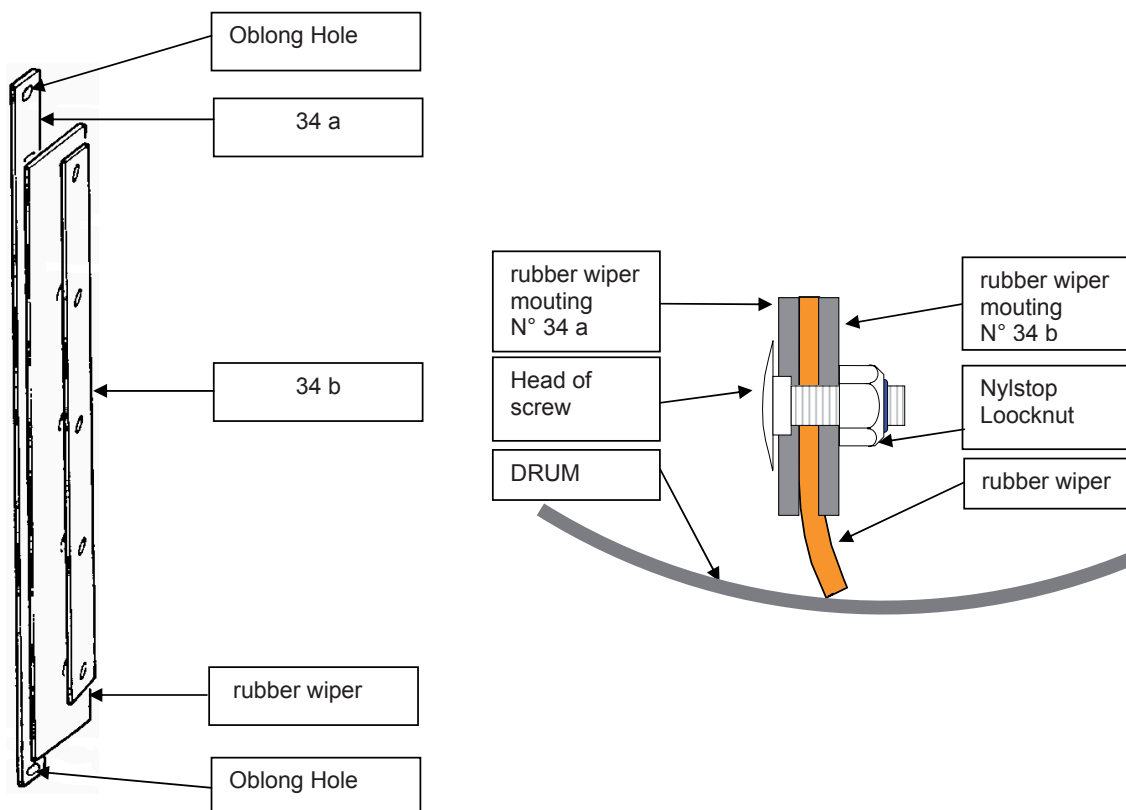

19. Adjusting the Reamer

19.1 F200, F250, F800, F900, F2000

Important

Before operating, switch off the installation

TOOLS REQUIRED :

1 set of engineer's wedges and two 17mm-flat spanners

The adjustment principle referred to below for the top bearing of the reamer is identical to that of the low bearing.

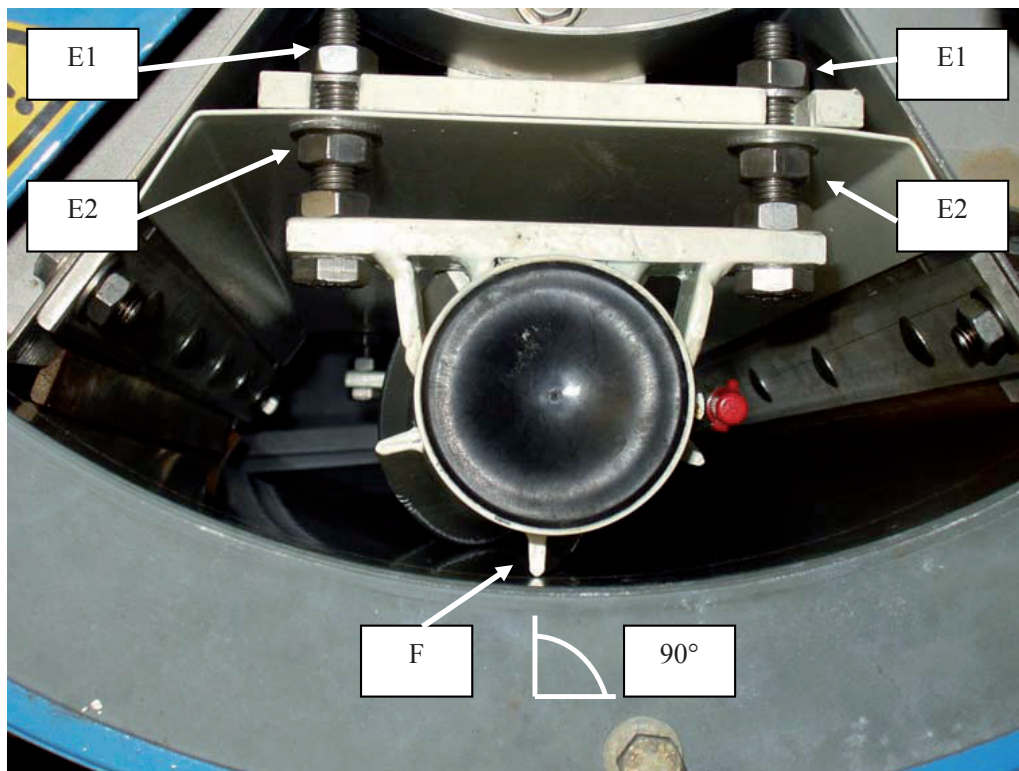

- Place the reamer opposite the inspection hole
- Select the largest tooth on the reamer using a set of engineer's wedges, turning them one after another perpendicular to the cylinder.
- Loosen E1 and E2 screws
- Position the selected tooth (F) perpendicular to the cylinder
- Tighten the E1 screws to distance the reamer tooth from the cylinder

- Unscrew the E2 screws to bring the reamer tooth towards the cylinder
- Take a wedge equal to or less than 0.4mm and place it between the tooth and the cylinder.
- Unscrew the E1 screws and tighten the E2 screws until there is contact between the tooth/wedge/cylinder
- Isolate this adjustment by locking the E1 screws while maintaining the E2 screws
- Remove the wedge by turning the reamer on itself

19.2 F600

Important

Before operating, switch off the installation

TOOLS REQUIRED :

- 1 set of engineer's wedges and two 17mm-flat spanners

Adjusting the upper reamer end

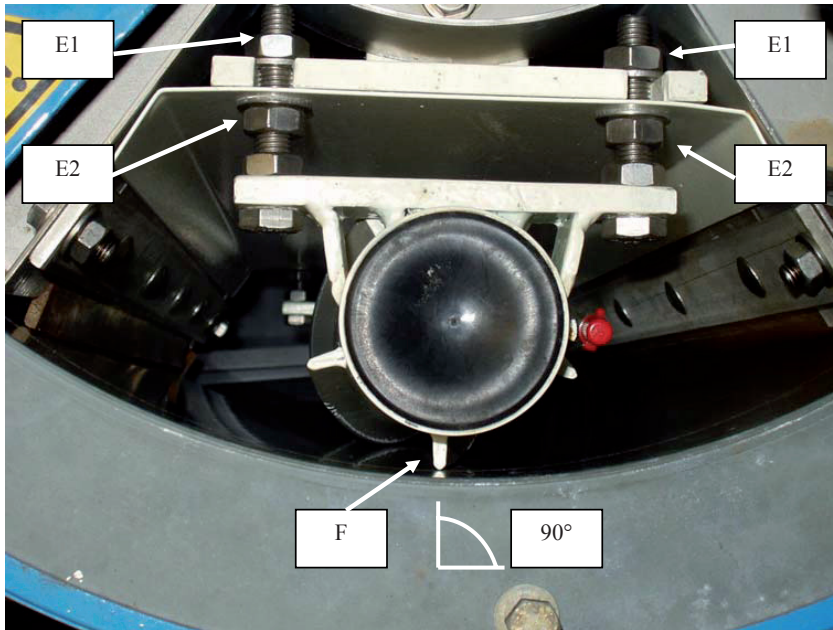

- Place the reamer opposite the inspection hole
- Select the largest tooth on the reamer using a set of engineer's wedges, turning them one after another perpendicular to the cylinder
- Loosen E1 and E2 screws
- Position the selected tooth (F) perpendicular to the cylinder
- Tighten the E1 screws to distance the reamer tooth from the cylinder
- Unscrew the E2 screws to bring the reamer tooth towards the cylinder
- Take a wedge equal to or less than 0.4mm and place it between the tooth and the cylinder.
- Unscrew the E1 screws and tighten the E2 screws until there is contact between the tooth/wedge/cylinder
- Isolate this adjustment by locking the E1 screws while maintaining the E2 screws
- Remove the wedge by turning the reamer on itself

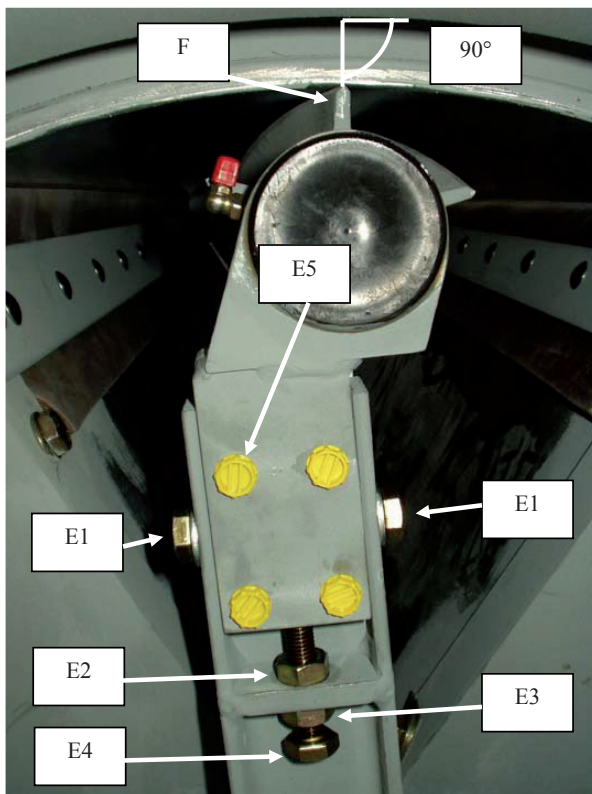

Adjusting lower part

- Place the reamer in an accessible position
- Select the largest tooth on the reamer using a set of engineer's wedges, turning them one after another perpendicular to the cylinder
- Unscrew the E1 screws as well as the four screws which are above the four yellow caps E5
- Position the selected tooth (F) perpendicular to the cylinder
- While holding the E4 screw tight in position, untighten the E2 nut and tighten the E3 nut to move the reamer away from the cylinder
- While holding the E4 screw tight in position, tighten the E2 nut and untighten the E3 nut to bring the reamer tooth close to the cylinder.
- Take a wedge equal to or less than 0.4mm and place it between the tooth and the cylinder.
- While holding the E4 screw tight in position, tighten the E2 nut and untighten the E3 nut until there is contact between the tooth/wedge/cylinder.
- Isolate this adjustment by locking the E3 nut while holding tight the E4 screw. Then lock the E1 screws as well as the four screws above the four yellow caps E5.
- Remove the wedge by turning the reamer on itself

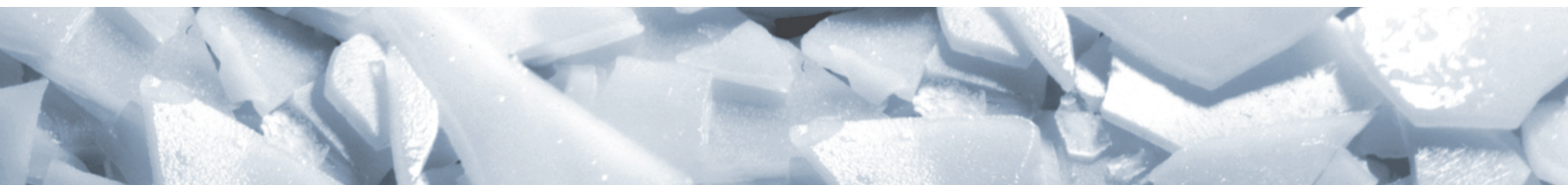

Geneglace SAS

9 rue des Orfèvres

44840 LES SORINIERES

FRANCE

Tel : +33(0)2 51 19 10 51

Fax : +33(0)2 40 05 73 81

Email : contact@geneglace.com

Web : www.geneglace.com