

A	B	C	D	E
553	299	501	9	304

WIRING DIAGRAM C-SC Series 3phase B8

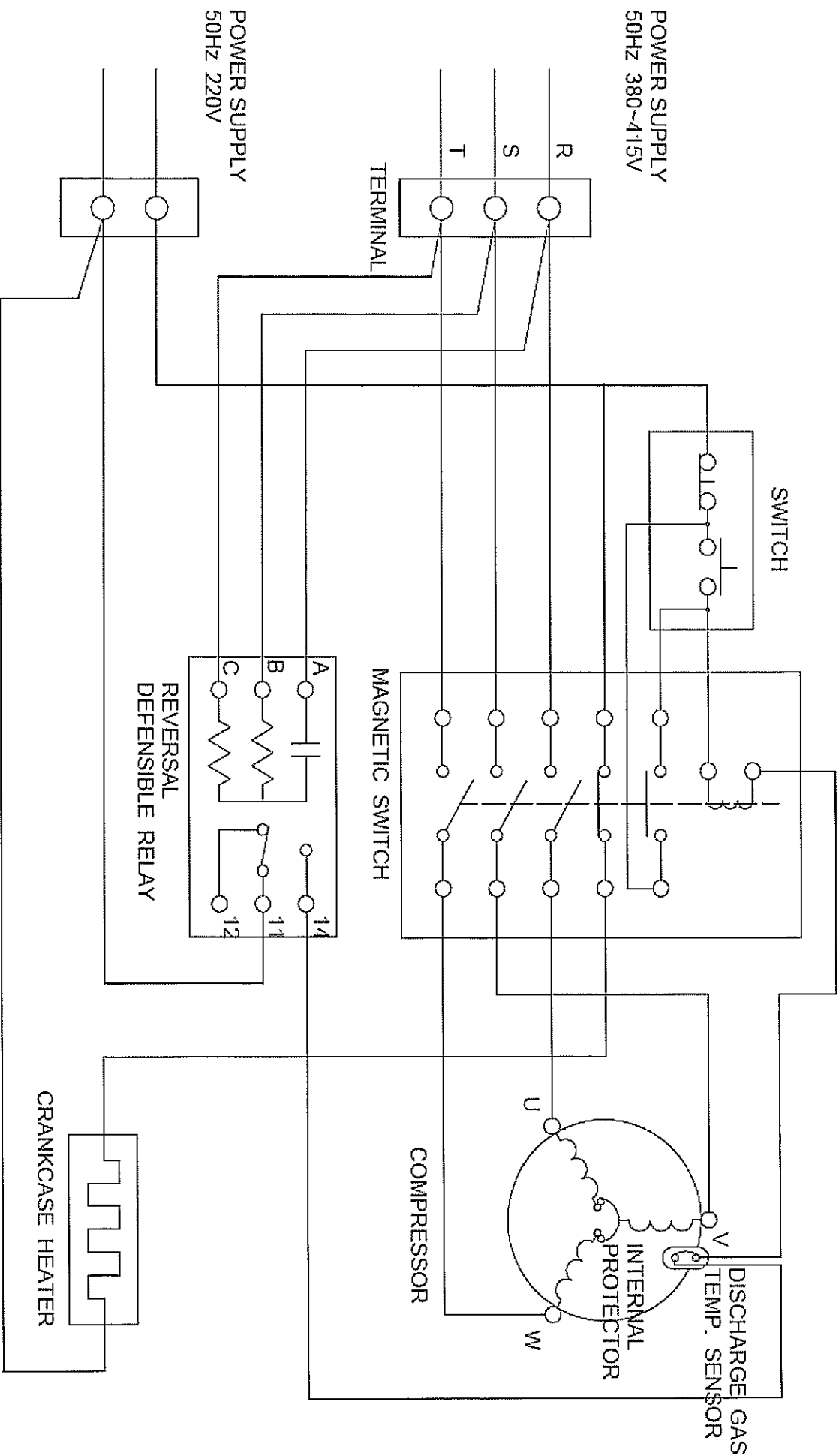

PERFORMANCE DATA

Code No.	C-SCP315H38A
Power Source	3-PH 50Hz 380V
Condensing Temp.(°C)	40.5, 45, 50, 54.4, 60, 65
Suction Gas Superheat(K)	11.1
Sub Cooled(K)	8.3
Compressor Cooling	Natural Cooling
Refrigerant	R410A

Capacity (W)

		Evaporating Temp. (°C)						
		-10	-6.7	0	4.4	7.2	10	12
Condensing Temp. (°C)	40.5	16,878	18,907	23,808	27,699	30,500	33,584	35,976
	45.0	16,144	18,061	22,679	26,338	28,967	31,859	34,100
	50.0	15,364	17,161	21,484	24,899	27,350	30,042	32,125
	54.4	14,707	16,406	20,483	23,697	26,000	28,527	30,481
	60.0		15,494	19,278	22,253	24,381	26,712	28,513
	65.0			18,269	21,045	23,028	25,198	26,872

Input (W)

		Evaporating Temp. (°C)						
		-10	-6.7	0	4.4	7.2	10	12
Condensing Temp. (°C)	40.5	6,656	6,532	6,356	6,295	6,279	6,280	6,292
	45.0	7,170	7,097	6,993	6,956	6,945	6,945	6,951
	50.0	7,796	7,793	7,786	7,783	7,781	7,779	7,778
	54.4	8,395	8,463	8,560	8,592	8,600	8,598	8,590
	60.0		9,395	9,645	9,732	9,755	9,754	9,738
	65.0			10,711	10,854	10,894	10,894	10,869

Current (A)

		Evaporating Temp. (°C)						
		-10	-6.7	0	4.4	7.2	10	12
Condensing Temp. (°C)	40.5	11.91	11.78	11.59	11.52	11.50	11.50	11.52
	45.0	12.70	12.63	12.54	12.51	12.50	12.50	12.50
	50.0	13.64	13.67	13.71	13.72	13.72	13.72	13.72
	54.4	14.52	14.65	14.82	14.88	14.90	14.90	14.88
	60.0		15.99	16.37	16.50	16.53	16.53	16.51
	65.0			17.86	18.06	18.11	18.11	18.08

Coefficients of Polynomial Formula

	Capacity (W)	Input (W)	Current (A)
C1	3.735621E+04	4.167729E+03	7.212811E+00
C2	1.226742E+03	-1.102378E+02	-1.430702E-01
C3	-4.021217E+02	-2.325106E+01	1.555649E-02
C4	2.113153E+01	6.233160E+00	8.099607E-03
C5	-1.005607E+01	2.244689E+00	3.003962E-03
C6	1.681204E+00	1.909445E+00	2.283856E-03
C7	1.265966E-01	-1.311006E-02	-1.197110E-05
C8	-1.728815E-01	-1.240986E-01	-1.677022E-04
C9	3.146374E-07	-1.289246E-06	-1.259029E-09
C10	-3.920115E-06	-1.725538E-06	-1.924604E-09

Note: The polynomial coefficients subject to change without notice.

$$X=C1+C2*(S)+C3*D+C4*(S^2)+C5*(S*D)+C6*(D^2)+C7*(S^3)+C8*(D*S^2)+C9*(S*D^2)+C10*(D^3)$$

X—CAPACITY(W) OR POWER(W) OR CURRENT(A)

S—EVAPORATING TEMP, °C

D—CONDENSING TEMP, °C