

The failure to comply with the dimension stated is bound to imply the risk of malfunctioning of product and/or production

MEASURES COMPLEMENTARY INDICATIONS
The failure to comply with the dimension stated is bound to affect the proper functioning of the product and/or production

Safety limits dimensions

THE PRESENCE OF HARMFUL SUBSTANCES IN THIS COMPONENT IS FORBIDDEN WITHIN THE LIMITS LAID DOWN IN THE PM-01 SPECIFICATION.

The present drawing is property of HUAYI COMPRESSOR BARCELONA S.L and its reproduction and/or transmission without express authorization is forbidden

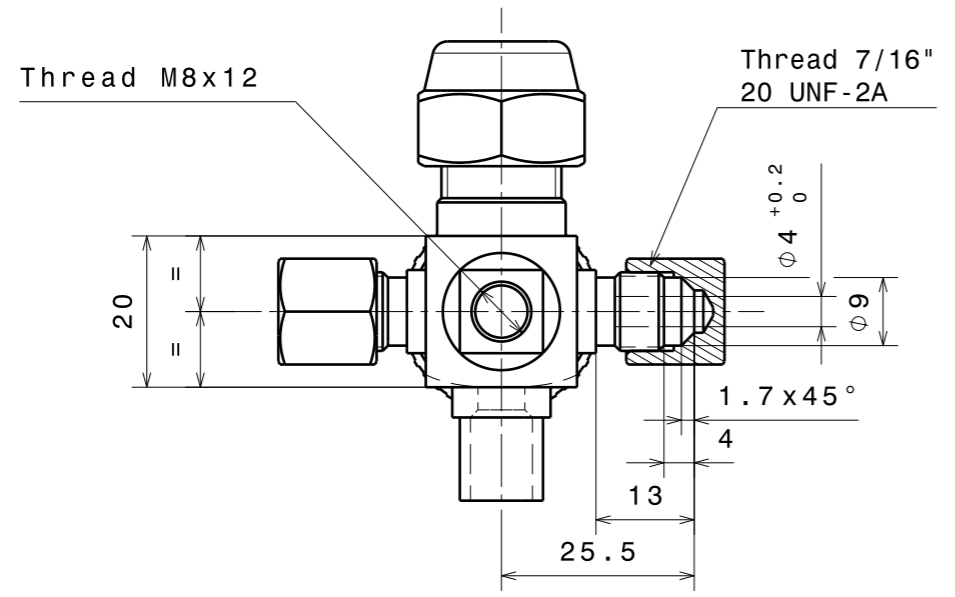

VALVE IDENTIFICATION

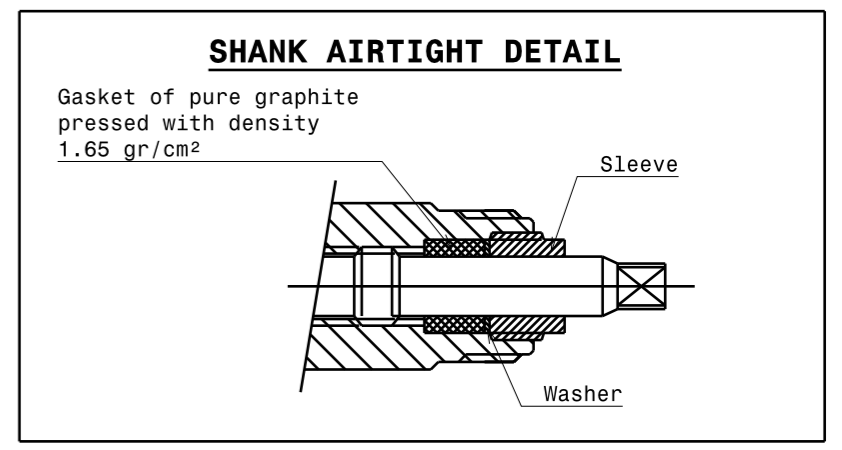
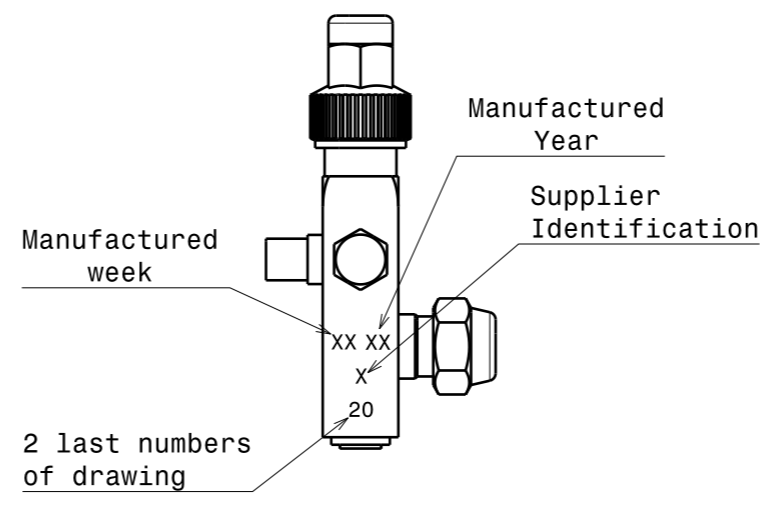

PREFERENTIAL: Iron cap threaded, with exagonal of 21 between faces.
OPTIONAL: Polyester cap threaded with or without charge fiberglass, with exagonal of 20⁰_{-0.33} between faces, color black.

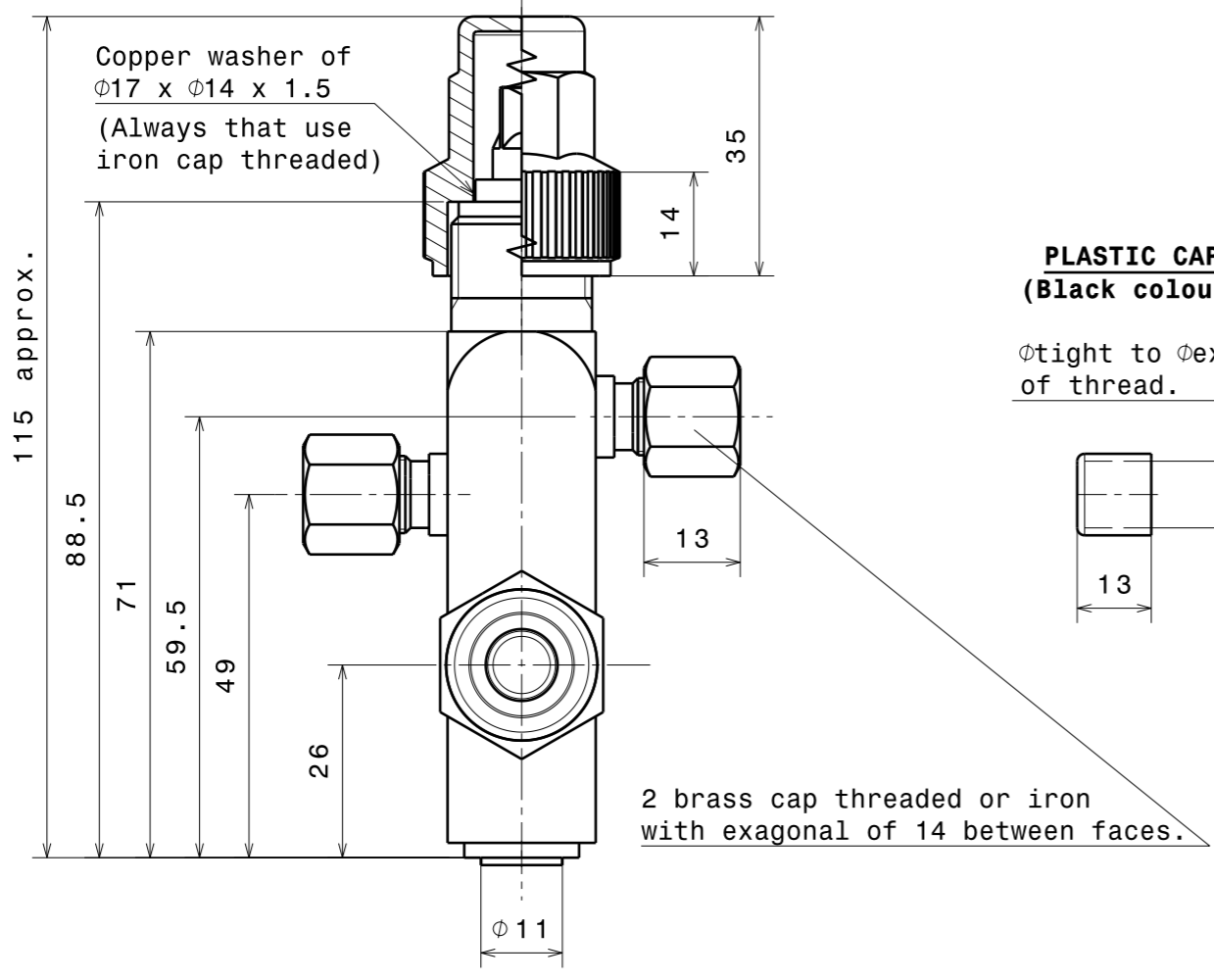

PLASTIC CAP (Black colour)

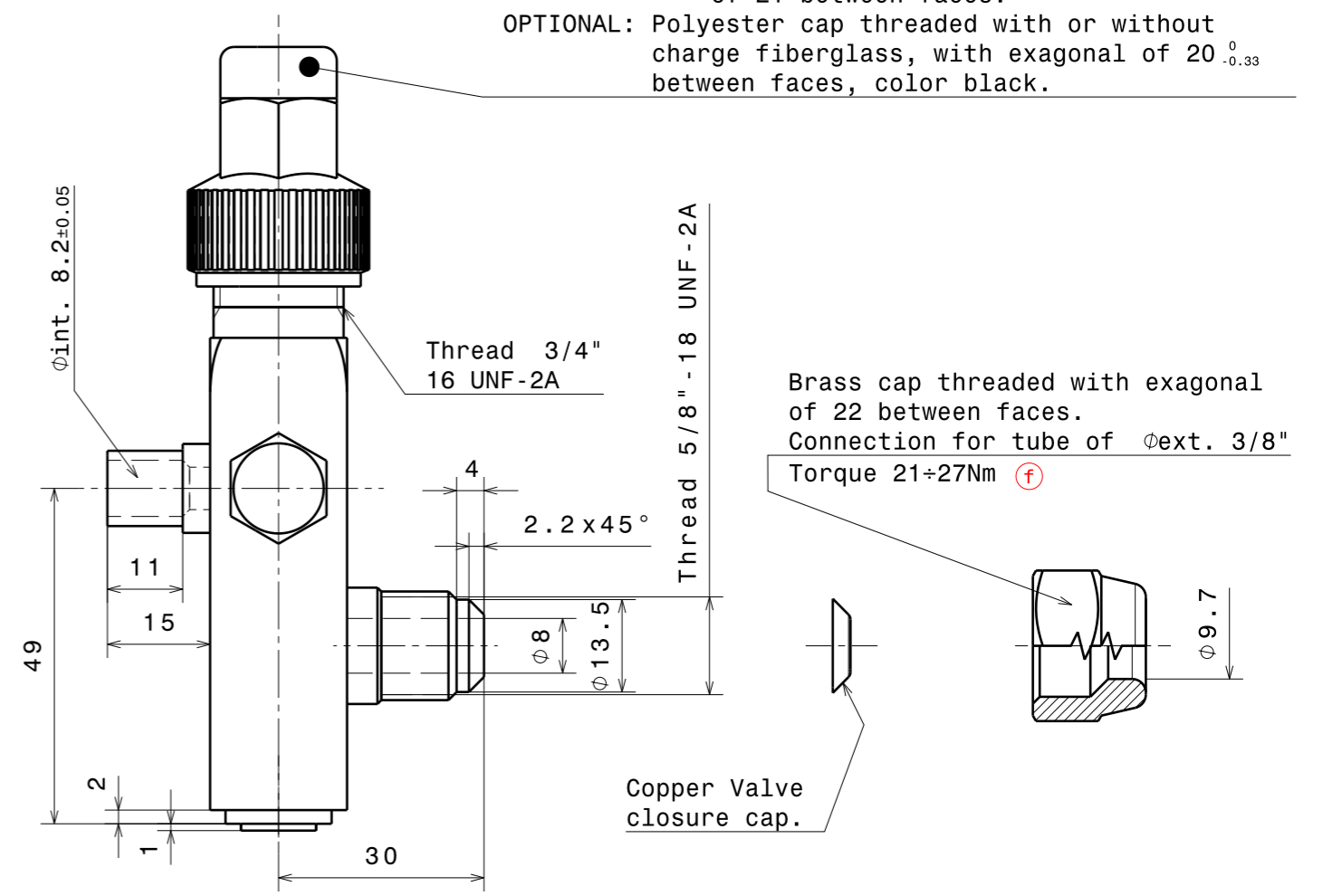
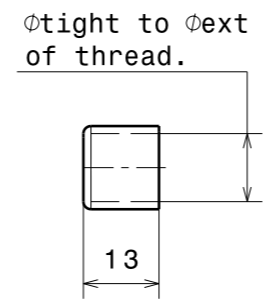

NOTES:

- 1.- The assembly must be clean interior and exterior.
- 2.- The fixed pieces that form the assembly must be welded with copper in reduced atmosphere.
- 3.- Must be received packaged correctly and protected against oxidation.
- 4.- Must be received with the indicated caps.
- 5.- Must not be leaks in both positions (open & closed) when is subject at pression with gas of 20 bar and Torque is of 11 ÷ 22 Nm.
- 6.- The valve must be received in HUAYI with the shank in intermediate position.
- 7.- All iron parts must be zinked or tinning.

MODIFICATIONS		SCALE	GENERAL FINISH SURFACE:	GENERAL TOL.	HUAYI COMPRESSOR BARCELONA R & D	
MOD Date SIGLAS	DESCRIPTION MODIFICATIONS	1:1	(Values in Ra μm)	Lenght: ±0.25 Angle: ±0.5°	DATE	SIGN
d 20.04.10 BSD	Se añade ident. válvula.	MATERIAL/TREATMENT			APPLICATION	
e 05.02.18 AMC	Se actualiza a formato HCB. AM-6506	DRAWN	Mar. 95	XAVI	SUST. A	
f 18.11.19 AMC	Se añade el par de apriete. AM-6902	CHECKED			SUST. POR	
		APPROVED			CODE: 101.679	
		NAME			DRAWING NUMBER	
		SERVICE VALVE 3/8" SAE (for base)			1241020	
					MOD f	