

**CONTROLLERS FOR MULTIPLEXED CABINETS
WITH STEPPER DRIVER INSIDE**

XM678D

-MANUAL FOR THE SW REL. 2.8-

1. GENERAL WARNING 1
 2. BEFORE PROCEEDING 1
 3. GENERAL DESCRIPTION 1
 4. QUICK REFERENCE GUIDE: HOW TO RUN THE SELF ADAPTIVE REGULATION IN 5 STEPS..... 1
 5. INSTALLATION AND MOUNTING 1
 6. WIRING DIAGRAM AND CONNECTIONS 2
 7. BATTERY BACK UP CONNECTION 3
 8. USER INTERFACE 4
 9. HOW TO PROGRAM THE PARAMETERS (PR1 AND PR2)..... 4
 10. FAST ACCESS MENU 4
 11. MENU FOR MULTIMASTER FUNCTION: SEC 5
 12. COMMISSIONING 5
 13. KIND OF REGULATION FOR SUPERHEAT: SELF ADAPTIVE OR MANUAL OPERATING MODE 6
 14. DISPLAY MESSAGES 6
 15. USE OF THE PROGRAMMING HOT-KEY 7
 16. CONTROLLING LOADS 7
 17. TECHNICAL DATA 8
 18. DEFAULT PARAMETER MAP 9

1. GENERAL WARNING

1.1 PLEASE READ BEFORE USING THIS MANUAL

- This manual is part of the product and should be kept near the instrument for easy and quick reference.
- The instrument shall not be used for purposes different from those described hereunder. It cannot be used as a safety device.
- Check the application limits before proceeding.
- Dixell Srl reserves the right to change the composition of its products, even without notice, ensuring the same and unchanged functionality.

1.2 SAFETY PRECAUTIONS

- Check the supply voltage is correct before connecting the instrument.
- Do not expose to water or moisture: use the controller only within the operating limits avoiding sudden temperature changes with high atmospheric humidity to prevent formation of condensation
- Warning: disconnect all electrical connections before any kind of maintenance.
- Fit the probe where it is not accessible by the End User. The instrument must not be opened.
- In case of failure or faulty operation send the instrument back to the distributor or to "Dixell S.r.l." (see address) with a detailed description of the fault.
- Consider the maximum current which can be applied to each relay (see Technical Data).
- Ensure that the wires for probes, loads and the power supply are separated and far enough from each other, without crossing or intertwining.

2. BEFORE PROCEEDING

2.1 CHECK THE SW REL. OF THE XM678D

1. Look at the SW rel. of XM678D printed on the label of the controller.

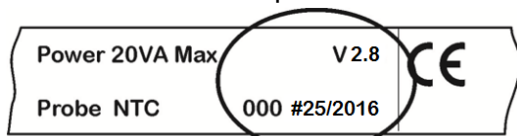

2. If the SW release is 2.8, proceed with this manual otherwise contact Dixell to get the right manual.

3. GENERAL DESCRIPTION

The **XM678D** is a microprocessor based controller for multiplexed cabinets suitable for applications on medium or low temperature. It can be inserted in a proprietary LAN with up to 8 different sections which can operate, depending on the programming, as stand alone controllers or following the commands coming from the other sections. The **XM678D** is provided with 6 relay outputs to control the solenoid valve, defrost - which can be either electrical or hot gas - the evaporator fans, the lights, an auxiliary output and an alarm output and with the **stepper valve driver**. The device is also equipped with six probe inputs: for temperature control, for control the defrost end temperature, for display and the fourth can be used for application with virtual probe or for inlet/outlet air temperature measurement. Moreover, fifth and sixth probe are used to evaluate and control the superheat. Finally, the **XM678D** is equipped with the three digital inputs (free contact) fully configurable by parameters.

The device is equipped with the **HOT-KEY** connector that permits to be programmed in a simple way. The optional direct serial output **RS485** (ModBUS compatible) permits a simple XWEB interfacing. **RTC** is available as options. The **HOT-KEY** connector can be used to connect **X-REP** display (Depending on the model).

4. QUICK REFERENCE GUIDE: HOW TO RUN THE SELF ADAPTIVE REGULATION IN 5 STEPS.

1. After wiring the XM678D, configure the type of valve, bipolar or unipolar, via **tEu** (Default **tEu = bP**: bipolar) and **tEP** (Default **tEP = 0**) parameters or through the manual settings. See par. 6.3 for details.
NOTE: for Alco EX4, EX5, EX6 tEP = 11
For EX3: tEP = 12

2. Set the proper gas via **Fty** parameter, among the following

LABEL	REFRIGERANT	OPERATING RANGE
R22	r22	-50-60°C/-58+120°F
134	r134A	-50-60°C/-58+120°F
290	r290 – Propane	-50-60°C/-58+120°F
404	r404A	-70-60°C/-94+120°F
47A	r407A	-50-60°C/-58+120°F
47C	r407C	-50-60°C/-58+120°F
47F	r407F	-50-60°C/-58+120°F
410	r410A	-50-60°C/-58+120°F
448	r448A	-45-60°C/-69+120°F
449	r449A	-45-60°C/-69+120°F
450	r450A	-45-60°C/-69+120°F
507	r507	-70-60°C/-94+120°F
513	r513A	-45-60°C/-69+120°F
CO2	r744 - Co2	-50-60°C/-58+120°F

Pre-set gas is **R404A**.

3. Configure the probes:

- Regulation and evaporator probe are preset as NTC. If another kind of sensors is used, set it via **P1c** and **P2c** parameters.
- Superheat evaporator outlet probe is pre-set as **Pt1000**, if another kind of sensor is used, set it via **P6c** parameter.
- The **PP11** (-0.5+11bar) is pre-set as **pressure probe**. It operates at relative pressure (**Pru = rE**).
 If you're using a ratiometric transducer, set **P5c = 0-5**, then use parameters **PA4** and **P20** to set the range
NOTE: check the pressure gauge reading with the value of dPP, press the UP arrow once to enter the Fast Access Menu. If ok, proceed; otherwise solve the situation before proceeding acting on par. Pru, PA4 and P20.

4. Set the parameters for self adaptive regulation of superheat

NOTE: the parameters Pb (regulation band) and Int (integral time) are automatically calculated by the controller

- Set **CrE = no**, this disable the continuous regulation of the temperature. Default is **CrE = no**.
- Set **SSH, superheating setpoint**: a value between 4 and 8 is acceptable. Default is **SSH=8**-
- Set **AMS = y** to start the **self adaptive regulation**. Default is **AMS = y**
- Set **ATU = y** to start the search of the **lowest stable superheat**. Default is **ATU = y**. This function reduces automatically the setpoint in order to optimize the use of the evaporator, keeping, at the same time, the superheating regulation stable. The minimum allowed SH set point is **LSH+2°C**.
- Set **LSH, low superheating limit**: a value between 2-4 is acceptable. Default is **LSH = 3**
- Set **SUB, pressure filter**: Default is **Sub = 10**. The value can be increased up to 20 in case of too fast response of the pressure variations.

5. Set the parameters for the temperature regulation

- Set the temperature **setpoint**. Default is **-5°C**
- Set the **differential HY**: Default is **2°C**.
- If the **capacity of the valve** is higher than requested, it can be reduced by the par. **MnF** (Default is 100). A proper setting of **MnF** will reduce the time that the algorithm takes to reach the stability.
MnF value doesn't affect the band width

5. INSTALLATION AND MOUNTING

This device can operate without any user interface, but normal application is with Dixell CX660 keyboard.

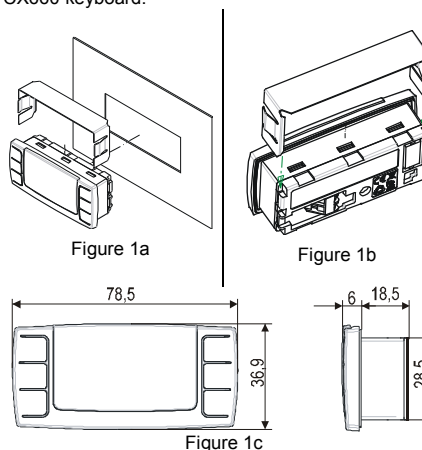

The **CX660** keyboard shall be mounted on vertical panel, in a 29x71 mm hole, and fixed using the special bracket supplied as shown in fig. 1a/1b. The temperature range allowed for correct operation is 0 to 60°C. Avoid places subject to strong vibrations, corrosive gases, excessive dirt or humidity. The same recommendations apply to probes. Let air circulate by the cooling holes.

6. WIRING DIAGRAM AND CONNECTIONS

6.1 IMPORTANT NOTE

XM device is provided with disconnectable terminal block to connect cables with a cross section up to 1.6 mm² for all the low voltage connection: the RS485, the LAN, the probes, the digital inputs and the keyboard. Other inputs, power supply and relay connections are provided with screw terminal block or fast-on connection (5.0 mm). Heat-resistant cables have to be used. Before connecting cables make sure the power supply complies with the instrument's requirements. Separate the probe cables from the power supply cables, from the outputs and the power connections. Do not exceed the maximum current allowed on each relay, in case of heavier loads use a suitable external relay. **N.B. Maximum current allowed for all the loads is 16A.** The probes shall be mounted with the bulb upwards to prevent damages due to casual liquid infiltration. It is recommended to place the thermostat probe away from air streams to correctly measure the average room temperature. Place the defrost termination probe among the evaporator fins in the coldest place, where most ice is formed, far from heaters or from the warmest place during defrost, to prevent premature defrost termination.

6.2 XM678D

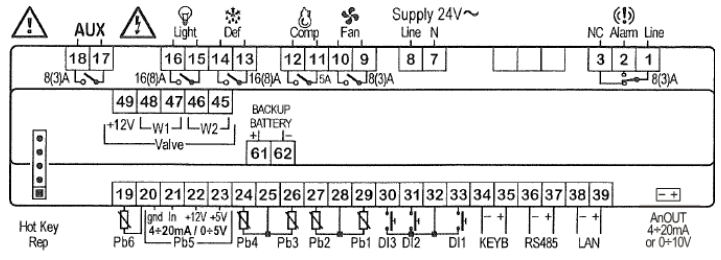

6.3 VALVE CONNECTIONS AND CONFIGURATION

6.3.1 Type of cables and max lenght
To connect the valve to the controller, use only shielded cables with section greater than or equal to 0.823 mm² (AWG18). A twisted shielded cable with the the above specification is suggested. Don't connect the shield to any ground, live it floating.

The max distance between an XM controller and a valve **must not exceed 10 m.**

6.3.2 Valve selection
To avoid possible problems, before connecting the valve configure the driver by making the right changes on the parameters.

- Select the kind of motor (**tEU parameter**)
- Check if the valve is present in **tEP parameter table** reported here below.

→ CHECK THE FOLLOWING TABLE FOR A RIGHT SETTING ←

!!!! In any case, the unique and valid reference has to be considered the datasheet made by valve manufacturer. Dixell cannot be considered responsible in case of valve damaging due to wrong settings!!!!

tEP	Model	LSt (steps*10)	uSt (steps*10)	CPP (mA*10)	CHd (mA*10)	Sr (step/s)	tEu (bip/unip)	HSF (Half/full)
0	Manual settings	Par	Par	Par	Par	Par	Par	Par
1	Danfoss ETS-25/50	7	262	10	10	300	bP	FUL
2	Danfoss ETS-100	10	353	10	10	300	bP	FUL

tEP	Model	LSt (steps*10)	uSt (steps*10)	CPP (mA*10)	CHd (mA*10)	Sr (step/s)	tEu (bip/unip)	HSF (Half/full)
3	Danfoss ETS-250/400	11	381	10	10	300	bP	FUL
4	Sporlan SEI .5 to 11	0	159	12	0	200	bP	FUL
5	Sporlan SER 1.5 to 20	0	159	12	0	200	bP	FUL
6	Sporlan SEI 30	0	319	16	0	200	bP	FUL
7	Sporlan SER(I) G,J,K	0	250	12	0	200	bP	FUL
8	Sporlan SEI-50	0	638	12	0	200	bP	FUL
9	Sporlan SEH(I)-100	0	638	12	0	200	bP	FUL
10	Sporlan SEH(I)-175	0	638	12	0	200	bP	FUL
11	Emerson EX4/EX5/EX6	5	75	50	10	500	bP	FUL
12	Emerson EX3	2	33	0	0	50	uP	HAF

If you can see your valve on the table, please select the valve through **tEP parameter**. In this way, you can be sure of a right configuration. About the connection, please pay attention to the following table to have a quick reference on the connection mode for valves of different manufacturer

4 WIRES VALVES (BIPOLAR)

Connection numbering	ALCO EX4/5/6/7/8	SPORLAN SEI-SEH-SER	DANFOSS ETS
45	BLUE	WHITE	BLACK
46	BROWN	BLACK	WHITE
47	BLACK	RED	RED
48	WHITE	GREEN	GREEN

5-6 WIRES VALVES (UNIPOLAR)

Connection numbering	SPORLAN	SAGINOMIYA
45	ORANGE	ORANGE
46	RED	RED
47	YELLOW	YELLOW
48	BLACK	BLACK
49 - Common	GRAY	GRAY

AFTER MAKING THE CONNECTION, PLEASE SWITCH OFF AND ON THE CONTROLLER IN ORDER TO BE SURE OF THE RIGHT POSITIONING OF THE VALVE.

6.4 WIRING CONNECTION OF EMERSON EX3 VALVE

XM678D AND EX3 CONNECTION

The EX3 valve integrates a solenoid valve with positive shut off on the top and a stepper valve. **Verify the coil voltage of solenoid valve, and connect it to the main line.**

6.4.1 EX3 with 24Vac coil: transformer capacity.

When the coil of the EX3 is at 24Vac and a **UNIQUE** transformer is used to supply both the controller and the coil of the valve, **a 40VA transformer must be used**, like **TF40D**. Any transformer with lower capacity can damage the valve or the controller

6.4.2 Stepper valve connection

The EX3 unipolar valve has to be connected to the following terminals.

XM678D	EX3
Terminal 49	Grey wire
Terminal 48	Blue wire
Terminal 47	Black wire
Terminal 46	Brown wire
Terminal 45	White wire

E.I. Connection of EX3. Verify the voltage of the coil of the shut off valve in the EX3 before connecting

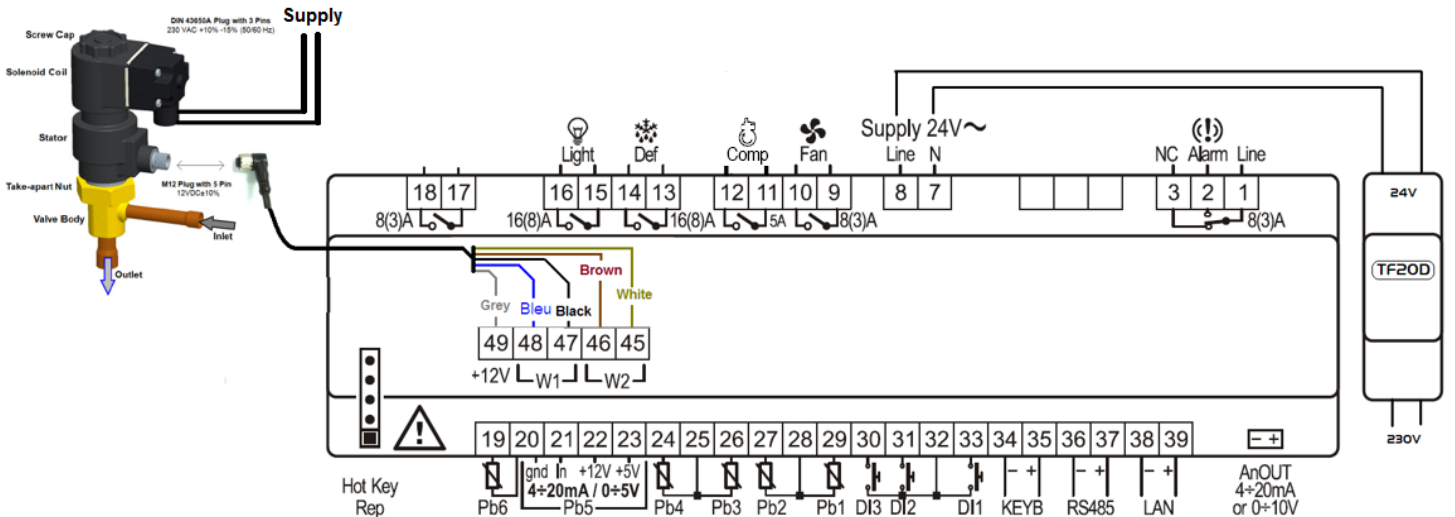

6.5 ABSOLUTE MAXIMUM POWER

XM678D is able to drive a wide range of stepper valves, on the following table are indicated the maximum values of current that the actuator can supply to the stepper wiring. The TF20D Dixell transformer has to be used.

NOTE: the electrical power absorption of the valve can be unrelated to refrigeration power that valve has. Before using the actuator, please read the technical manual of the valve supplied by the manufacturer and check the maximum current used to drive the valve in order to verify that they are lower than those indicated below.

VALVE TYPE	BIPOLAR VALVES (4 wires)	Maximum Current 0.5A
	UNIPOLAR VALVES (5-6 wires)	Maximum Current 0.33A

6.6 KEYBOARD DISPLAY CX660

Polarity:
Terminal [34] [-]
Terminal [35] [+]

Use twisted shielded cable AWG 18 or less in case of long distance.
Max distance: 30m

The XM678D board can operate also without keyboard.

6.7 LAN CONNECTION

Follow next steps to create a LAN connection, which is a necessary condition to perform synchronized defrost (also called master-slave functioning):

- 1) connect a shielded cable between terminals [38] [-] and [39] [+] for a **maximum of 8 sections**;
- 2) the **Adr** parameter is the number to identify each electronic board. **Address duplication is not permitted**, in this case the synchronized defrost and the communication with monitoring system is not guaranteed (the **Adr** is also the ModBUS address). For example, a correct configuration is the following:

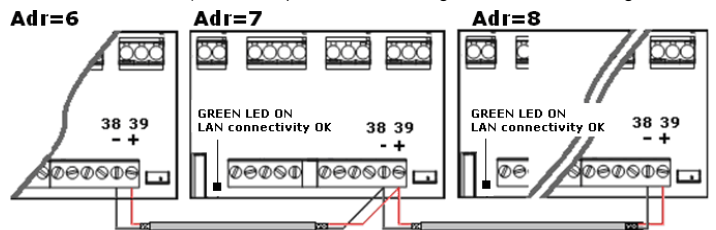

If the LAN is well connected, the green LED will be ON. If the green LED blinks then the connection is wrongly configured.

The max distance allowed is 30m

6.8 SENSORS FOR SUPERHEAT CONTROL

Temperature probe: Pb6 terminals [19] - [20] without any polarity.
Select the kind of sensor with P6C parameter.

Pressure transducer: Pb5 terminals: [21] = input of the signal; [22] = Power Supply for 4to20mA transducer; [20] = GND; [23] = +5Vdc power supply for ratiometric pressure transducer.

Select the configuration of the transducer with parameter P5C.

6.9 HOW TO USE ONLY ONE PRESSURE TRANSDUCER ON MULTIPLEXED APPLICATIONS

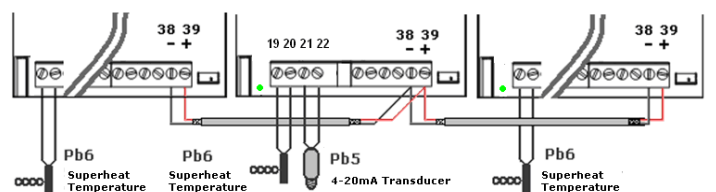

A working LAN connection is required (green LED lit on all XM678D boards of the same LAN). Connect and configure a pressure transducer only on **one** XM678D of the network. Afterwards, the value of pressure read by the unique transducer connected will be available to each device connected to the same LAN.

By pressing **UP ARROW** button, the user will be able to enter a fast selection menu and to read the value of the following parameters:

- dPP = measured pressure (only on master device);
- dP5 = value of temperature obtained from pressure → temperature conversion;
- rPP = pressure value read from remote location (only for slave devices).

Examples of error messages:

dPP = Err → the local transducer read a wrong value, the pressure is out of the bounds of the pressure transducer or the P5C parameter is wrong. Check all these options and eventually change the transducer;

rPF → the remote pressure transducer is on error situation. Check the status of the onboard GREEN LED: if this LED is OFF the LAN is not working, otherwise check the remote transducer.

LAST CHECKS ABOUT SUPERHEAT

On the fast access menu:
dPP is the value read by the pressure gauge;
dP6 is the value read by the temperature probe, temperature of the gas on the outlet section of the evaporator;
SH is the value of the superheat. The nA or Err messages mean that the superheat has no sense in that moment and its value is not available.

6.10 HOW TO CONNECT MONITORING SYSTEM

- 1) Terminals [36] [-] and [37] [+].
- 2) Use shielded twisted cable. For example Belden® 8762 o 8772 or cat 5 cables.
- 3) Maximum distance 1Km.
- 4) Don't connect the shield to the earth or to GND terminals of the device, avoid accidental contacts by using insulating tape.

Only one device for each LAN has to be connected to the RS485 connection.

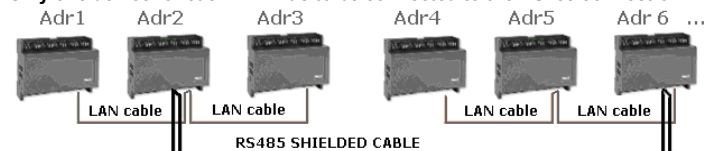

The **Adr** parameter is the number to identify each electronic board. **Address duplication is not permitted**, in this case the synchronized defrost and the communication with monitoring system is not guaranteed (the **Adr** is also the ModBUS address).

6.11 DIGITAL INPUTS

- 1) The terminals from [30] to [33] are all free of voltage;
- 2) Use shielded cable for distance higher than one meter;

For each input, has to be configured: the polarity of activation, the function of the input and the delay of signaling.

The parameters to perform this configuration are i1P, i1F, i1d respectively for polarity, functioning and delay. The i1P can be: cL = active when closed; oP = active when opened. The i1F parameter can be: EAL = external alarm, bAL = serious lock alarm, PAL = pressure switch alarm, dor = door switch, def = external defrost, AUS = auxiliary activation command, LiG = light activation, OnF = board On/OFF, FHU = don't use this configuration. ES = day/night, HdY = don't use this configuration. Then there is i1d parameter for delay of activation. For the others digital inputs there are a set of the same parameters: i2P, i2F, i2d, i3P, i3F, i3d.

6.12 ANALOG OUTPUT

- Selectable between 4 to 20mA and 0 to 10Vdc.
- Use CABJ15 to perform the connections

It's located near the terminal [39] on a 2-pin connector. It's possible to use the output to control anti-sweat heaters through a chopped phase controller XRPW500 (500watt) or family XV...D or XV...K.

7. BATTERY BACK UP CONNECTION

7.1 CONNECTION OF XEC SUPERCAP

XEC Supercap is designed to be used with Dixell products (XM678D, XEV, IEV and others); compatibility with Dixell devices has to be verified in the user manual/technical sheet of the device.

In case of doubt, please contact Dixell Service department.

!!!! IMPORTANT !!!!

XEC Supercap and XM678D **must be powered by two different transformers**; the failure of the observance of this rule may result in damage to the XEC Supercap and / or the connected XM678D.

Wiring connection

XM678D	XEC
Terminal 61 (+)	Terminal 4 (12Vdc)
Terminal 62 (-)	Terminal 3 (gnd)

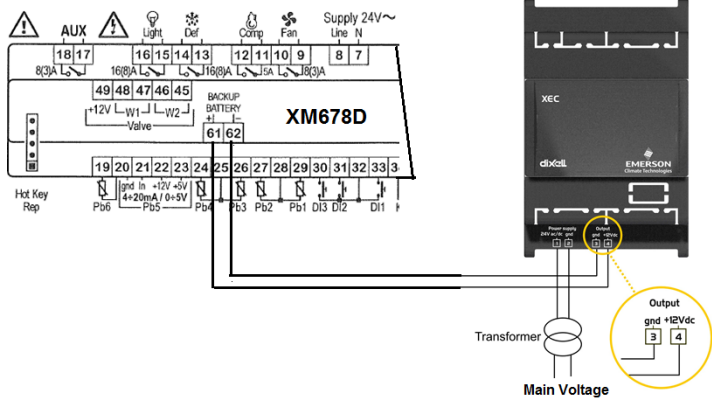

7.2 EMERSON ECP-024 CONNECTION

The Emerson ECP-024 rechargeable accumulator can be connected to the XM678D to close the stepper valve in case of power interruption.

Wiring connection

XM678D	ECP-024
Terminal 61 (+)	Terminal +
Terminal 62 (-)	Terminal -

About conditions of use and limitation please refer to the ECP-024 manuals.

8. USER INTERFACE

8.1 DIRECT COMMAND INTERFACE

UP ARROW
Press and release: Fast access menu
Press and hold 3": SEC Menu
browse parameter, increase the value

DOWN ARROW
Press and release: ON/OFF AUX relay
browse parameter, decrease the value

LIGHT
ON/OFF light relay

SET
Press and release: Show set point

ON/OFF
Press and hold 3": device ON/OFF

8.2 ICONS

Cooling output		
Light →	↓	← Fan
Defrost →	AUX	← Auxiliary relay
Energy saving →	←	Multimaster Enabled
Generic alarm →	←	Clock / time

With icon ON the output is active, while with blinking icon there is a delay.

MEASUREMENT UNIT
°C, Bar and (time) are ON depending on the selection.

DURING PROGRAMMING: blink the measurement units of temperature and pressure

8.3 KEYBOARD COMMANDS

Single commands:

- LIGHT relay** Press light button.
- AUX relay** Press down arrow.
- Manual defrost** Press and hold for 3 sec the defrost button
- ON/OFF** Press for 3 sec the ON/OFF button (if the function is enabled).
- Energy Saving** Press for 3 sec the ON/OFF button (if the function is enabled).

Double commands:

⏏ + ⏏	Press and hold for about 3 sec to lock (Pon) or unlock (PoF) the keyboard.
SET + ⏏	Pressed together to exit from programming mode or from menu; on submenus rtC and EEV this combination allow to come back to previous level.
SET + ⏏	Pressed together for 3 sec allow to access to first level of programming mode.

8.4 HOW TO MODIFY THE SET POINT FOR AIR TEMPERATURE REGULATION

The thermostat set point is the value that will be used to regulate the air temperature. The regulation output is controlled by the electronic valve or by the relay.

BEGIN	SET	Press SET button for 3 sec, the measurement units will blink together.
Value modification	⏏ or ⏏	With the arrows it's possible to change the value within the LS and US parameters value.
EXIT	SET	By pressing SET it is possible to confirm the value that will blink for about 2 sec.

In any case, it is possible to wait for about 10 sec to exit. In order to show the air temperature set is sufficient to press and release the SET button, the value is displayed for about 60 sec.

9. HOW TO PROGRAM THE PARAMETERS (PR1 AND PR2)

The device provide 2 programming levels: **Pr1** with direct access and **Pr2** protected with a password (intended for experts).

ACCESS to Pr1	SET + ⏏	Press and hold for about 3 sec to have access to the first programming level (Pr1).
Select item	⏏ or ⏏	Select the parameter or submenu using the arrows.
Show value	SET	Press SET button.
Modify	⏏ or ⏏	Use the arrows to modify the value.
Confirm and store	SET	Press SET key: the value will blink for 3 sec, and then the display will show the next parameter.
EXIT	SET + ⏏	Instantaneous exit from the programming mode, otherwise wait for about 10 sec (without press any button).

9.1 HOW TO HAVE ACCESS TO "PR2"

To enter Pr2 programming menu:

1. Access to a **Pr1** menu by pressing both **SET+DOWN** keys for 3 sec, the first parameter label will be showed;
2. Press **DOWN** key till the **Pr2** label will be showed, then press **SET**;
3. The blinking **PAS** label will be showed, wait some seconds;
4. Will be showed "0 - ." with blinking 0: insert the password [321] using the keys **UP** and **DOWN** and confirming with **SET** key.

GENERAL STRUCTURE: The first two item **rtC** and **EEV** are related to submenus with others parameters.

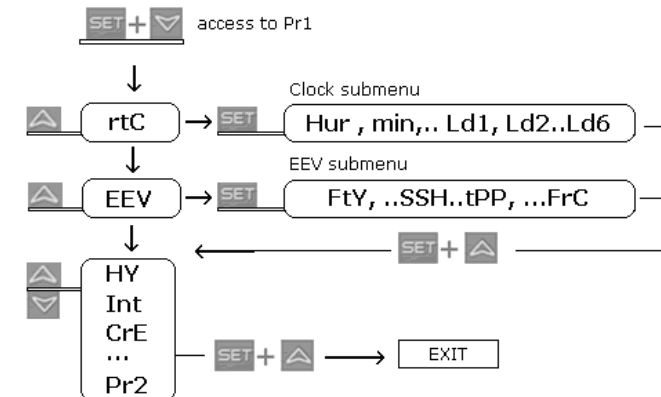

- **SET+UP** keys on **rtC** or **EEV** submenus allow coming back to parameter list,
- **SET+UP** keys on parameter list allow immediate exit.

9.2 HOW TO MOVE PARAMETER FROM PR1 TO PR2 AND VICE VERSA

Enter on **Pr2**; select the parameter; press together **[SET + DOWN]**; a left side LED ON gives to the parameter the presence on **Pr1** level, a left side LED OFF means that the parameter is not present on **Pr1** (only **Pr2**).

10. FAST ACCESS MENU

This menu contains the list of probes and some values that are automatically evacuate by the board such as the superheat and the percentage of valve opening. The values: **nP** or **noP** stands for probe not present or value not evacuate, **Err** value out of range, probe damaged not connected or incorrectly configured.

Entering fast access menu	⏏	By press and release the UP arrow . The duration of the menu in case of inactivity is about 3 min. The values that will be showed depend on the configuration of the board.
----------------------------------	---	--

Use	HM Access to clock menu or reset of the RTC alarm;
	An Value of analog output;
or	SH Value of superheat. nA = not Available;
	oPP Percentage of valve opening.
arrows to select an entry, then press	dp1 (Pb1) Value read by probe 1.
SET	dp2 (Pb2) Value read by probe 2.
to see the value or to go on with other value.	dp3 (Pb3) Value read by probe 3.
	dp4 (Pb4) Value read by probe 4.
	dp5 (Pb5) Temperature read by probe 5 or value obtained from pressure transducer.
	dp6 (Pb6) Value read by probe 6.
	dpP Pressure value read by (Pb5) transducer.
	rPP Virtual pressure probe, only on slave.
	L*t Minimum room temperature;
	H*t Maximum room temperature;
	dPr Virtual probe for room temperature regulation [rPA and rPb];
	dpd Virtual probe for defrost management [dPA];
	dPF Virtual probe for fan management [FPA];
	rSE Real thermoregulation set point: the value includes the sum of SET , HES and/or the dynamic set point if the functions are enabled.
Exit	Pressed together or wait the timeout of about 60 sec

11. MENU FOR MULTIMASTER FUNCTION: SEC

The function "section" **SEC** is enabled when icon is lit. It allows entering in the remote programming mode, from a keyboard not physically connected to the board, through the LAN functionality.

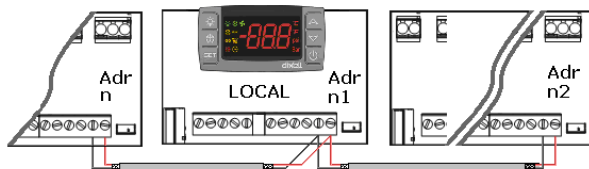

Action	Button or display	Notes
Enter menu		Press UP arrow for about 3 sec, the icon will be ON.
Waiting for action	SEC	The menu to change the section will be entered. SEC label will be displayed.
Enter section list	SET	Press SET to confirm. The following list will be available to select the proper network function.
Select proper function		LOC To gain access only to the local device.
	Or	ALL To gain access to all the devices connected to the LAN.
		SE1 To gain access to the device with 1st Adr (*)
		SEn ... SE8 To gain access to the device with 8th Adr (*)
Confirm	SET	Select and confirm an entry by pressing SET button.
Exit menu		Press SET and UP together or wait about 10 seconds.

(*) The devices on the LAN are indexed by using the **Adr** parameter (in ascending order).

EXAMPLES:

- To modify the same parameter values in all the devices connected to the LAN: enter multimaster menu. Select and confirm **ALL**. Exit from multimaster menu. Enter the programming menu and change the required parameter values. The new values will be changed on all devices connected to the LAN.
- To modify a parameter value in the device with [**Adr = 35**]: find the relevant indexed section (the one linked to [**Adr = 35**]). Enter multimaster menu. Select and confirm this section from the multimaster menu. Exit from multimaster menu. Enter the programming menu and change the required parameter value.
- If the alarm **nod** is present: enter the multimaster menu. Select and confirm the **LOC** section. Exit from multimaster menu.

AT THE END OF THE PROGRAMMING PROCEDURE, SELECT THE SECTION "LOC". IN THIS WAY THE ICON WILL BE SWITCHED OFF!!

11.1 SYNCHRONIZED DEFROST

The synchronized defrost allow to manage multiple defrost from different boards connected through the LAN connection. In this way, the boards can perform simultaneous defrosts with the possibility to end them in a synchronized way.

The **Adr** parameter cannot be duplicated because in this case the defrost cannot be correctly managed.

BEGIN		Press for 3 seconds, the rtC or other will be showed. The measurement unit blinks.
--------------	--	---

Find ADR		Press more than once the DOWN arrow to find the Adr parameter, the press SET .
Modify ADR	or	Set the value of Adr parameter, then press SET to confirm the parameter.
EXIT		Press the two keys together to exit from menu or wait for about 10 seconds.

The **LSn** and **LAN** parameter are only to show the actual settings (read only). Se the following example of configuration:

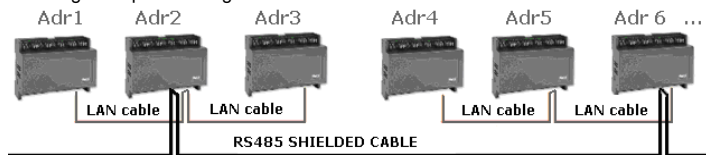

DAILY DEFROST FROM RTC: [EdF = rtC]

ldF Parameter: for safety reason force the value of **ldf** at +1 respect to the interval between two **Ld** parameters. The **ldF** timer is reinitialized after defrost and at every power-on.

DEFROST START: at the time selected by the parameters **Ld1** to **Ld6** or **Sd1** to **Sd6**.
DEFROST END: if the probes reach the **dte** temperature or for maximum **MdF** time.
SAFETY and RtC or RtF ALARM: with clock alarm the device will use the parameter **ldF**, **dte** and **MdF**.

WARNING: don't set [EdF = rtC] and [CPb = n].

MULTIMASTER DEFROST: all the probes with clock

Table for example

Par.	Unit A (RTC)	Unit B (RTC)	Unit C (RTC)
Adr	n	N + 1	N + 2
EdF	rtC (clock)	rtC (clock)	rtC (clock)
ldF	9 hours safety	9 hours safety	9 hours safety
MdF	45 min safety	45 min safety	45 min safety
dte	12°C safety	12°C safety	12°C safety
Ld1	06:00 1°	06:00 1°	06:00 1°
Ld2	14:00 2°	14:00 2°	14:00 2°
Ld3	22:00 3°	22:00 3°	22:00 3°

12. COMMISSIONING

12.1 CLOCK SETTING AND RTC ALARM RESET

If the clock is present: [**EdF = rtC**] enable the defrost from rtc [**Ld1** to **Ld6**].

BEGIN		UP arrow (press once) to access the fast access menu
Display	HM	identify the clock RTC submenu; press SET
Display	HUR = hour → press SET to confirm/modify Min = minutes → press SET to confirm/modify don't use others parameters if present.	
EXIT		Press for about 10 sec. The operation resets the RTC alarm.

Note: the **rtC** clock menu is present also on the second level of parameters.
Warning: if the board shows the **rtF** alarm, the device has to be changed.

12.2 ELECTRONIC VALVE SETTINGS

Some parameters have to be checked:

- Superheat temperature probe:** Ntc, Ptc, Pt1000 with parameter **P6C**. The sensor has to be fixed at the end of the evaporator.
- Pressure transducer:** [4 to 20mA] or ratiometric **P5C = 420** or **5Vr** with parameter **P5C**.
- Range of measurement:** check the parameter of conversion **PA4** and **P20** that are related to the transducer.
TRANSDUCER: [-0.5/7Bar] or [0.5/8Bar abs] the correct setup is relative pressure with **PA4 = -0.5** and **P20 = 7.0**. The [0.5/12Bar abs] the correct setup is relative pressure with **PA4 = -0.5** and **P20 = 11.00**.

Example of virtual pressure with unique [4 to 20mA] or [0 to 5V] transducer:

Param.	XM6x8D_1 without transducer	XM6x8D_2 + with transducer	XM6x8D_3+ without transducer
Adr	n	n + 1	n + 2
LPP	LPP = n	LPP = Y	LPP = n
P5C	LAN or not connect the probe	P5C= 420 or 0-5V	LAN or not connect the probe
PA4	Not used	-0.5 bar	Not used
P20	Not used	7.0 bar	Not used

- From EEV submenu:** select the correct kind of gas with **FTY** parameter.
- Use the following parameters to setup the right valve driving, according to the valve datasheet from the manufacturer.

tEU Type of Stepper motor: [uP-bP] it permits to select the kind of valve. uP = 5 - 6 wires unipolar valves; bP = 4 wires bipolar valves; !!!!! **WARNING !!!!!** by changing this parameter the valve has to be reinitialized.

tEP Predefined valve selection: [0 to 10] if [tEP = 0] the user has to modify all the parameters of configuration in order to use the valve. If **tEP is different from 0** the device performs a fast configuration of the following parameters: **LSt, uSt, Sr, CPP, CHd**. To select the right number please read the following table:

tEP	Model	LSt (steps *10)	uSt (steps *10)	CPP (mA* 10)	CHd (mA* 10)	Sr (step/s)	tEu (bip/unip)	HSF (Half/full)
0	Manual settings	Par	Par	Par	Par	Par	Par	Par
1	Danfoss ETS-25/50	7	262	10	10	300	bP	FUL
2	Danfoss ETS-100	10	353	10	10	300	bP	FUL
3	Danfoss ETS-250/400	11	381	10	10	300	bP	FUL
4	Sporlan SEI .5 to 11	0	159	12	0	200	bP	FUL
5	Sporlan SER 1.5 to 20	0	159	12	0	200	bP	FUL
6	Sporlan SEI 30	0	319	16	0	200	bP	FUL
7	Sporlan SER(I) G,J,K	0	250	12	0	200	bP	FUL
8	Sporlan SEI-50	0	638	12	0	200	bP	FUL
9	Sporlan SEH(I)-100	0	638	12	0	200	bP	FUL
10	Sporlan SEH(I)-175	0	638	12	0	200	bP	FUL
11	Emerson EX4/EX5/EX6	5	75	50	10	500	bP	FUL
12	Emerson EX3	2	33	0	0	50	uP	HAF

If **tEP is different from 0** previous configuration of **LSt, uSt, Sr, CPP and CHd** are overwritten.

HFS Kind of motor movement: (HAF; FUL)

HAF = half step. Use this setting for the unipolar valve.
FUL = half step. Use this setting for the bipolar valve.

LSt Minimum number of steps: [0 to USt] it permits to select the minimum number of steps. At this number of steps the valve should be closed. So it's necessary the reading of manufacturer datasheet to set correctly this parameter. It's the minimum number of steps to stay in advised range of functioning. !!!!! **WARNING !!!!!** By changing this parameter the valve has to be reinitialized. The device performs this procedure automatically and restarts its normal functioning when the programming mode ends.

USt Maximum number of steps: [LSt to 800*10] it permits to select the maximum number of steps. At this number of steps the valve should be completely opened. Read the datasheet provided by manufacturer of the valve to set correctly this parameter. It's the maximum number of steps to stay in advised range of functioning. !!!!! **WARNING !!!!!** By changing this parameter the valve has to be reinitialized. The device performs this procedure automatically and restarts its normal functioning when the programming mode ends.

Est Extra step during closing phase: (0 to 255 (*10)) it sets the number of extra steps the controller performs, when the valve is closed at start up, and during the pauses of regulation, to force the closure of the valve.

NOTE: to set Est the following steps has to be done:

1. Set the kind of valve by the parameter tEP. This pre-set the parameters related to the valve
2. Set the right value of Est

Sr Step rate [10 to 600 step/sec] it's the maximum speed to change step without losing precision (means without losing steps). It's advised to stay under the maximum speed.

CPP Current per phase (only bipolar valves): [0 to 100*10mA] it's the maximum current per phase used to drive valve. It's used only with bipolar valves.

CHd Holding current per phase (only bipolar valves): [0 to 100*10mA] it's the current per phase when the valve is stopped for more than 4 minutes. It's used only with bipolar valves.

13. KIND OF REGULATION FOR SUPERHEAT: SELF ADAPTIVE OR MANUAL OPERATING MODE

13.1 PRESSURE FILTERING – SUB PARAMETER

For a good SH regulation, it's important to use a filtered value of the pressure. This can be done by the parameter Sub.
 Suggested values:

- From 1-5 evaporators for each racks: Sub = 15
- From 6-30 evaporators for each racks: Sub = 10
- More than 30 evaporators for each racks: Sub = 5

13.2 GENERAL CONSIDERATIONS

The controller is able to regulate the superheat in manual or self adaptive mode, according to the value of the parameter AMS, autotuing enabling.

- With **AMS = n**: the normal SH regulation is performed
- With **AMS = y**: the self adaptive SH regulation is performed

13.3 MANUAL OPERATING MODE - AMS = NO

The temperature and SH regulation can be performed in 2 ways according to the value of the parameter CrE: on/off or continuous. See below in details. Standard temperature regulation

13.3.1 ON/OFF TEMPERATURE REGULATION [CrE = n]

1. Temperature regulation is ON/OFF and it depends on the SET point and HY parameter (differential) Valve is closed when the temperature reaches the set point and open when the temperature is higher than set point + differential.
2. The superheat is regulated to be closer to its set point.
3. With more pauses normally also the humidity is bigger.
4. Regulation pauses can be realized using StI and Std parameters (during these pauses the valve is closed).

13.3.2 COUNTINUOUS REGULATION OF THE TEMPERATURE [CrE = Y] (with superheat regulation):

1. The HY parameter becomes temperature band for PI control. A default good value is 6°C.
2. The regulation of injection is continuous and the cooling output is always on. The icon ❄️ is always ON excluding the defrost phase.
3. The superheat is regulated following the SSH parameter.
4. Regulation pauses can be realized using StI and Std parameters (during these pauses the valve is closed).
5. Increasing the Int integral time it is possible to decrease the speed of reaction of the regulator on the HY band.

13.4 SELF ADAPTIVE OPERATING MODE – AMS = YES

Auto-adaptive means to find and maintain the condition of the lowest super heating according to the load and environmental conditions present in a given time on the evaporator.

The parameter AMS enables the self adaptive mode for the superheat regulation. In this functioning the values of Pb and inC parameter are automatically set by the controller according to the kind of applications and the response of the system.

With the **AMS = YES**, CrE must be set at **NO**.

The self adaptive algorithm does not affect, the functions related to the forced opening of the valve in special situation such as:

- **Forced opening of the valve at start of regulation**, parameter SFd (percentage) and Sfd (time).

13.5 MINIMUM STABLE SUPERHEAT SEARCH - AMS = YES, ATU = YES

With the parameter ATU, the minimum stable superheat search function is enabled.

With **ATU = YES** controllers start searching the minimum stable value for the SH, the minimum admitted value in any case is LSH + 2°C (4°F). Please take it in consideration, before setting LSH value.

13.6 VALVE CAPACITY REDUCING – MNF PARAMETER

Thanks to the parameter MnF it's possible to reduce the capacity of the valve, to fine tune the valve to the evaporator.

The regulation band is not affected from the modification of the MnF parameter. See below the behaviour of the capacity of the valve, when the MnF parameter is adjusted.

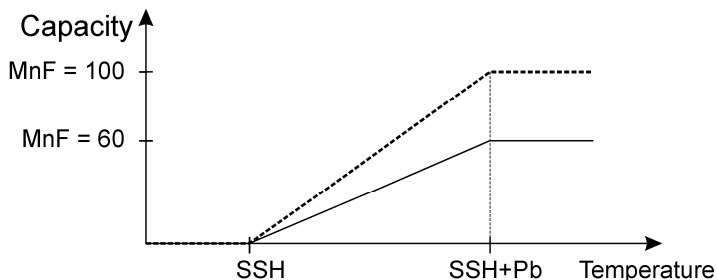

NOTE: during the soft start phase (oPE, SFd), MnF parameter is not taken in consideration and the capacity of the valve is set by the parameters oPE and oPd, respectively.

13.7 AUTO ZERO PROCEDURE (GO HOME FUNCTIONS).

To prevent any possible wrong position caused by a long period of working for the step valve without closing, the controller after gth hours, as soon as the opening open percentage is under 20%, will force a "go home" procedure:

1. Close the valve at max speed, till the complete closure is reached.
2. Perform extra steps (Est)
3. Re-open to the requested regulation position

This procedure is valid for all the valves, and it has to be done at set speed for each valve

14. DISPLAY MESSAGES

	Display	Causes	Notes
		KEYBOARD	
1	nod	No display: the keyboard is trying to work with another board that is not working or not present	Press for 3 sec UP arrow, enter the SEC menu and select LOC entry.
2	Pon	Keyboard is unlocked	
3	PoF	Keyboard is locked	

Display	Causes	Notes
4	rSt Alarm reset	Alarm output deactivated
5	noP, nP nA	Not present (configuration) Not available (evaluation)
6	noL	The keyboard is not able to communicate with the XM668D or XM678D
ALARM FROM PROBE INPUT		
6	P1 P2 P3 P4 P5 P6 PPF CPF	Sensor brake down, value out of range or sensor incorrectly configured P1C, P2C to P6C . PPF can be showed by slaves of pressure that don't receive the value of pressure. CPF is showed when the remote probe 4 is not working.
		P1 : the cooling output works with Con and COF . With defrost probe on error the defrost is performed only at interval. For P5, P6 and PPF : the percentage of the valve opening is fixed at PEO value.
TEMPERATURE ALARM		
7	HA	Temperature alarm from parameter ALU on probe rAL.
8	LA	Temperature alarm from parameter ALL on probe rAL.
9	"HAd"	Defrost high temperature
10	"LAd"	Defrost low temperature
11	"FAd"	Fan low temperature
12	"HAF"	Fan high temperature
DIGITAL INPUT ALARM		
13	dA	Door open alarm from input i1F, i2F or i3F = after delay d1d, d2d or d3d.
14	EA	Generic alarm from digital input i1F, i2F, i3F = EAL.
15	CA	Severe alarm of regulation lock from digital input i1F, i2F, i3F = bAL.
16	PAL	Pressure switch lock i1F, i2F o i3F = PAL.
ELECTRONIC VALVE ALARM		
17	LOP	Minimum operating pressure threshold from LOP parameter.
18	MOP	Maximum operating pressure threshold from MOP parameter.
19	LSH	Low superheating from LSH parameter and SHd delay.
20	HSH	High superheating from HSH parameter and SHd delay.
CLOCK ALARM		
21	rtC	Clock settings lost.
22	rtF	Clock damaged.
OTHERS		
23	EE	EEPROM serious problem.
24	Err	Error with upload/download parameters.
25	End	Parameters have been correctly transferred.

14.1 ALLARM RECOVERY

Probe alarms **P1, P2, P3** and **P4** start some seconds after the fault in the related probe; they automatically stop some seconds after the probe restarts normal operation. Check connections before replacing the probe.
Temperature alarms **HA, LA, HA2** and **LA2** automatically stop as soon as the temperature returns to normal values.
Alarms **EA** and **CA** (with **i1F = bAL**) recover as soon as the digital input is disabled. Alarm **CA** (with **i1F = PAL**) recovers only by **switching off and on** the instrument.

15. USE OF THE PROGRAMMING HOT-KEY

The XM units can UPLOAD or DOWNLOAD the parameter list from its own E2 internal memory to the **HOT-KEY** and vice-versa through a TTL connector. Using **HOT-KEY** the **Adr** will not be changed.

15.1 DOWNLOAD (FROM THE HOT-KEY TO THE INSTRUMENT)

- Turn OFF the instrument by means of the ON/OFF key, insert the **HOT-KEY** and then turn the unit ON.
- Automatically the parameter list of the **HOT-KEY** is downloaded into the controller memory: the **doL** message is blinking. After 10 seconds the instrument will restart working with the new parameters. At the end of the data transfer phase the instrument displays the following messages: **End** for right programming. The instrument starts regularly with the new programming. **Err** for failed programming. In this case turn the unit off and then on if you want to restart the download again or remove the **HOT-KEY** to abort the operation.

15.2 UPLOAD (FROM THE INSTRUMENT TO THE HOT-KEY)

- When the XM unit is ON, insert the **HOT-KEY** and push "**UP**" key

- The **UPLOAD** begins; the **uPL** message is blinking.
- Remove the **HOT-KEY**. At the end of the data transfer phase the instrument displays the following messages:
End = right programming;
Err = failed programming. In this case push **SET** key if you want to restart the programming again or remove the not programmed **HOT-KEY**.

16. CONTROLLING LOADS

16.1 THE COOLING OUTPUT

The regulation is performed according to the temperature measured by the thermostat probe that can be physical probe or virtual probe obtained by a weighted average between two probes following the formula:

$$\text{value_for_room_regulation} = (rPA * rPE + rPb * (100 - rPE)) / 100$$

If the temperature increases and reaches set point plus differential the solenoid valve is opened and then it is closed when the temperature reaches the set point value again. In case of fault in the thermostat probe the opening and closing time of solenoid valve is configured by **Con** and **CoF** parameters.

16.2 STANDARD REGULATION AND CONTINUOUS REGULATION

The temperature regulation can be performed in three ways: the goal of the first way (**standard regulation**) is reaching the best superheat via a classic temperature regulation obtained using hysteresis. The second way permits to use the valve to realize an high performance temperature regulation with a good factor of superheat precision. **This second possibility, it can be used only in centralized plants and it is available only with electronic expansion valve** by selecting [**CrE = Y**] parameter. The third kind of regulation has been thought to be used with vales called evaporator valves [**CrE = EUP**], in this configuration the valve is placed at the end of the evaporator. In any case, the regulation is performed via PI regulator that gives the opening percentage to the valve.

Standard regulation: [CrE = n]

In this case, the **HY** parameter is the differential for standard ON/OFF regulation. In this case the **int** parameter is neglected.

Continuous regulation: [CrE = Y]

In this case, the **HY** parameter is the proportional band of PI in charge of room temperature regulation and we advise to used at least [**HY = 6.0°C/12°F**]. The **int** parameter is the integral time of the same PI regulator. Increasing **int** parameter the PI regulator become slowly in reaction and of course is true vice versa. To disable the integral part of regulation you should set [**int = 0**].

Evaporator valves: [CrE = EUP]

In this case, the system performs a regulation of the temperature without taking in consideration the superheat (in fact the valve is at the end of the evaporator). The **HY** parameter is the proportional band for the temperature regulation and **int** is the integral time for the regulation.

The proportional action is performed only when the compressor relay is on. In this situation there is no superheat regulation.

16.3 DEFROST

Defrost starting

In any case, the device check the temperature read by configured defrost probe before starting defrost procedure, after that:

- (If RTC is present) Two defrost modes are available through the **tdF** parameter: defrost with electrical heater and hot gas defrost. The defrost interval is controlled by parameter **EdF**: (**EdF = rtC**) defrost is made in real time depending on the hours set in the parameters **Ld1** to **Ld6** in workdays and in **Sd1** to **Sd6** on holidays; (**EdF = in**) the defrost is made every **ldF** time.
- Defrost cycle starting can be operated locally (manual activation by means of the keyboard or digital input or end of interval time) or the command can come from the Master defrost unit of the LAN. In this case the controller will operate the defrost cycle following the parameters it has programmed but, at the end of the drip time, will wait that all the other controllers of the LAN finish their defrost cycle before to restart the normal regulation of the temperature according to **dEM** parameter.
- Every time any of the controller of the LAN begin a defrost cycle it issue the command into the network making all the other controllers start their own cycle. This allows a perfect synchronization of the defrost in the whole multiplexed cabinet according to **LMD** parameter.

Defrost ending

- When defrost is started via **rtC**, the maximum duration of defrost is obtained from **Md** parameter and the defrost end temperature is obtained from **dtE** parameter
- If **dPA** is present and [**d2P = Y**], the instrument stops the defrost procedure when **dPA** is higher than **dtE** temperature.

At the end of defrost the drip time is controlled through the **Fdt** parameter.

16.4 FANS

CONTROL WITH RELAY

The fan control mode is selected by means of the **FnC** parameter:
C-n = running with the solenoid valve, OFF during the defrost;
C-Y = running with th1e solenoid valve, ON during the defrost;
O-n = continuous mode, OFF during the defrost;
O-Y = continuous mode, ON during the defrost.

An additional parameter **FSt** provides the setting of temperature, detected by the evaporator probe, above which the fans are always OFF. This can be used to make sure circulation of air only if his temperature is lower than set in **FSt**.

CONTROL WITH ANALOG OUTPUT (if present)

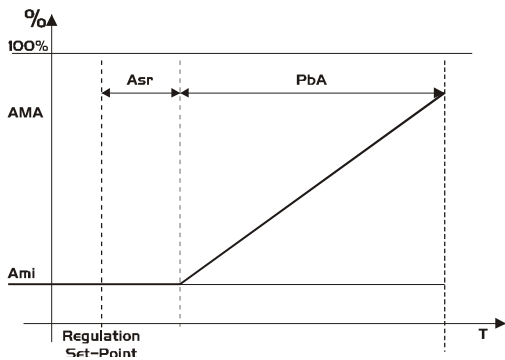

The modulating output [trA = rEG] works in proportional way (excluding the first AMt seconds where the fans speed is the maximum). The regulation set point is relative to regulation set point and is indicated by ASr, the proportional band is always located above [SET + ASr] value and its value is PbA. The fans are at minimum speed AMi when the temperature read by fan probe is [SET + ASr] and the fan is at maximum speed (AMA) when the temperature is [SET + ASr + PbA].

16.5 ANTI SWEAT HEATERS

The anti-sweat heater regulation can be performed with on board relay (if OA6 = AC) or with the analog output (if present by setting trA = AC). However the regulation can be performed in two ways:

- Without real dew-point information: in this case the default value for dew-point is used (SdP parameter).
- Receiving dew-point from XWEB5000 system: the SdP parameter is overwritten when valid value for dew-point is received from XWEB. In case of XWEB link is lost, SdP is the value that will be used for safety.

The best performance can be obtained using probe 4. In this case, the regulation follows the chart:

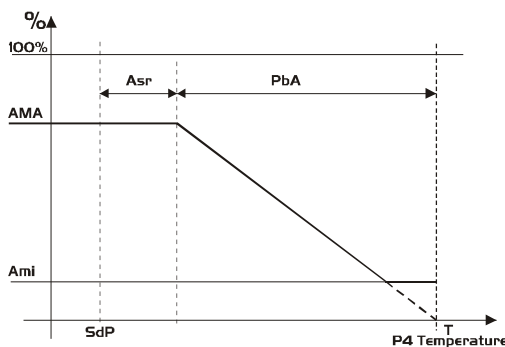

Probe 4 should be placed on the showcase glass. For each cabinet can be used only one probe 4 (P4) sending its value to the others section that are connected to the LAN.

HOW TO WORK WITH PROBE 4 THROUGH THE LAN:

Param.	XM6x8D_1 Without probe 4	XM6x8D_2 + with probe 4	XM6x8D_3+ Without probe 4
Adr	n	n + 1	n + 2
LCP	LCP = n	LCP = Y	LCP = n
P4C	LAN or not connect the probe	P4C = NTC, PtC or PtM	LAN or not connect the probe
trA	trA = AC if the device has the analog output		
OA6	OA6 = AC if the device will use the AUX relay for regulation		

HOW TO WORK WITHOUT PROBE 4:

Param.	XM6x8D Without probe 4
P4C	nP
AMt	% of ON

In this case, the regulation is performed by switching on and off the auxiliary relay on a 60 minutes time base. The ON time will be the AMt value, so that the relay will be ON for AMt minutes and OFF for [60-AMt] minutes.

In case of P4 error or if P4 is absent the output is at AMA value for the AMt time then the output is at 0 value for the time [255 - AMt] time performing a simple PWM modulation.

16.6 AUXILIARY OUTPUT

The auxiliary output is switch ON and OFF by means of the corresponding digital input or by pressing and releasing the down arrow key.

17. TECHNICAL DATA

CX660 keyboard

Housing: self extinguishing ABS

Case: CX660 fascia 35x77 mm; depth 18mm

Mounting: panel mounting in a 29x71 mm panel cut-out

Protection: IP20

Frontal protection: IP65

Power supply: from XM600 power module

Display: 3 digits, red LED, 14.2 mm high

Optional output: buzzer

Power modules

Case: 8 DIN

Connections: Screw terminal block ≤ 1.6 mm² heat-resistant wiring and 5.0mm fast-on or screw terminals.

Power supply: 24Vac

Power absorption: 20VA max.

Inputs: up to 6 NTC; PTC; Pt1000 probes. Max cable length 15m

Digital inputs: 3 free of voltage. Max cable length 15m

Relay outputs: **Total current on loads MAX. 16A.**

Solenoid Valve: relay SPST 5A, 250Vac

Defrost: relay SPST 16A, 250Vac

Fan: relay SPST 8A, 250Vac

Light: relay SPST 16A, 250Vac

Alarm: SPDT relay 8A, 250Vac

Aux: SPST relay 8A, 250Vac

Outputs for valve: bipolar or unipolar valves.

Max distance between controller and valve: up to 10m with shielded twisted cables, AWG 18 (0.823mm²) or less.

Max length for LAN: up to 30m with shielded twisted cables, AWG 20 (0.51mm²) or less.

Optional output (AnOUT) DEPENDING ON THE MODELS:

- PWM / Open Collector outputs: PWM or 12Vdc max 40mA
- Analog output: 4 to 20mA or 0 to 10V

Serial output: RS485 with ModBUS - RTU and LAN

Data storing: on the non-volatile memory (EEPROM)

Kind of action: 1B; Pollution degree: 2

Software class: A

Operating temperature: -10 to 60°C (14 to 140°F)

Storage temperature: -25 to 60°C (-13 to 140°F)

Relative humidity: 20 to 85% (no condensing)

Measuring and regulation range:

NTC probe: -40 to 110°C (-58 to 230°F)

PTC probe: -50 to 150°C (-67 to 302°F)

Pt1000 probe: -100 to 100°C (-148 to 212°F)

Resolution: 0.1°C or 1°C or 1°F (selectable).



























Accuracy (ambient temp. 25°C): ±0.5 °C ±1 digit.





























18. DEFAULT PARAMETER MAP

The numbers of the first column are simple indexes that are unrelated to the position on the device menu. The total amount of parameters can be different depending on the applications. **SUBMENU:** the parameters O1...O24 of the clock belongs to **rtC** label; V1...V30 **ELECTRONIC VALVE** belongs to **EEV**.

	LABEL	VALUE	DESCRIPTION	RANGE	NOTES
	rtC		CLOCK AND DEFROST By pressing SET it's possible to enter on RTC submenu		Access to CLOCK submenu (if present)
	CbP	---	RTC presence	---	Y = the optional RTC board is used. N = the optional RTC board is not used even if mounted
	Hur	---	Hours.	---	-
	Min	---	Minutes.	---	-
	dAY	---	Day of the week.	Sun(0); SA(6)	-
	Hd1	nU	First weekly day.	Sun(0); SA(6); nu(7)	Set the first day of the week which follows the holiday times.
	Hd2	nU	Second weekly day.	Sun(0); SA(6); nu(7)	Set the second day of the week which follows the holiday times.
	Hd3	nU	Third weekly day.	Sun(0); SA(6); nu(7)	Set the third day of the week which follows the holiday times.
	iLE	0.0	Energy saving cycle start during workdays.	0.0 to 23h50min (143)	During the Energy Saving cycle the set point is increased by the value in HES so that the operation set point is [SET + HES] . Format: hours.10min, resolution: 10min.
	dLE	0.0	Energy saving cycle length during workdays.	0.0 to 24h00min (144)	Set the duration of the Energy Saving cycle on workdays. Format: hours.10min, resolution: 10min.
	iSE	0.0	Energy saving cycle start during holidays.	0.0 to 23h50min (143)	Format: hours.10min, resolution: 10min.
	dSE	0.0	Energy saving cycle length during holidays.	0.0 to 24h00min (144)	Format: hours.10min, resolution: 10min.
	HES	0.0	Temperature increasing during Energy Saving cycle (Day/Night).	[-30.0°C to 30.0°C] [-54°F to 54°F]	Set the increasing value of the set-point during the Energy Saving cycle.
	Ld1	6.0	Workdays First defrost start.	0.0 to 23h50min (143) nU(144)	Workdays defrost start: [Ldn to 23h50min] these parameters set the beginning of the eight programmable defrost cycles during workdays. Ex: when [Ld2 = 12.4] the second defrost starts at 12.40 during workdays. nU = not used. Format: hours.10min, resolution: 10min.
	Ld2	13.0	Workdays Second defrost start.	Ld1 to 23h50min (143) nU(144)	
	Ld3	21.0	Workdays Third defrost start.	Ld2 to 23h50min (143) nU(144)	
	Ld4	nU	Workdays Fourth defrost start.	Ld3 to 23h50min (143) nU(144)	
	Ld5	nU	Workdays Fifth defrost start.	Ld4 to 23h50min (143) nU(144)	
	Ld6	nU	Workdays Sixth defrost start.	Ld5 to 23h50min (143) nU(144)	
	Sd1	6.0	Holidays First defrost start.	0.0 to 23h50min (143) nU(144)	Holidays defrost start: [Sdn to 23h50min] these parameters set the beginning of the eight programmable defrost cycles on holidays. Ex: when [Sd2 = 3.4] the second defrost starts at 3.40 on holidays. nU = not used. Format: hours.10min, resolution: 10min.
	Sd2	13.0	Holidays Second defrost start.	Sd1 to 23h50min (143) nU(144)	
	Sd3	21.0	Holidays Third defrost start.	Sd2 to 23h50min (143) nU(144)	
	Sd4	nU	Holidays Fourth defrost start.	Sd3 to 23h50min (143) nU(144)	
	Sd5	nU	Holidays Fifth defrost start.	Sd4 to 23h50min (143) nU(144)	
	Sd6	nU	Holidays Sixth defrost start.	Sd5 to 23h50min (143) nU(144)	
	Lo1	nU	Workdays First light switch.	0.0 to 23h50min (143) nU(144)	Format: hours.10min, resolution: 10min.
	Lo2	nU	Workdays Second light switch.	Lo1 to 23h50min (143) nU(144)	
	Lo3	nU	Workdays Third light switch.	Lo2 to 23h50min (143) nU(144)	
	Lo4	nU	Workdays Fourth light switch.	Lo3 to 23h50min (143) nU(144)	
	Lo5	nU	Workdays Fifth light switch.	Lo4 to 23h50min (143) nU(144)	
	Lo6	nU	Workdays Sixth light switch.	Lo5 to 23h50min (143) nU(144)	
	dLo	0.0	Light on time during workdays.	0.0 to 24h00min (144)	Set the duration of the light on time on workdays. Format: hours.10min, resolution: 10min.
	So1	nU	Holidays First light switch.	0.0 to 23h50min (143) nU(144)	Format: hours.10min, resolution: 10min.
	So2	nU	Holidays Second light switch.	So1 to 23h50min (143) nU(144)	
	So3	nU	Holidays Third light switch.	So2 to 23h50min (143) nU(144)	
	So4	nU	Holidays Fourth light switch.	So3 to 23h50min (143) nU(144)	
	So5	nU	Holidays Fifth light switch.	So4 to 23h50min (143) nU(144)	
	So6	nU	Holidays Sixth light switch.	So5 to 23h50min (143) nU(144)	
	dSo	0.0	Holidays Sixth defrost start.	0.0 to 24h00min (144)	Set the duration of the light on time on holidays. Format: hours.10min, resolution: 10min.
	EEU		ELECTRONIC VALVE		By pressing SET you can enter electronic expansion valve submenu.

	LABEL	VALUE	DESCRIPTION	RANGE	NOTES																																													
				Type of gas used by plant. Fundamental parameter for correct functioning of all system.																																														
				<table border="1"> <thead> <tr> <th>LABEL</th> <th>REFRIGERANT</th> <th>OPERATING RANGE</th> </tr> </thead> <tbody> <tr><td>R22</td><td>r22</td><td>-50-60°C/-58+120°F</td></tr> <tr><td>134</td><td>r134A</td><td>-50-60°C/-58+120°F</td></tr> <tr><td>290</td><td>r290 – Propane</td><td>-50-60°C/-58+120°F</td></tr> <tr><td>404</td><td>r404A</td><td>-70-60°C/-94+120°F</td></tr> <tr><td>47A</td><td>r407A</td><td>-50-60°C/-58+120°F</td></tr> <tr><td>47C</td><td>r407C</td><td>-50-60°C/-58+120°F</td></tr> <tr><td>47F</td><td>r407F</td><td>-50-60°C/-58+120°F</td></tr> <tr><td>410</td><td>r410A</td><td>-50-60°C/-58+120°F</td></tr> <tr><td>448</td><td>r448A</td><td>-45-60°C/-69+120°F</td></tr> <tr><td>449</td><td>r449A</td><td>-45-60°C/-69+120°F</td></tr> <tr><td>450</td><td>r450A</td><td>-45-60°C/-69+120°F</td></tr> <tr><td>507</td><td>r507</td><td>-70-60°C/-94+120°F</td></tr> <tr><td>513</td><td>r513A</td><td>-45-60°C/-69+120°F</td></tr> <tr><td>CO2</td><td>r744 - Co2</td><td>-50-60°C/-58+120°F</td></tr> </tbody> </table>	LABEL	REFRIGERANT	OPERATING RANGE	R22	r22	-50-60°C/-58+120°F	134	r134A	-50-60°C/-58+120°F	290	r290 – Propane	-50-60°C/-58+120°F	404	r404A	-70-60°C/-94+120°F	47A	r407A	-50-60°C/-58+120°F	47C	r407C	-50-60°C/-58+120°F	47F	r407F	-50-60°C/-58+120°F	410	r410A	-50-60°C/-58+120°F	448	r448A	-45-60°C/-69+120°F	449	r449A	-45-60°C/-69+120°F	450	r450A	-45-60°C/-69+120°F	507	r507	-70-60°C/-94+120°F	513	r513A	-45-60°C/-69+120°F	CO2	r744 - Co2	-50-60°C/-58+120°F	
LABEL	REFRIGERANT	OPERATING RANGE																																																
R22	r22	-50-60°C/-58+120°F																																																
134	r134A	-50-60°C/-58+120°F																																																
290	r290 – Propane	-50-60°C/-58+120°F																																																
404	r404A	-70-60°C/-94+120°F																																																
47A	r407A	-50-60°C/-58+120°F																																																
47C	r407C	-50-60°C/-58+120°F																																																
47F	r407F	-50-60°C/-58+120°F																																																
410	r410A	-50-60°C/-58+120°F																																																
448	r448A	-45-60°C/-69+120°F																																																
449	r449A	-45-60°C/-69+120°F																																																
450	r450A	-45-60°C/-69+120°F																																																
507	r507	-70-60°C/-94+120°F																																																
513	r513A	-45-60°C/-69+120°F																																																
CO2	r744 - Co2	-50-60°C/-58+120°F																																																
	FtY	404	Kind of gas.																																															
	Atu	y	Minimum STABLE superheat search	No; yES	This parameter enables the search of the minimum stable superheat. The lowest admitted value is LSH+2°C																																													
	AMS	y	Self self adaptive SH regulation enabling	No; yES	This parameter enables the self adaptive regulation of the superheat. CrE = no must to be set, when this function is enabled.																																													
	SSH	8.0	Superheat set point.	[0.1°C to 25.5°C] [1°F to 45°F]	This is the value used to regulate superheat.																																													
	Pb	8,0	Proportional band.	[0.1°C to 60.0°C] [1°F to 108°F]	The valve changes its opening on the band [SSH, SSH + Pb]. At SSH value of superheat the valve will be at 0% (without integral contribution) and at [SSH + Pb] value of superheat the valve will be at MnF. For values bigger than [SSH + Pb] the valve is completely opened.																																													
	rS	0.0	Proportional band reset	[-12.0°C to 12.0°C]	It allows to move the regulation band, above or below the SH set point.																																													
	inC	200	Integration time for superheat regulation.	0 to 255s	-																																													
	PEO	50	Valve opening in case of error on probes P5 or P6.	0 to 100%	If a temporary probe error occurs, valve opening percentage is PEO until PEd time is elapsed.																																													
	OPE	85	Start opening percentage for the time SFd. It's not limited by the MnF parameter	0 to 100%	Opening valve percentage when start function is active. This phase duration is SFd time.																																													
	SFd	0.1	Duration of soft start phase with opening at OPE.	0.0 to 42min00sec (252)	Set start function duration and post-defrost duration. During this phase the alarms are neglected. Format: min.10sec, resolution: 10sec.																																													
	OPd	85	Valve opening percentage during hot gas defrost. It's not limited by the MnF parameter.	0 to 100%	Opening valve percentage during hot gas defrost. During hot gas defrost there is not SH control.																																													
	MnF	100	Maximum percentage of opening admitted (during normal functioning).	0 to 100%	During regulation it sets the maximum valve opening percentage. This value is not used during the SFd phase (soft start) and during hot gas defrost, where the fixed percentage of the valve opening is set by oPd.																																													
	Fot	nU	Manual opening.	0 to 100% nU	It permits to force the valve opening to the specified value. This value overwrites the one calculated by PID algorithm. !!!! WARNING !!!! It must be [Fot = nU] to have correct superheat regulation.																																													
	PA4	-0.5	Probe value at 4mA or at 0V.	<table border="1"> <thead> <tr> <th>Meas Unit</th> <th>Range</th> </tr> </thead> <tbody> <tr><td>BAR</td><td>[PrU=rE] -1.0 to P20 [PrU=Ab] 0.0 to P20</td></tr> <tr><td>PSI</td><td>[PrU=rE] -14 to P20 [PrU=Ab] 0 to P20</td></tr> <tr><td>dKP</td><td>[PrU=rE] -10 to P20 [PrU=Ab] 0 to P20</td></tr> </tbody> </table>	Meas Unit	Range	BAR	[PrU=rE] -1.0 to P20 [PrU=Ab] 0.0 to P20	PSI	[PrU=rE] -14 to P20 [PrU=Ab] 0 to P20	dKP	[PrU=rE] -10 to P20 [PrU=Ab] 0 to P20	Value of pressure at 4mA for current probe [4 to 20mA] or value at 0V for ratiometric probes. The value is absolute or relative according to PrU parameter.																																					
Meas Unit	Range																																																	
BAR	[PrU=rE] -1.0 to P20 [PrU=Ab] 0.0 to P20																																																	
PSI	[PrU=rE] -14 to P20 [PrU=Ab] 0 to P20																																																	
dKP	[PrU=rE] -10 to P20 [PrU=Ab] 0 to P20																																																	
	P20	11.0	Probe value at 20mA or at 5V.	<table border="1"> <thead> <tr> <th>Meas Unit</th> <th>Range</th> </tr> </thead> <tbody> <tr><td>BAR</td><td>[PrU=rE] PA4 to 60.0 [PrU=Ab] PA4 to 60.0</td></tr> <tr><td>PSI</td><td>[PrU=rE] PA4 to 870 [PrU=Ab] PA4 to 870</td></tr> <tr><td>dKP</td><td>[PrU=rE] PA4 to 600 [PrU=Ab] PA4 to 600</td></tr> </tbody> </table>	Meas Unit	Range	BAR	[PrU=rE] PA4 to 60.0 [PrU=Ab] PA4 to 60.0	PSI	[PrU=rE] PA4 to 870 [PrU=Ab] PA4 to 870	dKP	[PrU=rE] PA4 to 600 [PrU=Ab] PA4 to 600	Value of pressure at 20mA for current probe [4 to 20mA] or value at 5V for ratiometric probes. The value is absolute or relative according to PrU parameter.																																					
Meas Unit	Range																																																	
BAR	[PrU=rE] PA4 to 60.0 [PrU=Ab] PA4 to 60.0																																																	
PSI	[PrU=rE] PA4 to 870 [PrU=Ab] PA4 to 870																																																	
dKP	[PrU=rE] PA4 to 600 [PrU=Ab] PA4 to 600																																																	
	LPL	-0.5	Lower Pressure Limit for superheat regulation.	PA4 to P20	EXPERT: when suction pressure goes down the lower bound LPL, superheat regulation will use a fixed pressure value. Otherwise, the normal pressure value will be used (according to PrU parameter).																																													
	MOP	11.0	Maximum operating pressure threshold and valve closing of dML value.	LOP to P20	If suction pressure exceeds maximum operating pressure value, the instrument will signal this situation giving the MOP alarm (according to PrU parameter).																																													
	LOP	-0.5	Minimum operating pressure threshold and valve opening of dML value.	PA4 to MOP	If suction pressure exceeds minimum operating pressure value, the instrument will signal this situation giving the LOP alarm (according to PrU parameter).																																													
	dML	30	Delta [MOP - LOP].	0 to 100%	Until MOP alarm is active, the valve will close, every second, of a value equal to the dML percentage. Until LOP alarm is active, the valve will open, every second, of a value equal to the dML percentage.																																													
	MSH	60.0	Maximum superheat alarm threshold.	[LSH to 80.0°C] [LSH to 144°F]	If superheat value exceeds MSH value, the display will show the MSH message until delay time SHd will expire.																																													

	LABEL	VALUE	DESCRIPTION	RANGE	NOTES
	LSH	2.0	Minimum superheat alarm threshold.	[0.0°C to MSH] [0°F to MSH]	If the superheat value is lower than LSH during the SHd delay time, then the display will show the message LSH . As soon as the superheat value is lower than LSH value, the valve will close immediately, without waiting the SHd delay time (to avoid evaporator flooding).
	SHY	1.0	Hysteresis for superheat alarm recovery [MSH – SHY] and [LSH + SHY].	[0.1°C to 25.5°C] [1°F to 45°F]	-
	SHd	3.0	Delay of superheat alarm signaling.	0.0 to 42min00sec (252)	If a superheat alarm occurs, the delay time SHd will have to expire before the controller shows an alarm. Format: min.10sec, resolution: 10sec.
	FrC	0	Integration additive constant (Fast-recovery).	0 to 100s	It permits to decrease faster the integral action when SH value is below the set-point. With higher values the valve closes faster. If [FrC = 0] fast recovery function is disabled.
	Sub	10	Number of pressure values used to calculate the average pressure	0+100	It uses the last average values of the pressure to calculate the superheat.
	SLb	0.0	Reaction time	0+255s	0 = controller calculates automatically the time to update the valve position. 1+255s = controller updates valve position every SLb seconds
	tEP	nu	Predefined valve selection.	nU to 10	See par. 6.3. nU = manual setting.
	tEU	bP	Kind of valve.	uP; bP	uP = unipolar valve (5-6 wires); bP = bipolar valve (4 wires).
	HSF	FUL	Kind of motor movement	HAF; FUL	HAF = half step. Use this setting for the unipolar valve. FUL = half step. Use this setting for the bipolar valve.
	LSt	0	Minimum number of steps where the valve can be considered as completely closed.	0 to USt (* 10)	For manual adjusting of the valve.
	USt	0	Maximum number of steps that can be performed.	LSt to 800 (* 10)	For manual adjusting of the valve.
	Est	0	Extra steps in closing phase	0 to 255(*10)	Extra steps done by the valve during closing phase to assure the valve closes completely
	Sr	10	Step rate: is the speed to change step. A too high value causes a wrong driving.	10 to 600 (steps/sec)	For manual adjusting of the valve.
	CPP	0	Current per phase during bipolar valve driving.	0 to 100 (* 10mA)	For manual adjusting of the valve.
	CHd	0	Current per phase to maintain the actual position (Holding current).	0 to 100 (* 10mA)	For manual adjusting of the valve.
	GtH	0.0	Autozero function	0+15h	To prevent any possible wrong position caused by a long period without closing the valve, the controller after gtH hours, as soon as the opening open percentage is under 20%, will force complete closer of the valve, and then will restart working.
REGULATION					
	SET	-5.0	Set point	LS+US	Target set point for temperature regulation
	HY	2	Differential.	[0.1°C to 25.5°C] [1°F to 45°F]	If [CrE = n] then HY is the hysteresis for ON/OFF thermoregulation. If [CrE = Y] or [CrE = EUP] then HY is the proportional band for temperature PI controller. On these cases the value should be greater than 5°C.
	int	150	Integral time for room temperature regulation.	0 to 255s	This value is used only when [CrE = Y] or [CrE = EUP]. It's the integral time for thermoregulation: high values mean slower regulation. 0 (zero) = no integral action.
	CrE	n	Continuous regulation activation.	n(0); Y(1); EUP(2)	With [CrE = Y] or [CrE = EUP] the regulation become PI , HY become a band and int an integral time. n = standard regulation; Y = continuous regulation, to be used only in centralized plants; EUP = evaporator valves (see par. 16.2).
	LS	-30.0	Minimum set point.	[-55.0°C to SET] [-67°F to SET]	Set the minimum acceptable value for the set-point.
	US	20.0	Maximum set point.	[SET to 150.0°C] [SET to 302°F]	Set the maximum acceptable value for the set-point.
	odS	0	Outputs activation delay at start up.	0 to 255min	This function is enabled at the initial start up of the instrument and inhibits any output activation for the period of time set in this parameter (N.B.: AUX and Light can work).
	AC	0	Anti-short cycle delay.	0 to 60min	Interval between the solenoid valve stop and the following restart.
	CCt	0.0	Continuous cycle duration.	0.0 to 24h00min (144)	Compressor ON time during continuous cycle: allows to set the length of the continuous cycle: compressor stays on without interruption for the CCt time. It can be used, for instance, when the room is filled with new products. Format: hours.10min, resolution: 10min.
	CCS	0.0	Continuous cycle set point.	[-55.0°C to 150.0°C] [-67°F to 302°F]	Set point for continuous cycle: used value during the continuous cycle.
	Con	15	Compressor ON time with faulty probe.	0 to 255min	Solenoid valve ON time with faulty probe: time during which the solenoid valve is active in case of faulty thermostat probe. With CO_n = 0 solenoid valve is always OFF.
	CoF	30	Compressor OFF time with faulty probe.	0 to 255min	Solenoid valve OFF time with faulty probe: time during which the solenoid valve is off in case of faulty thermostat probe. With COF = 0 solenoid valve is always active.
	CF	°C	Temperature measurement unit.	°C(0); °F(1)	°C = Celsius; °F = Fahrenheit. !!! WARNING !!! When the measurement unit changes, all parameters with temperature values will have to be checked.
	PrU	rE	Pressure Mode.	rE(0); Ab(1)	It defines the mode to evaluate the pressure values. !!! WARNING !!! PrU value is used for all the pressure parameters. If [PrU = rE] all pressure parameters are in relative pressure unit, if [PrU = Ab] all pressure parameters are in absolute pressure unit.

	LABEL	VALUE	DESCRIPTION	RANGE	NOTES
	PMU	Bar	Pressure measurement unit.	bAr(0); PSI(1); MPA(2)	It selects the pressure measurement units. MPA means the value of pressure measured by kPA*10.
	PMd	PrE	Pressure probe visualization	tEM, PrE	It selects the visualization of pressure probe (P5): tEM = temperature; PrE = pressure
	rES	dE	Resolution (only °C).	dE; in	It sets decimal point display. in = 1°C; dE = 0.1 °C.
	Lod	tEr	Local display: default display.	nP(0); P1(1); P2(2); P3(3); P4(4); P5(5); P6(6); tEr(7); dEF(8)	It selects which probe is displayed by the instrument. nP = no probe; P1, P2, P3, P4, P5, P6, tEr = virtual probe for thermostat; dEF = virtual probe for defrost.
	rEd	tEr	Remote display: default display.	nP(0); P1(1); P2(2); P3(3); P4(4); P5(5); P6(6); tEr(7); dEF(8)	It selects which probe is displayed by the X-REP. nP = no probe; P1, P2, P3, P4, P5, P6, tEr = virtual probe for thermostat; dEF = virtual probe for defrost.
	dLY	0.0	Display delay.	0.0 to 24h00min (144)	When the temperature changes, the display will be updated of 1°C / 1°F when delay time expires. Format: min.10sec, resolution: 10sec.
	rPA	P1	Regulation probe A.	nP(0); P1(1); P2(2); P3(3); P4(4); P6(5)	First probe used to regulate room temperature. If [rPA = nP] the regulation is performed with real value of rPb .
	rPb	nP	Regulation probe B.	nP(0); P1(1); P2(2); P3(3); P4(4); P6(5)	Second probe used to regulate room temperature. If [rPb = nP] the regulation is performed with real value of rPA .
	rPE	100	Virtual probe percentage (room temperature).	0 to 100%	It defines the percentage of the rPA respect to rPb . The value used to regulate room temperature is obtained by: value_for_room = (rPA*rPE + rPb*(100-rPE))/100
			DEFROST		
	dPA	P2	Defrost probe A.	nP(0); P1(1); P2(2); P3(3); P4(4); P6(5)	First probe used for defrost. If [dPA = nP] the regulation is performed by time
	dPb	nP	Defrost probe B	nP(0) - P1(1) - P2(2) - P3(3) - P4(4) - P5(5)	Second probe used for defrost. If [dPb = nP] the regulation is performed with dPA.
	dPE	100	Percentuale sbrinamento	0 ÷ 100 (100=dPA, 0=dPb)	It defines the percentage of the dPA respect to dPb. The value used to regulate room temperature is obtained by: value_for_defrost=(dPA*dPE + dPb*(100-dPE))/100
	tdF	EL	Defrost kind.	EL; in	EL = defrost with electrical heater; in = hot gas defrost. NOTE: The valve opening percentage during the defrost is set by the par. oPd.
	EdF	in	Defrost mode.	rtC; in	rtC = defrost activation via RTC with Ld1, Ld2 ... parameters; in = defrost activation with idf parameter.
	dtE	8.0	End defrost temperature on probe A (dPA).	[-55.0°C to 50.0°C] [-67°F to 122°F]	Set the temperature measured by the evaporator probe dPA which stops the defrost. N.B.: parameter enabled only when the evaporator probe is present.
	idf	6	Defrost interval.	0 to 120hours	It sets the time interval between the beginning of two defrost cycles. [EdF = in]: it is the interval between 2 defrost; [EdF = rtC]: it is the safety interval in case of clock alarm [rtC – rtF]. [idf = 0]: the defrost can be activated only manually, or through RS485 or from external contact or from LAN.
	MdF	45	(Maximum) duration for defrost.	0 to 255min	When dPA in not present, it sets the defrost duration, otherwise it sets the maximum duration for defrost.
	dSd	0	Defrost start delay after request.	0 to 255min	Useful when different defrost start times are necessary to avoid overloading the plant.
	dFd	it	Display during defrost.	rt; it; SEt; dEF	rt = real temperature for Lod probe; it = initial temperature (reading when defrost start); SEt = set-point value; dEF = "dEF" label is visualized.
	dAd	30	Display delay.	0 to 255min	Set the maximum time between the end of defrost and the restarting of the real room temperature display.
	Fdt	1	Drain down time after defrost.	0 to 255min	Time interval between reaching defrost termination temperature and the restoring of the control's normal operation. This time allows the evaporator to eliminate water drops that might have formed due to defrost. <u>The fan and the thermoregulation output are OFF during this time.</u>
	dPo	n	Defrost at power-on.	n; Y	First defrost after start-up: Y = Immediately; n = after the idf time.
	dAF	0.0	Defrost delay after continuous cycle.	0.0 to 24h00min (144)	Time interval between the end of the fast freezing cycle and the following defrost related to it. Format: hours.10min, resolution: 10min.
			FAN		
	FPA	P2	Fan probe A	nP(0); P1(1); P2(2); P3(3); P4(4); P6(5)	First probe used for fan. If [FPA = nP] the regulation is performed with real value of FPb .
	FnC	O-n	Fan operating mode.	C-n; C-Y; O-n; O-Y	C-n = running with the solenoid valve, OFF during the defrost; C-Y = running with the solenoid valve, ON during the defrost; O-n = continuous mode, OFF during the defrost; O-Y = continuous mode, ON during the defrost.
	Fnd	10	Fan delay after defrost.	0 to 255min	The time interval between the ending of the defrost and the starting of the evaporator fans.
	FCt	10	Temperature differential to avoid short cycles of fans.	[0.0°C to 50.0°C] [0°F to 90°F]	If the difference of temperature between the evaporator and the room probes is more than the value of the FCt parameter, the fans will start.
	FSt	2.0	Fan stop temperature.	[-55.0°C to 50.0°C] [-67°F to 122°F]	Evaporator probe temperature above which the fan is always OFF.
	FHY	1.0	Fan stop differential	[0.1°C to 25.5°C] [1°F to 45°F]	When stopped, fan restarts when fan probe reaches [FSt – FHY] value of temperature.
	tFE	n	Fan thermostat also during defrost	n; Y	n = fan follows FnC setting during defrost without temperature control y = fan follows FnC setting during defrost with FSt temperature control

	LABEL	VALUE	DESCRIPTION	RANGE	NOTES
	Fod	0	Fan activation time after defrost (without compressor)	0 to 255min	It forces fan activation for the indicated time.
	Fon	0	Fan ON time	0 to 15min	With [FnC = C-n or C-Y] (fan activated in parallel with compressor), it sets the evaporator fan ON cycling time when the compressor is off. With [Fon = 0] and [FoF ≠ 0] the fan is always off, with [Fon = 0] and [FoF = 0] the fan is always off.
	FoF	0	Fan OFF time	0 to 15min	With [FnC = C-n or C-Y] (fan activated in parallel with compressor) it sets the evaporator fan off cycling time when the compressor is off. With [Fon = 0] and [FoF ≠ 0] the fan are always off, with [Fon = 0] and [FoF = 0] the fan are always off.
	trA	UAL	Kind of PWM regulation	UAL; rEG; AC	PWM output if CoM value is different from OA7 . UAL = the output is at FSA value (manual value); rEG = the output is regulated with fan algorithm described in fan section; AC = anti-sweat heaters control (require XWEB5000 system).
	SOA	0	Manual value of the analog output	AMi to AMA	Value for the output if [trA = UAL] (0 to 100%).
	SdP	30.0	Default Dew-Point value (or safety value in case of XWEB link lost)	[-55.0°C to 50.0°C] [-67°F to 122°F]	Default value of dew-point used when there is no supervising system (XWEB5000). Used only if [trA = AC] .
	ASr	1.0	Differential for fan / offset for anti sweat heater.	[-25.5°C to 25.5°C] [-45°F to 45°F]	trA = AC : dew-point offset; trA = rEG : differential for modulating fan regulation.
	PbA	5.0	Proportional band for modulating output.	[0.1°C to 25.5°C] [1°F to 45°F]	Differential for anti-sweat heaters.
	AMi	0	Minimum output for modulating output.	0 to AMA	Minimum value for analog output: (0 to AMA).
	AMA	100	Maximum output for modulating output.	AMi to 100	Maximum value for analog output: (AMi to 100).
	AMt	5	Time with fan at maximum speed or ON time for relay on Anti-sweat regulation.	[10 to 60s] or [10 to 60min]	trA = AC : Anti-sweat heaters cycle period; trA = rEG : Time with fan at maximum speed. During this time the fan works at maximum speed. If intended for fan, the basetime is on seconds, for anti-sweat regulation the basetime is on minutes.
ALARM					
	rAL	tEr	Probe for room temperature alarm.	nP; P1; P2; P3; P4; P6; tEr	It selects the probe used to signal alarm temperature.
	ALC	rE	Room temperature alarm configuration: relative to set point or absolute.	rE; Ab	rE = High and Low alarms related to set-point; Ab = High and low alarms related to the absolute temperature.
	ALU	15.0	High room temperature alarm setting.	[0.0°C to 50.0°C] or [ALL to 150.0°]	ALC = rE : [0.0°C to □50.0°C] or [32°F to 90°F]; ALC = Ab : [ALL to 150°C] or [ALL to 302°F]. When this temperature is reached and after the ALd delay time is expired, the HA alarm will be enabled.
	ALL	15.0	Low room temperature alarm setting.	[0.0°C to 50.0°C] or [-55.0°C to ALU]	ALC = rE : [0.0°C to □50.0°C] or [32°F to 90°F]; ALC = Ab : [-55.0°C to ALU] or [-67°F to ALU]. After this temperature is reached and the ALd delay time is expired, the LA alarm will be enabled.
	AHY	1.0	Differential for room temperature alarm.	[0.1°C to 25.5°C] [1°F to 45°F]	Threshold recovery after a temperature alarm.
	ALd	15	Room Temperature alarm delay.	0 to 255min	Time interval between the detection of an alarm condition and the corresponding alarm signaling.
	dLU	150	High temperature alarm detected by defrost probe	[dLL ÷ 150.0°] [dLL ÷ 302°F]	When this temperature is reached and after the ddL delay time is expired, the HAd alarm will be enabled.
	dLL	-50.0	Low room alarm detected by defrost probe.	[-55,0°C ÷ dLU] [-67°F ÷ dLU°F]	When this temperature is reached and the ddL delay time is expired, the LAd alarm will be enabled.
	dHY	1.0	Differential for temperature alarm detected by defrost probe.	[0.1°C ÷ 25.5°C] [1°F ÷ 45°F]	Threshold recovery after a temperature alarm.
	ddA	15	Delay of temperature alarm detected by defrost probe.	0 ÷ 255 (min.)	Time interval between the detection of an alarm condition and the corresponding alarm signaling.
	FLU	150	High temperature alarm detected by fan probe	[FLL ÷ 150.0°] [FLL ÷ 302°F]	When this temperature is reached and after the FAd delay time is expired, the HAF alarm will be enabled.
	FLL	-50.0	Low room alarm detected by fan probe.	[-55,0°C ÷ FLU] [-67°F ÷ FLU°F]	When this temperature is reached and the FAd delay time is expired, the FAd alarm will be enabled.
	FHY	1.0	Differential for temperature alarm detected by fan probe.	[0.1°C ÷ 25.5°C] [1°F ÷ 45°F]	Threshold recovery after a temperature alarm.
	FAd	15	Delay of temperature alarm detected by fan probe.	0 ÷ 255 (min.)	Time interval between the detection of an alarm condition and the corresponding alarm signaling.
	dAo	1.3	Delay of temperature alarm at start-up.	0.0 to 24h00min	After powering on the instrument: time interval between the detection of the temperature alarm condition and the alarm signaling. Format : hours.10min, resolution : 10min.
	EdA	20	Alarm delay at the end of defrost.	0 to 255min	At the end of the defrost cycle: time interval between the detection of the temperature alarm condition and the alarm signaling.
	dot	20	Temperature alarm exclusion after door open.	0 to 255min	-
	Sti	nU	Stop regulation interval.	0.0 to 24h00min; nU	After regulating continuously for Sti time, the valve closes for Std time in order to prevent ice creation. Format : hours.10min, resolution : 10min.
	Std	5	Stop duration.	1 to 255min	It defines stop regulation time after Sti .
	nMS	nU	Maximum number of regulation pauses.	"nu"(0) ÷ 255	-
	tbA	y	Silencing alarm relay by pressing a key.	n; Y	-
OUTPUT CONFIGURATION:					
	OA1	CPr	Relay on terminals 11-12 configuration	nU; CPr; dEF; FAn; ALr; LiG; AUS; db; onF; AC	nU = not used; CPr = compressor / valve; dEF = defrost; FAn = Fan; ALr = Alarm; LiG = Light; AUS = auxiliary; db = heater for neutral zone (not available with CrE = Y); onF = ON/OFF; AC = anti-sweet.; E3r: Not set
	OA6	AUS	Relay on terminals 17-18 configuration	nU; CPr; dEF; FAn; ALr; LiG; AUS; db; onF; AC	nU = not used; CPr = compressor / valve; dEF = defrost; FAn = Fan; ALr = Alarm; LiG = Light; AUS = auxiliary; db = heater for neutral zone (not available with CrE = Y); onF = ON/OFF; AC = anti-sweet.; E3r: Not set

	LABEL	VALUE	DESCRIPTION	RANGE	NOTES
	CoM	Cur	Modulating output configuration.	PM5; PM6; OA7; CUr; tEn	For models with PWM / O.C. output: - PM5 = PWM 50Hz; - PM6 = PWM 60Hz; - OA7 = two state, it can be used as an open collector output. For models with [4 to 20mA] or [0 to 10V] output: - CUr = 4 to 20mA current output; - tEn = 0 to 10V voltage output.
	AOP	CL	Alarm relay polarity.	OP; CL	CL = normally closed; OP = normally opened.
	iAU	n	Auxiliary output independent from ON/OFF state.	n; Y	n = if the instrument is switched off also the auxiliary output is switched off; Y = the auxiliary output state is unrelated to the ON/OFF device status.
DIGITAL INPUTS					
	i1P	CL	Digital input 1 polarity.	OP; CL	CL = the digital input is activated by closing the contact; OP = the digital input is activated by opening the contact.
	i1F	dor	Digital input 1 configuration.	EAL; bAL; PAL; dor; dEF; AUS; LiG; OnF; Htr; FHU; ES; HdY	EAL = external alarm; bAL = serious external alarm; PAL = pressure switch activation; dor = door open; dEF = defrost activation; AUS = auxiliary activation; LiG = light activation; OnF = switch on/off the instrument; Htr = change type of action; FHU = not used; ES = activate energy saving; HdY = activate holiday function.
	d1d	15	Digital input 1 activation delay.	0 to 255min	When [i1F = PAL]: time interval to calculate the number of the pressure switch activation. When [i1F = EAL or bAL] (external alarms): d1d parameter defines the time delay between the detection and the successive signaling of the alarm. When [i1F = dor]: this is the delay to activate door open alarm.
	i2P	CL	Digital input 2 polarity.	OP; CL	CL means the digital input is activated by closing the contact; OP means the digital input is activated by opening the contact.
	i2F	LiG	Digital input 2 configuration.	EAL; bAL; PAL; dor; dEF; AUS; LiG; OnF; Htr; FHU; ES; HdY	EAL = external alarm; bAL = serious external alarm; PAL = pressure switch activation; dor = door open; dEF = defrost activation; AUS = auxiliary activation; LiG = light activation; OnF = switch on/off the instrument; Htr = change type of action; FHU = not used; ES = activate energy saving; HdY = activate holiday function.
	d2d	5	Digital input 2 activation delay.	0 to 255min	When [i2F = PAL]: time interval to calculate the number of the pressure switch activation. When [i2F = EAL or bAL] (external alarms): d2d parameter defines the time delay between the detection and the successive signaling of the alarm. When [i2F = dor]: this is the delay to activate door open alarm.
	i3P	CL	Digital input 3 polarity.	OP; CL	CL means the digital input is activated by closing the contact; OP means the digital input is activated by opening the contact.
	i3F	ES	Digital input 3 configuration.	EAL; bAL; PAL; dor; dEF; AUS; LiG; OnF; Htr; FHU; ES; HdY	EAL = external alarm; bAL = serious external alarm; PAL = pressure switch activation; dor = door open; dEF = defrost activation; AUS = auxiliary activation; LiG = light activation; OnF = switch on/off the instrument; Htr = change type of action; FHU = not used; ES = activate energy saving; HdY = activate holiday function.
	d3d	0	Digital input 3 activation delay.	0 to 255min	When [i3F = PAL]: time interval to calculate the number of the pressure switch activation. When [i3F = EAL or bAL] (external alarms): d3d parameter defines the time delay between the detection and the successive signaling of the alarm. When [i3F = dor]: this is the delay to activate door open alarm.
	nPS	15	Number of pressure switch activations before lock.	0 to 15	Number of activation of the pressure switch, during the d1d, d2d and d3d interval, before signaling the alarm event [i1F, i2F or i3F = PAL]. <u>If the nPS activation in the d1d, d2d or d3d time is reached, switch off and on the instrument to restart normal regulation.</u>
	OdC	F-C	Compressor and fan status when open door.	no; FAn; CPr; F-C	no = normal; FAn = Fan OFF; CPr = Compressor OFF; F_C = both Compressor and Fan OFF.
	rrd	15	Output restart delay with door open.	0 to 255min	The outputs stopped by the OdC parameter can restart after rrd time.
ENERGY SAVING					
	ESP	P1	Energy saving probe selection.	nP; P1; P2; P3; P4; P6; tEr	-
	HES	0.0	Temperature increasing during Energy Saving.	[-30.0°C to 30.0°C] [-54°F to 54°F]	Sets the increasing value of the set point during the Energy Saving cycle.
	PEL	nU	Energy saving activation when Light or/and AUX are switched off.	nU(0); LiG(1); AUS(2); LEA(3)	Energy saving enabled when: - LiG: light switched off; - AUS: AUX switched off; - LEA: both light and AUX switched off. If nU then not used function.
LAN MANAGEMENT					
	LMd	y	Defrost Synchronization.	n; Y	n = the section doesn't send a global defrost command; Y = the section sends a command to start defrost to other controllers.
	dEM	y	Defrost end Synchronization.	n; Y	n = the end of the LAN defrosts are independent; Y = the end of the LAN defrosts are synchronized.
	LSP	n	LAN set-point Synchronization.	n; Y	n = the set-point value is modified only in the local section; Y = the section set-point, when modified, is updated to the same value on all the other sections.
	LdS	n	LAN Display Synchronization (temperature sent via LAN).	n; Y	n = the set-point value is modified only in the local section; Y = the value displayed by the section is sent to all the other sections.

	LABEL	VALUE	DESCRIPTION	RANGE	NOTES
	LOF	n	LAN ON/OFF Synchronization.	n; Y	This parameter states if the On/Off command of the section will act on all the other ones too: n = the On/Off command acts only in the local section; Y = the On/Off command is sent to all the other sections.
	LLi	y	LAN Light Synchronization.	n; Y	This parameter states if the light command of the section will act on all the other ones too: n = the light command acts only in the local section; Y = the light command is sent to all the other sections.
	LAU	n	AUX Synchronization.	n; Y	This parameter states if the AUX command of the section will act on all the other ones too: n = the light command acts only in the local section; Y = the light command is sent to all the other sections.
	LES	n	Energy Saving Synchronization.	n; Y	This parameter states if the energy saving command of the section will act on all the other ones too: n = the Energy Saving command acts only in the local section; Y = the Energy Saving command is sent to all the other sections.
	LSd	n	Remote probe displaying.	n; Y	This parameter states if the section has to display the local probe value or the value coming from another section: n = the displayed value is the local probe one; Y = the displayed value is the one coming from another section (which has parameter LdS = Y).
	LPP	y	Pressure probe through the LAN.	n; Y	n = the value of pressure probe is read from local probe; Y = the value of pressure probe is sent via LAN.
	LCP	n	Probe 4 through the LAN.	n; Y	
	StM	n	Cooling request from LAN enable compressor relay.	n; Y	n = not used; Y = a generic cooling requests from LAN activate the solenoid valve connected to compressor relay.
	ACE	n	Cooling request from LAN enable even if compressor is stopped by door switch	n; Y	n = not used; Y = a generic cooling requests from LAN activate the solenoid valve connected to compressor relay.
			PROBE CONFIGURATION NTC (10KΩ a 25°C), PtC (806Ω a 0°C)		
	P1C	ntC	P1 configuration.	nP; PtC; ntC; CtC; PtM	nP = not present; PtC = Ptc; ntC = ntc; CtC = ntc US PtM = Pt1000.
	Ot	0	P1 calibration.	[-12.0°C to 12.0°C]	Allows to adjust possible offset of the thermostat probe.
	P2C	ntC	P2 configuration.	nP; PtC; ntC; CtC; PtM	nP = not present; PtC = Ptc; ntC = ntc; CtC = ntc US PtM = Pt1000.
	oE	0	P2 calibration.	[-12.0°C to 12.0°C]	Allows to adjust possible offset of the evaporator probe.
	P3C	nP	P3 configuration.	nP; PtC; ntC; CtC; PtM	nP = not present; PtC = Ptc; ntC = ntc; CtC = ntc US PtM = Pt1000.
	O3	0	P3 calibration.	[-12.0°C to 12.0°C]	Allows to adjust possible offset of the probe 3.
	P4C	nP	P4 configuration.	nP; PtC; ntC; CtC; PtM; LAN	nP = not present; PtC = Ptc; ntC = ntc; CtC = ntc US PtM = Pt1000; LAN = value received from master.
	O4	0	P4 calibration.	[-12.0°C to 12.0°C]	Allows to adjust possible offset of the probe 4.
	P5C	420	P5 configuration.	nP; PtC; ntC; CtC; PtM; 420; 5Vr; LAN	nP = not present; PtC = Ptc; ntC = ntc; CtC = ntc US; PtM = Pt1000; 420 = 4 to 20mA; 5Vr = 0 to 5V ratiometric; LAN = value received from master.
	o5	0	P5 calibration.	[-12.0°C to 12.0°C]	Allows to adjust possible offset of the probe 5.
	P6C	PtM	P6 configuration.	nP; PtC; ntC; CtC; PtM	nP = not present; PtC = Ptc; ntC = ntc; CtC = ntc US PtM = Pt1000.
	o6	0	P6 calibration.	[-12.0°C to 12.0°C]	Allows to adjust possible offset of the probe 6.
			SERVICE		
	CLt	- - -	ON/OFF percentage (C.R.O.).	(read only)	It shows the effective cooling time calculated by XM600 during regulation (cooling time percentage).
	tMd	- - -	Time remaining before next defrost activation (only for interval defrost).	(read only)	It shows time before the next defrost when interval defrost is selected.
	LSn	Auto	Number of devices in LAN.	1 to 8 (read only)	Shows the number of sections available in the LAN.
	LAn	Auto	List of address of LAN devices.	1 to 247 (read only)	Identifies the instrument address (1 to LSn) inside local network of multiplexed cabinet controller.
	Adr	1	ModBUS address.	1 to 247	Identifies the instrument address when connected to a ModBUS compatible monitoring system.
	rEL	2.8	Firmware release.	(read only)	Microprocessor firmware release.
	Ptb	- - -	Parameter table.	(read only)	It shows the original code of the Dixell parameter map.
	Pr2	- - -	Pr2 menu access.	(read only)	Access to the protected parameter list.

Dixell S.r.l. - Z.I. Via dell'Industria, 27 - 32010 Alpagò (BL) ITALY
Tel. +39.0437.9833 r.a. - Fax +39.0437.989313 - EmersonClimate.com/Dixell - dixell@emerson.com