

UP-SE6021GS-EAE00

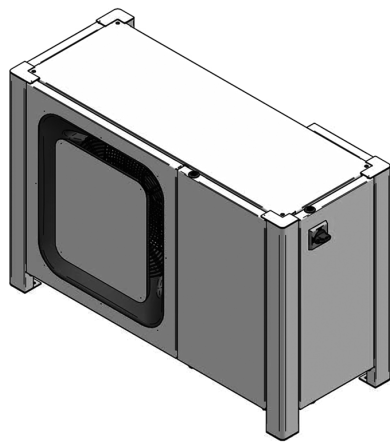

ENGINEERING CODE
6S1COS6C3FI



REFRIGERANT
R-134a



POWER SUPPLY
380-420 V 50 Hz
/ 460 V 60 Hz



APPLICATION
HBP



MOTOR TYPE
3PH



STANDARD
EN13215_RG20

CE

✓ ECODSIGN
COMPLIANT



COOLING CAPACITY
3022 W



EFFICIENCY
2.17 W/W

DATA

GENERAL DATA

Model UP-SE6021GS-EAE00

ELECTRICAL DATA

Rated Load Amperage (RLA) 6.95 A

Maximum Overcurrent Protection (MOP) 15.64 A

Minimum Current Ampacity (MCA) 8.7 A

ACCESSORIES

Dryer	Castel	DF308-M12S
Dualpressostat	KP17W. (060-1275)	1996778
Fanspeed Controller	DANFOSS	XGE-4C. (061H3140)
Heater	70W-230V	2464355
Sightglass	Castel	3940_M12
Discharge valve	FSV44	1996807
Suction valve	FSV66	1996809

CONDENSING COMPONENTS

Compressor	SE6021GS	MBP
Refrigerant	R-404A	
Fan Blade Diameter	400 mm	
Fankit	FAN ASSEMBLY HOUSING 2	1996784

MECHANICAL DATA

Air Flow	2545 m ³ /h
Height	708 mm
Receiver	3.9 L
Shaft Power	120 W
Weight	90 Kg
Width	1082 mm
Length	490 mm

PERFORMANCE

TESTED CONDITIONS

Tested Refrigerant	R-134a
Tested Application	HBP
Tested Standard	EN13215_RG20

RATED POINTS

Ambient Temperature °C	Evaporating Temperature °C	Cooling Capacity W	Efficiency W/W	Consumo de Potencia W
32	-10	3022	2.17	1392

Test Condition: Subcooling 3 K, Return Gas 20 °C.

PERFORMANCE CURVE

Ambient Temperature 25°C

Evaporating Temperature °C	Cooling Capacity W	Efficiency W/W	Consumo de Potencia W
-15	2618	2.18	1202
-5	4001	2.93	1366
0	4854	3.33	1459
5	5801	3.73	1556
10	6829	4.13	1654

Test Condition: Subcooling 3 K, Return Gas 20 °C.

PERFORMANCE CURVE

Ambient Temperature 32°C

Evaporating Temperature °C	Cooling Capacity W	Efficiency W/W	Consumo de Potencia W
-15	2421	1.86	1304
-5	3732	2.50	1491
0	4540	2.84	1596
5	5435	3.19	1706
10	6404	3.52	1817

Test Condition: Subcooling 3 K, Return Gas 20 °C.

PERFORMANCE CURVE

Ambient Temperature 43°C

Evaporating Temperature °C	Cooling Capacity W	Efficiency W/W	Consumo de Potencia W
-15	2106	1.42	1486
-5	3272	1.91	1709
0	3994	2.18	1834
5	4792	2.44	1963

Test Condition: Subcooling 3 K, Return Gas 20 °C.

ENVELOPE

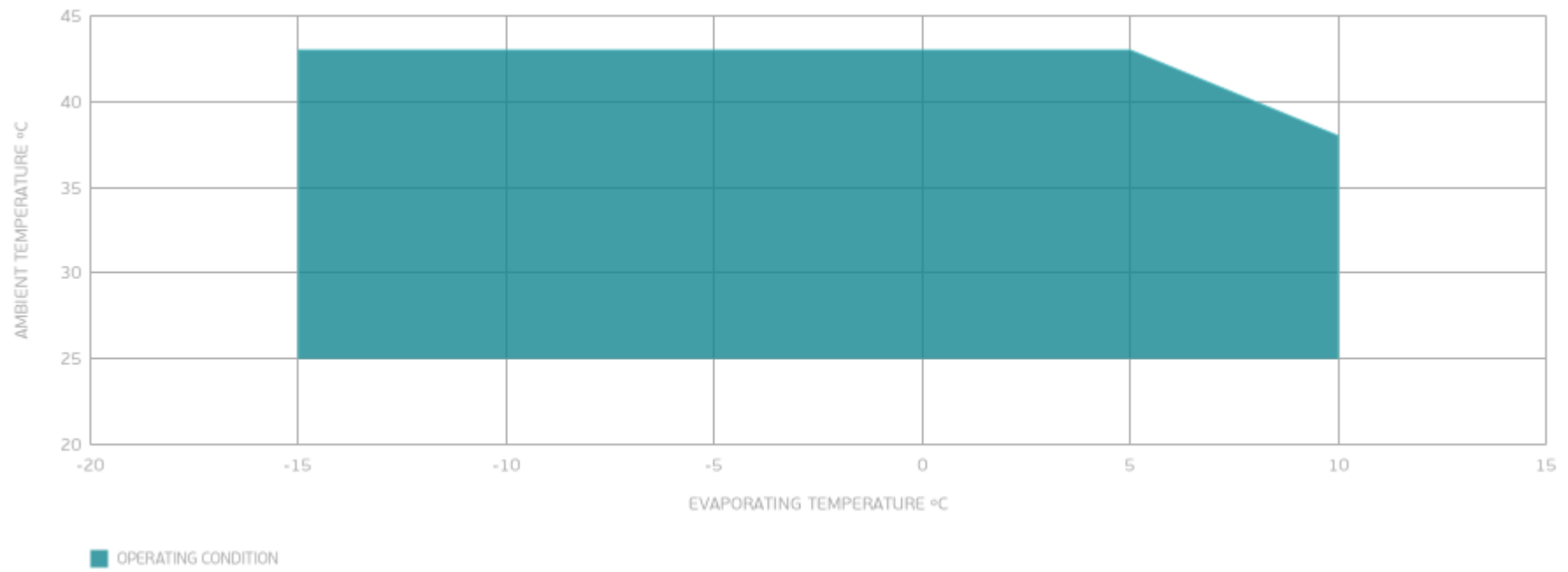

EXTERNAL DIMENSIONS

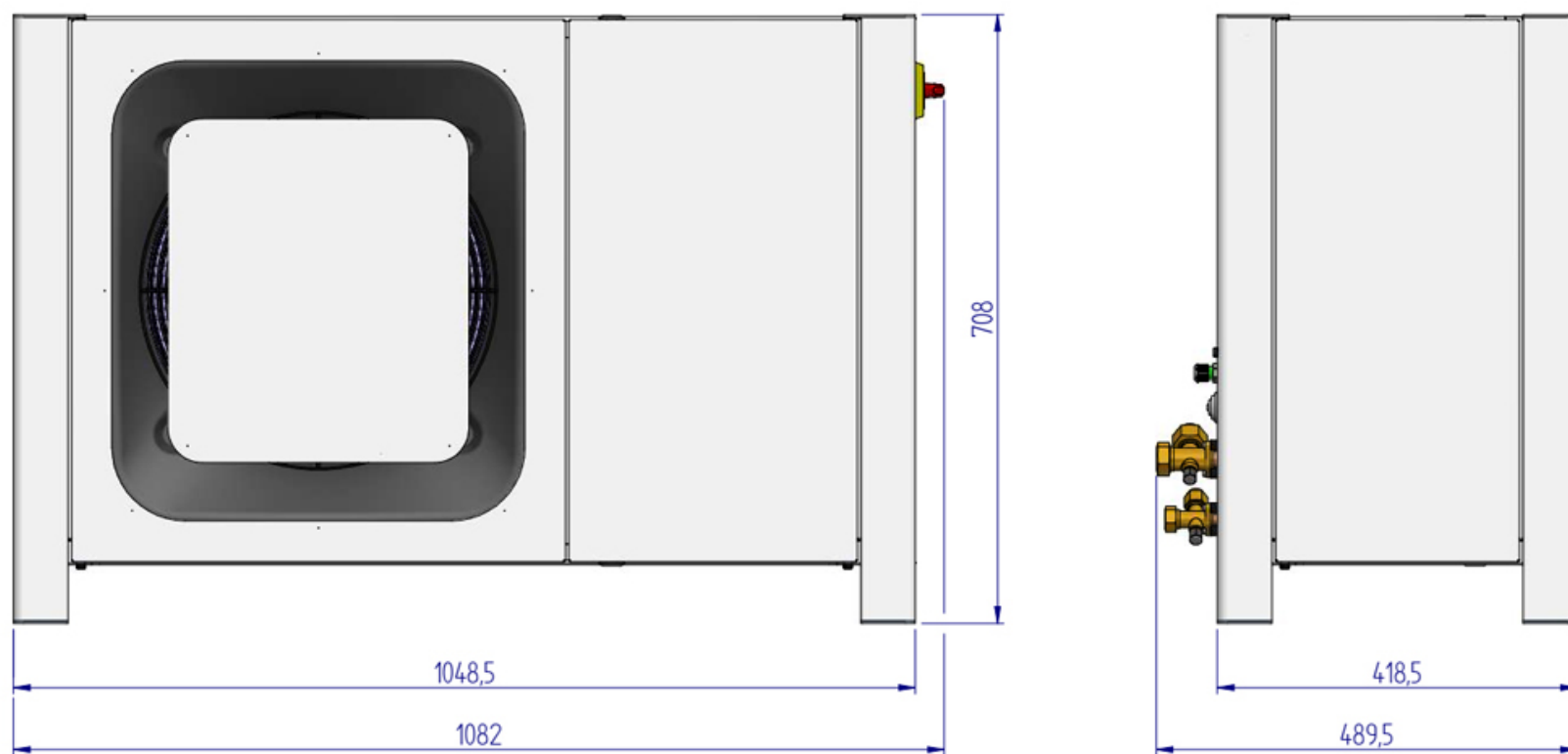

WIRING DIAGRAM

